

OMNI 800
electronic data terminals

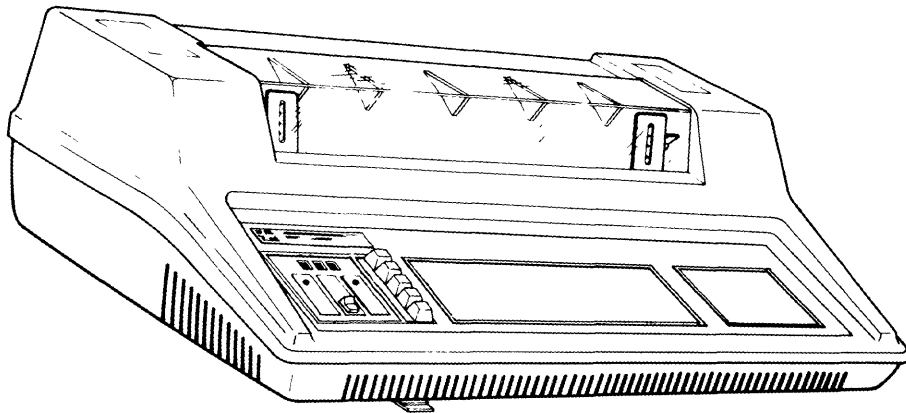

MAINTENANCE MANUAL



**Model 820 RO
Terminal**

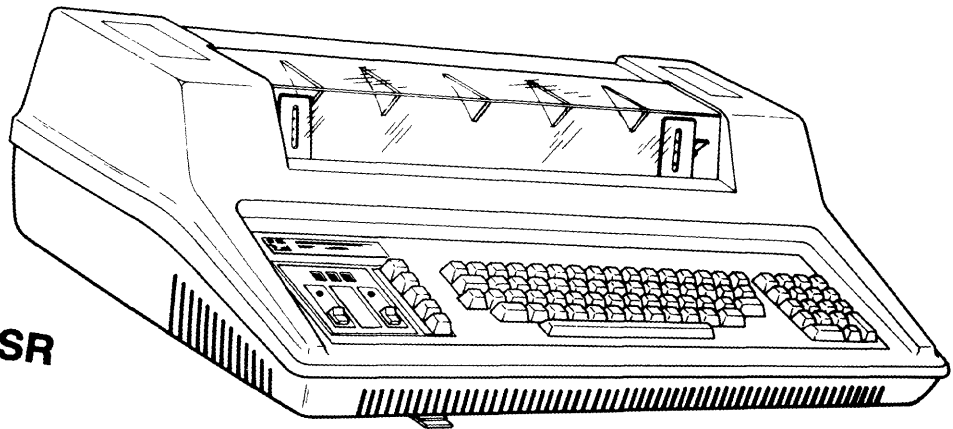

**Model 820 KSR
Terminal**

Manual No. 2206552-9701
15 November 1979

TEXAS INSTRUMENTS
INCORPORATED

The information and/or drawings set forth in this document and all rights in and to inventions disclosed herein and patents which might be granted thereon disclosing or employing the materials, methods, techniques or apparatus described herein are the exclusive property of Texas Instruments Incorporated.

No copies of the information or drawings shall be made without the prior consent of Texas Instruments Incorporated.

INSERT LATEST CHANGED PAGES DESTROY SUPERSEDED PAGES

LIST OF EFFECTIVE PAGES

Note The portion of the text affected by the changes is indicated by a vertical bar in the outer margins of the page

820 KSR/RO Terminals Maintenance Manual
Manual No. 2206552
Original Issue: 15 November 1979

Total number of pages in this publication is **391** consisting of the following

Page No.	Change No.	Page No.	Change No.	Page No.	Change No.
Cover/List of Effective Pages	0	A-1 — A-9	0		
User's Response	0	B-1 — B-7	0		
iii-x	0	C-1 — C-2	0		
1-1 — 1-4	0	D-1	0		
2-1 — 2-21	0	E-1 — E-23	0		
3-1 — 3-26	0	F-1 — F-3	0		
4-1 — 4-24	0	G-1 — G-7	0		
5-1 — 5-23	0	Index 1-3	0		
6-1 — 6-190	0				
7-1 — 7-22	0				

CHANGE NOTICES

Revision Letter	Date	ECN		Description
		Number	Level	

PREFACE

This manual provides detailed information for installing, operating, maintaining and replacing assemblies and subassemblies of the Texas Instruments *Omni 800** Model 820 keyboard send receive (KSR) and receive only (RO) data terminals. The information is divided into the following sections:

- SECTION I **General Description:** This section contains a list of terminal specifications and features, locates the major terminal components, and identifies the various terminal versions and options.
- SECTION II **Installation:** This section provides instructions for selecting a suitable site for the terminal, installing the supplies, making cable connections, applying power, performing terminal checkout, and configuring the terminal.
- SECTION III **Operation:** This section provides a complete functional description of the terminal including the use of controls and indicators.
- SECTION IV **Theory of Operation:** This section identifies the functional components of the terminal and provides detailed discussions of the operation of each functional component.
- SECTION V **Maintenance:** This section contains preventative and corrective maintenance procedures, adjustment procedures, and removal and replacement procedures for all replaceable assemblies.
- SECTION VI **Assembly Drawings and Parts Lists:** This section contains assembly drawings and parts lists for all replaceable assemblies.
- SECTION VII **Diagrams:** This section contains logic diagrams.
- APPENDIX A **Character Set Dot Matrix**
- APPENDIX B **Character and Control Codes**
- APPENDIX C **Terminal Options and Accessories**
- APPENDIX D **Ribbon and Paper Recommendations**
- APPENDIX E **Installation Instructions For Option Kits**
- APPENDIX F **Glossary of Logic Signals**
- APPENDIX G **Recommended Data Set Options and Cabling Information**

TABLE OF CONTENTS

Paragraph	Title	Page
SECTION I. GENERAL DESCRIPTION		
1.1	Introduction	1-1
1.2	Features and Specifications	1-2
1.3	Options	1-3
1.4	Accessories	1-4
1.5	Identification	1-4
SECTION II. INSTALLATION		
2.1	Introduction	2-1
2.2	Space Requirements	2-1
2.3	Power Cord Connection	2-2
2.4	Paper Loading	2-3
2.5	Ribbon Installation	2-4
2.6	Power-On Procedure	2-5
2.7	Power-Off Procedure	2-6
2.8	Operational Checkout and Printhead Adjustment	2-6
2.8.1	Model 820 KSR	2-6
2.8.2	Model 820 RO	2-7
2.8.3	Printhead Adjustment Procedure for Model 820 KSR and RO Terminals	2-7
2.8.4	Model 820 KSR and RO Self-Test Procedures	2-8
2.9	Configuration Parameter Selection	2-9
2.9.1	Configuration Set Selection (01-9)	2-11
2.9.2	Communications Mode (11-16)	2-11
2.9.3	Communications Rate	2-11
2.9.4	Parity (31-39)	2-12
2.9.5	Line Control (61-67)	2-13
2.9.6	Transmission Control (71-72)	2-14
2.9.7	Terminal Control (81-89, 91-93)	2-15
2.9.8	Programmable Parameters (ABM, LTA, ENTER)	2-16
2.9.9	Configuration Report	2-17
2.9.9.1	Local Mode or Standby Mode (KSR)	2-17
2.9.9.2	Local Mode or Standby Mode (RO)	2-17
2.9.9.3	Line Mode (DFC option only) KSR and RO	2-18
2.10	Configuration Parameter Entry	2-18
2.10.1	Initiate Configuration	2-18
2.10.2	Review Current Configuration	2-18
2.10.3	Enable Mutually Exclusive Parameters	2-19
2.10.4	Enable ON/OFF Parameters	2-19
2.10.5	Disable ON/OFF Parameters	2-19
2.10.6	Program the ABM, LTA, and ENTER Key	2-19
2.10.7	Configuration Errors	2-20
2.10.8	Terminate Configuration	2-20
2.11	Communications Interface Cable Connection	2-20
SECTION III. OPERATION		
3.1	Introduction	3-1
3.2	Operator's Panel	3-2

TABLE OF CONTENTS (Continued)

Paragraph	Title	Page
3.2.1	Control Panel	3-3
3.2.1.1	LINE/●/LCL Switch	3-3
3.2.1.2	VIEW/OFF Switch (Model 820 KSR Only)	3-3
3.2.1.3	LINE RDY and CARR RCV Indicators	3-3
3.2.1.4	Terminal Status Display (TSD)	3-4
3.2.1.5	Special Function Keys	3-6
3.2.2	Typewriter Keyboard (Model 820 KSR Only)	3-7
3.2.2.1	Code Generating Keys	3-7
3.2.2.2	HERE IS Key	3-7
3.2.2.3	Numeric Keypad Option	3-7
3.2.3	Operator's Keypad (Model 820 RO Only)	3-7
3.2.4	CONFIGURE/OPERATE Switch (Model 820 KSR Only)	3-8
3.2.5	Audible tone	3-9
3.3	Printer	3-9
3.3.1	Character Set and Font	3-9
3.3.2	Format Parameters	3-9
3.3.3	End-Of-Line Alarm	3-9
3.3.4	Printer Operation	3-9
3.3.4.1	Printable Characters	3-9
3.3.4.2	Automatic New Line	3-11
3.3.4.3	Control Characters	3-11
3.3.5	Setting the Top-Of-Form	3-12
3.3.5.1	Method 1 (Using ↑ and ↓)	3-12
3.3.5.2	Method 2 (Using ESC)	3-12
3.3.6	Paper-Out Condition	3-12
3.3.7	Mechanism Failure Detection	3-12
3.3.8	Data Buffering and Printer Throughput	3-12
3.4	Communications Interface	3-13
3.4.1	Interface Signals	3-13
3.4.2	Interface Signal Levels	3-15
3.4.3	Local Mode	3-15
3.4.4	Standby Mode	3-15
3.4.5	LINE Mode	3-16
3.4.5.1	Full-Duplex Operation	3-16
3.4.5.2	Half Duplex (Without Reverse Channel) Operation	3-17
3.4.5.3	Half-Duplex with Reverse Channel Operation	3-18
3.4.5.4	No-LTA Operation (Half-Duplex Modes 11 and 12)	3-19
3.4.5.5	Console Operation	3-19
3.5	Options	3-20
3.5.1	Device/Forms Control (DFC)	3-20
3.5.2	Compressed Print	3-20
3.5.3	User-Defined Configuration Sets	3-23
3.5.4	Alternate Character Set Keyboard — ASCII/APL (Model 820 KSR Only)	3-23
3.5.5	Numeric Keypad (Model 820 KSR Only)	3-25
3.5.6	20 mA Current-Loop Interface	3-25
3.6	Operator's Reference Cards	3-26

SECTION IV. THEORY OF OPERATION

4.1	General	4-1
4.2	Power Supply	4-2

TABLE OF CONTENTS (Continued)

Paragraph	Title	Page
4.2.1	Input Voltage Selection and Rectification	4-3
4.2.2	Soft-Start Circuit	4-4
4.2.3	Blocking Oscillator Circuit	4-4
4.2.4	Reference Sensing Circuit	4-5
4.2.5	Secondary Filtering and Regulation Circuits	4-5
4.2.6	Power-Good Circuit	4-5
4.3	Terminal Controller Subsystem	4-5
4.3.1	The Z-80A Microprocessor	4-6
4.3.2	Z-80A CPU Timing	4-8
4.3.3	Terminal Controller Memory	4-11
4.3.3.1	Read-Only Memory	4-11
4.3.3.2	Nonvolatile Memory	4-11
4.3.3.3	Random Access Memory	4-12
4.3.3.4	Programmable Read-Only-Memory (Optional)	4-12
4.3.4	Memory Control Logic	4-12
4.3.5	System Clock	4-14
4.3.6	The Z-80A CTC Counter Timer Circuit	4-14
4.4	Operator Interface	4-14
4.4.1	Keyboard/Switch Scan	4-15
4.4.2	Keyboard Matrix	4-15
4.4.2.1	KSR Keyboard	4-15
4.4.2.2	RO Keyboard	4-15
4.4.2.3	Column Data	4-15
4.4.3	Terminal Status Displays and Indicators	4-17
4.4.4	Keyboard Interface	4-17
4.5	Communications Interface	4-18
4.5.1	Interface Signals	4-18
4.5.2	Signal Level Conversion	4-19
4.5.3	Serial I/O Controller	4-19
4.5.4	Current-Loop (TTY) Interface (Optional)	4-19
4.6	Ribbon Drive Subsystem	4-20
4.6.1	Ribbon Motor Drive	4-20
4.6.2	Ribbon Motor Direction	4-20
4.7	Paper Drive Subsystem	4-20
4.7.1	Paper Motor Driver Circuit	4-20
4.7.2	Paper-Out Detection	4-21
4.8	Printhead Carriage Drive	4-22
4.8.1	Printhead Positioning	4-22
4.8.2	Carriage Jam Detection	4-23
4.9	Character Printing	4-23

SECTION V. PREVENTIVE MAINTENANCE AND SELF-TEST PROCEDURES

5.1	Introduction	5-1
5.2	Preventive Maintenance	5-1
5.3	Self-Tests	5-2
5.3.1	Power-Up Diagnostic Tests	5-2
5.3.1.1	Indicator Test	5-2
5.3.1.2	RAM Test	5-3
5.3.1.3	ROM Test	5-3
5.3.1.4	Nonvolatile Memory Test	5-3
5.3.1.5	Audible Tone Test	5-3

TABLE OF CONTENTS (Concluded)

Paragraph	Title
5.4	Maintenance Tests
5.4.1	Barberpole Test
5.4.1.1	Alternate Character Barberpole Test
5.4.2	Run-In Test
5.4.3	Communications Test (KSR Only)
5.4.3.1	Using the EIA Plug
5.4.3.2	Acoustic Coupler Transmit Level Adjustments
5.4.4	Configuration Report
5.4.5	ROM Identification Report
5.5	Troubleshooting
5.6	Grounding Requirements
5.6.1	Chassis Ground
5.6.2	Signal Ground
5.6.3	System Requirements
5.6.3.1	Hard-Wired (Console) Applications
5.6.3.2	Data Set Applications
5.7	Assemblies Removal and Replacement
5.7.1	Full Opening of Terminal Cover
5.7.2	Removal and Replacement of the Keyboard Plenum
5.7.3	Removal and Replacement of the Fan Assembly
5.7.4	Removal and Replacement of the Keyboard Assembly (Keyboard PWB)
5.7.5	Removal and Replacement of the Logic PWB (Main Electronic PWB)
5.7.6	Removal and Replacement of Logic PWB Battery
5.7.7	Removal and Replacement of PWB Fuse (250V, 3A)
5.7.8	Removal and Replacement of Paper Drive Motor
5.7.9	Removal and Replacement of the Tractor Assembly
5.7.10	Removal and Replacement of the Printhead
5.7.11	Printhead Ribbon Guide Adjustment
5.7.12	Removal and Replacement of the Ribbon Drive Subassembly
5.7.13	Removal of the Carriage Motor and Mechanism (or Wire Rope or Mechanism)

SECTION VI. ASSEMBLY DRAWINGS AND LIST OF MATERIALS

SECTION VII. DIAGRAMS

APPENDICES

APPENDIX A	Character Set Dot Matrix
APPENDIX B	USASCII/APL Codes
APPENDIX C	Model 820 KSR/RO Terminals Options and Accessories
APPENDIX D	ONMI 800 Model 820 Printer Ribbon and Paper Recommendations
APPENDIX E	Installation of Optional Kits
APPENDIX F	Glossary of Model 820 KSR and RO Signals
APPENDIX G	Recommended Data Set Options and Cabling Information

INDEX

LIST OF ILLUSTRATIONS

Figure No.	Title	Page
1-1	<i>Omni 800</i> Model 820 KSR Terminal	1-1
1-2	<i>Omni 800</i> Model 820 RO Terminal	1-2
2-1	Physical Dimensions	2-1
2-2	Model 820 KSR/RO Rear Panel	2-2
2-3	Paper Loading	2-3
2-4	Ribbon Installation	2-4
2-5	Power-On Procedure Switches	2-5
2-6	Controls for Model 820 KSR Self-Test	2-6
2-7	Controls for Model 820 RO Self-Test	2-7
2-8	Self-Test Results	2-8
3-1	Model 820 KSR and RO Major Functional Components	3-1
3-2	The Operators Panel, Model 820 KSR	3-2
3-3	The Operators Panel, Model 820 RO	3-2
3-4	CONFIGURE/OPERATE Switch	3-8
3-5	Format Parameters	3-10
3-6	APL Keyboard	3-24
3-7	Control Panel, USASCII/APL Option	3-24
3-8	Numeric Keypad	3-25
4-1	Model 820 KSR/RO Simplified Functional Block Diagram	4-1
4-2	Power Supply Block Diagram	4-2
4-3	Input Voltage Selection and Rectification	4-3
4-4	Soft-Start Circuit	4-4
4-5	Terminal Controller Subsystem	4-6
4-6	Z-80A Architecture	4-7
4-7	Basic CPU Timing Example	4-8
4-8	Instruction Op code Fetch With One Wait State	4-9
4-9	Interrupt Request/Acknowledge Cycle	4-9
4-10	Memory Read Or Write Cycles	4-10
4-11	Memory Read Or Write Cycles With One Wait State	4-10
4-12	Input Or Output Cycles	4-11
4-13	Memory Map	4-12
4-14	Memory Mapped I/O	4-13
4-15	I/O Devices	4-14
4-16a	Keyboard Matrix Simplified Diagram (Model 820 KSR)	4-16
4-16b	Keyboard Matrix Simplified Diagram (Model 820 RO)	4-16
4-17	Terminal Displays, Simplified Diagram	4-17
4-18	Keyboard PWB Simplified Diagram	4-18
4-19	Asynchronous Data Format	4-19
4-20	Printing the Letter "E"	4-24
5-1	Printhead Area, Guide Rods, and Ribbon Guide	5-2
5-2	Normal Results of Barberpole Test	5-4
5-3	Logic PWB Battery Details	5-16
A-1	Standard USASCII Character Font	A-2
A-2	Control Character Font	A-3
A-3	United Kingdom Character Font	A-4

LIST OF ILLUSTRATIONS (Concluded)

Figure No.	Title	Page
A-4	German Character Font	A-5
A-5	Swedish/Finnish Character Font	A-6
A-6	Denmark/Norway Character Set	A-7
A-7	Standard Katakana Character Font	A-8
A-8	APL Character Font	A-9
B-1	Model 820 KSR Control Character Keyboard Layout	B-1
B-2	English Keyboard (UKF), Model 820 KSR Only	B-2
B-3	Model 820 KSR German Keyboard Option	B-3
B-4	Danish/Norwegian Code Chart	B-4
B-5	Danish/Norwegian Keyboard (DNF) and Optional Numeric Pad, Model 820 KSR Only	B-5
B-6	Model 820 KSR Katakana Keyboard Option	B-6
B-7	French Keyboard (FRF) and Optional Numeric Pad, Model 820 KSR Only	B-7
G-1	Model 820 Current Loop Interface Configurations	G-1

LIST OF TABLES

Table No.	Title	Page
1-1	Model 820 Specifications	1-3
1-2	Model 820 KSR Hardware Configuration Abbreviations	1-4
2-1	Self-Test Patterns of the Model 820 KSR and RO Terminals	2-9
2-2	Configuration Codes	2-9
3-1	LINE RDY and CARR RCV Indicators	3-4
3-2	Interpreting Terminal Status Display (TSD) Functions	3-5
3-3	Status Codes	3-6
3-4	Audible Tone Operation	3-9
3-5	Interface Signals	3-14
3-6	Device Control Commands for Model 820 KSR and RO Terminals	3-21
3-7	Forms Setup Commands for Model 820 KSR and RO Terminals	3-22
4-1	Motor Driver Acceleration Control Output	4-22
5-1	Option PROM/ROM Part Numbers and Locations	5-12
5-2	Strappable Option On Logic PWB (999694-0001)	5-13
B-1	USASCII/APL Character Set	B-1
B-2	UKASCII Code Chart	B-2
B-3	German ASCII Code Chart	B-3
B-4	Swedish/Finnish ASCII Code Chart	B-4
B-5	Danish/Norwegian Code Chart	B-5
B-6	Standard Katakana Code Chart	B-6
B-7	USASCII/APL Character Set	B-7
C-1	Model 820 KSR Terminal Options	C-1
C-2	Model 820 KSR Terminal Accessories	C-2
G-1	Recommended Data Set Options	G-1
G-2	Summary of Cables	G-3
G-3	113A/103, 202/212 Data Set Cable (TI Part No. 993205-0001)	G-4
G-4	Data Terminal Cable (TI Part No. 0993210-0001)	G-4
G-5	770 Data Terminal Cable (TI Part No. 993239-0001)	G-5
G-6	Terminal Adapter Cable Pin Assignments (TI Part No. 2263351-0001)	G-5
G-7	733 ASR Terminal Cable, 1200 Baud (TI Part No. 959372-0002)	G-6
G-8	742 Terminal Cable (TI Part No. 969626-0001)	G-6
G-9	742 Auxiliary Cable (TI Part No. 973265-0001)	G-6
G-10	743 Terminal Cable (TI Part No. 983848-0001)	G-6
G-11	763/765 Data Terminal Cable Pin Assignments (TI Part No. 2263350-0001)	G-6
G-12	TTY Current Loop Interface Cable Part No. 994403-0001	G-6
G-13	Asynch/Synch EIA Cable (TI Part No. 2207634-0001)	G-7

SECTION I

GENERAL DESCRIPTION

1.1 INTRODUCTION

The Texas Instruments *Omni 800** Model 820 Keyboard-Send Receive (KSR) Terminal shown in Figure 1-1 consists basically of

- A *printer* which provides one original and up to five copies of data received via a *communications interface*.
- An *operator's panel* which permits entry of data on the *keyboard* for transmission to a host system or other terminals via a *communications interface*.

The Texas Instruments *Omni 800** Model 820 Receive-Only (RO) Terminal shown in Figure 1-2 consists basically of:

- A *printer* which provides one original and up to five copies of data received via a *communications interface*.
- An *operator's panel* which allows an operator to select the mode of operation for the terminal and to control some of the printer functions.

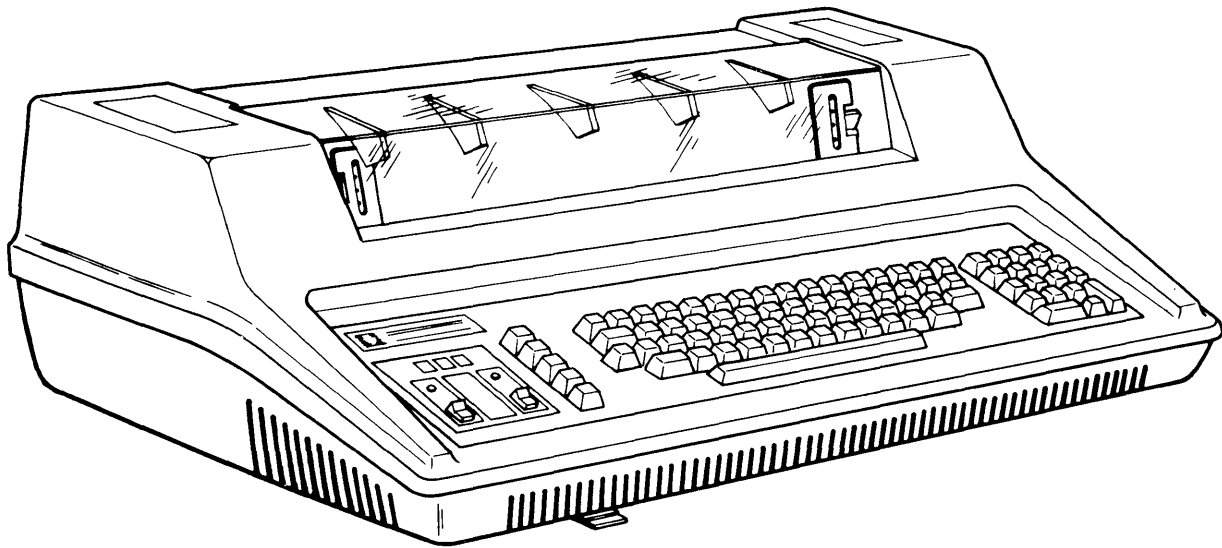

Figure 1-1. *Omni 800* Model 820 KSR Terminal

*Trademark of Texas Instruments

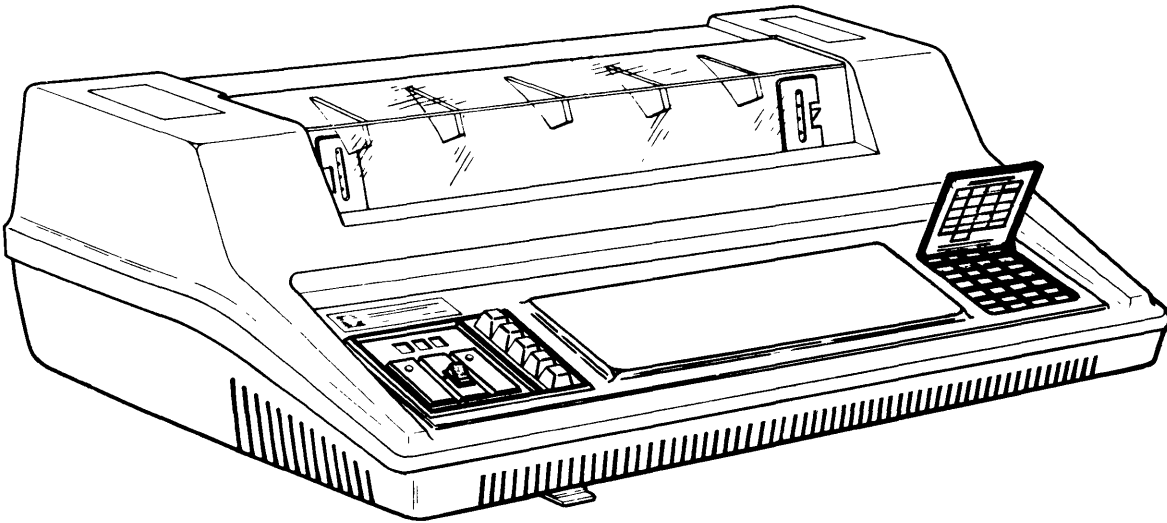

Figure 1-2. Omni 800 Model 820 RO Terminal

1.2 FEATURES AND SPECIFICATIONS

The Model 820 KSR is a compact self-contained data terminal, similar in appearance to an office typewriter, which communicates in an attended or unattended mode via appropriate transmission media. The Model 820 KSR is highly suitable for conversational, data/text entry, inquiry-response, and computer console applications.

The Model 820 RO is similar in appearance and function to the Model 820 KSR, except that the RO terminal has an *operator's keypad* instead of a true keyboard. It communicates in an attended or unattended mode via appropriate transmission media, and is most suitable for those applications merely requiring a hard-copy, medium speed output device.

The Model 820 terminals transmit and receive serial, asynchronous data at rates from 110 to 9600 baud and are capable of printing at speeds up to 150 characters per second (CPS). Printing is done by means of a serial, wire-matrix impact mechanism which prints on conventional paper and features multiple copy, wide carriage, and optional forms handling capabilities. An internal buffer memory enables the Model 820 terminals to receive burst data at transmission rates which exceed its maximum printing speed.

The control electronics consists primarily of a stored-program microprocessor system which provides a high degree of flexibility with the fewest possible components. All operating parameters (e.g., communications rate, parity, etc.) can be altered from the operator's panel, thereby eliminating the need for hardware strappable options and minimizing special operator controls. The modular construction of the electrical and mechanical assemblies greatly facilitates maintenance and repair.

Table 1-1 lists the specifications for the Model 820 KSR and RO data terminals.

Table 1-1. Model 820 Specifications

POWER REQUIREMENTS

Voltage: 90-130 Vac, 47-63 Hz, single phase
180-260 Vac, 47-63 Hz, single phase

Power: 50 VA max, idle
75 VA average printing
150 VA max. executing form feed

PHYSICAL DIMENSIONS

Size: 660.4 mm (26.0 in.) W × 533.4 mm (21.0 in.) D ×
209.5 mm (8.25 in.) H
Weight: 18.6 kg (41 pounds) excluding options

ACOUSTIC NOISE

Level: Less than 60 dB (A-weighted), measured 0.9 meter (3.0 feet) directly in front under free field conditions while printing at 150 characters per second

ENVIRONMENTAL (OPERATING)

Temperature: 5 °C to 40 °C
Relative Humidity: 5% to 90% (no condensation)
Altitude: To 3046 m (10,000 feet)

PRINTER

Method: Wire matrix impact
Speed: 150 characters per second
Pattern: 9 x 7 dot matrix
Character Set: 95 ASCII plus 33 control character graphics plus parity error symbol
Character Per Line: 132 max. (218 w/Compressed Print Option)
Character Spacing: 10 per 25.4 mm (1 in.) (or 16.5/in.)
Line Spacing: 6 per 25.4 mm (1 in.) or 8 per 25.4 mm (1 in.)
Paper Drive: 2 pinfeed tractors (4 pin)
Paper Feed: Rear or bottom
Paper Width: 76.2 mm (3.0 in.) to 377.8 mm (14.875 in.)
Paper Type: Continuous feed, fanfold, or multipart (original + 5 copies)

Ribbon: 54.8 m (60 yards) or 36.58 m (40 yards), auto reversing
Line Feed Time: 30 milliseconds
Paper Slew Rate: 190.5 mm (7.5 in.) per second
Adjustments: Forms width, thickness, and alignment
Form Length: 279.4 mm (11 in.) (RO programmable up to 355.6 mm (14 inches) long)
Detection: Paper-out, carriage jam

KEYBOARD

<i>Type:</i>	Full ASCII	Hex/Special
<i>Layout:</i>	Typewriter	Calculator
<i>Rollover:</i>	N-Key	n/a

Indicators: Terminal and Communications status

KSR

RO

COMMUNICATIONS

Interface: EIA RS-232-C
Type Transmission: Asynchronous
Code: ASCII
Speeds: 110, 200, 300, 600, 1200, 2400, 4800, 9600 Baud
Modes: Full duplex, half duplex, half duplex with reverse channel
Parity: Transmit odd, even, mark, space — Check-odd, even, none
Receive Buffer: 1280 characters
Line Control: Autoanswer, autodisconnect, printer ready/busy
Identification: 21-character answerback memory

OPTIONS

Printer: Compressed print (16.5 characters-per inch) 218 characters per line maximum
Control: Device/Forms Control
Keyboard: 18 key numeric keypad (KSR only)
APL/ASCII keyboard (KSR only)
International keyboards (KSR only)
Interface: dc current loop
Configuration: User-specifiable default parameter sets (up to eight)
User-specifiable protected parameter sets (up to eight)
Protected answerback memory

1.3 OPTIONS

The following features are available as options for the Model 820.

- Compressed print** — provides 16.5 and 10.0 characters per 25.4 mm (1 inch) horizontal pitch and allows up to 218 characters per line in 16.5 character pitch.
- Device/forms control** — provides extensive terminal and format capabilities, including horizontal and vertical tabs, margin and form length control, printer ON/OFF, etc.
- Numeric Keypad (KSR only)** — an 18-key cluster, including a user-programmable ENTER key, similar to a calculator keyboard for fast number entry.
- Alternate character sets** — APL, Katakana.
- International character sets** — England, France, Germany, Denmark/Norway and Sweden/Finland.

International Keyboards (KSR only) — APL, Katakana, England, France, Germany, Denmark/Norway, and Sweden/Finland

Communications Interface — dc current loop

Configuration sets — provides up to eight user-defined configuration-parameter sets to facilitate the use of the terminal with a variety of host systems. Also, sets can be obtained with a protected, permanent answerback memory message.

1.4 ACCESSORIES

The following useful accessories are available for the Model 820 KSR and RO:

- Paper basket — holds the printed output
- Terminal stand — for user convenience
- Noise enhancement kit — significantly reduces noise
- Interface cables — for console and special connections.

1.5 IDENTIFICATION

The particular configuration of the Model 820 KSR or RO may be identified by the *printer configuration label* affixed inside the terminal cover. Table 1-2 defines the abbreviations used to identify the Model 820 terminals.

Table 1-2. Model 820 KSR Hardware Configuration Abbreviations

PRINTER CONFIGURATIONS		COMMUNICATION OPTIONS	
BSC	Basic Model 820 Terminal	CTY	20-mA dc current loop
115 V	115 volt operation		
220 V	220 volt operation		
CSA	Standard EIA RS-232-C interface		
PSF	Standard printer (10 characters per inch)		
PCF	Compressed print option (10 and 16.5 characters per inch)		
MFG	Device/Forms Control (DFC) option		
		CONFIGURATION OPTIONS	
		MDP	Default configuration option
		MPP	Protected configuration option
		MAP	Protected ABM option
KEYBOARD OPTIONS		CHARACTER SET SUBOPTIONS	
KFS	Standard full ASCII (KSR)	UKF	United Kingdom ASCII
KFN	Standard full ASCII with numeric pad (KSR)	DNF	Danish/Norwegian ASCII
KAS	APL/ASCII (KSR)	SFF	Swedish/Finnish ASCII
KAN	APL/ASCII with numeric pad (KSR)	FRF	French ASCII
KKS	Katakana/ASCII (KSR)	GRF	German ASCII
KKN	Katakana/ASCII with numeric pad (KSR)		
KES	European/ASCII (KSR)		
KEN	European/ASCII with numeric pad (KSR)		
KCP	Standard RO Control Panel (RO)		

SECTION II INSTALLATION

2.1 INTRODUCTION

This section provides suggestions for selecting a suitable location for the terminal, installing the supplies, making power and interface connections, applying power, performing checkout procedures, and selecting the appropriate operating parameters. This discussion assumes that the Model 820 KSR/RO has been removed from the shipping container and that all shipping fixtures are removed from the terminal.

2.2 SPACE REQUIREMENTS

The Model 820 KSR or RO data terminal occupies a flat surface area 660 mm (26 inches) wide by 609 mm (24 inches) deep, including cable clearance of 76 mm (3 inches). Figure 2-1 lists the outline dimensions of the Model 820 KSR/RO including space for adequate ventilation. Take particular care not to block the cooling fan intake and exhaust louvers located on all four sides of the terminal.

An unobstructed paper feed path must be provided behind or below the terminal for the paper supply. A method of holding the printer output paper must also be provided if the optional paper basket accessory is not used. The terminal should not be operated in an environment where humidity, temperature, or other specifications listed in Table 1-1 may be exceeded. A sturdy table capable of adequately supporting 18.6 kilograms (41 pounds) is suitable if the optional floor mounting stand is not used. Regardless of the mounting selected, take care to ensure that the paper chute underneath the terminal does not bear any weight of the terminal and is not subjected to any pressure which could deform it.

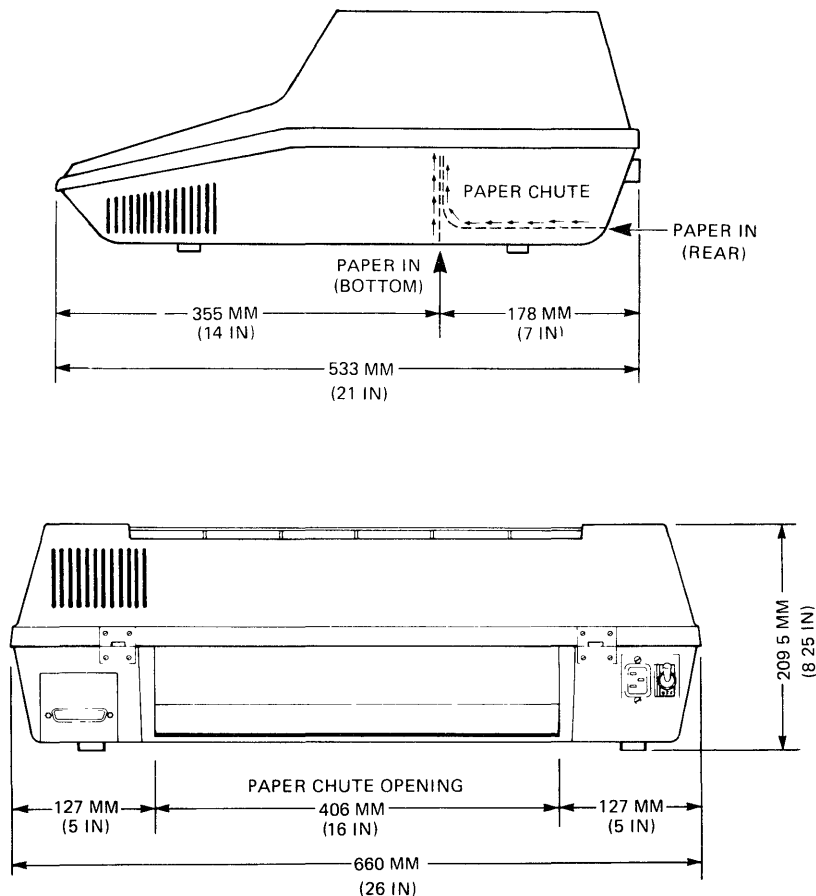

Figure 2-1. Physical Dimensions

2.3 POWER CORD CONNECTION

Note the *printer configuration label* affixed to the inside of the cover to determine the input voltage requirements and then position the terminal close to an appropriately grounded electrical outlet so that the supplied power cord can be connected. Referring to Figure 2-2, locate the *power ON/OFF switch* and the *power cord receptacle* at the rear of the Model 820 KSR and proceed as follows:

- a. Ensure that the power ON/OFF switch is in the OFF (down) position.
- b. Attach the female connector of the power cord to the terminal power cord receptacle (next to the ON/OFF switch).
- c. Attach the male connector of the power cord to the electrical outlet.

WARNING

To ensure safe operation of the Model 820 KSR terminal, always use a properly grounded power source with the correct voltage, frequency, and current capacity.

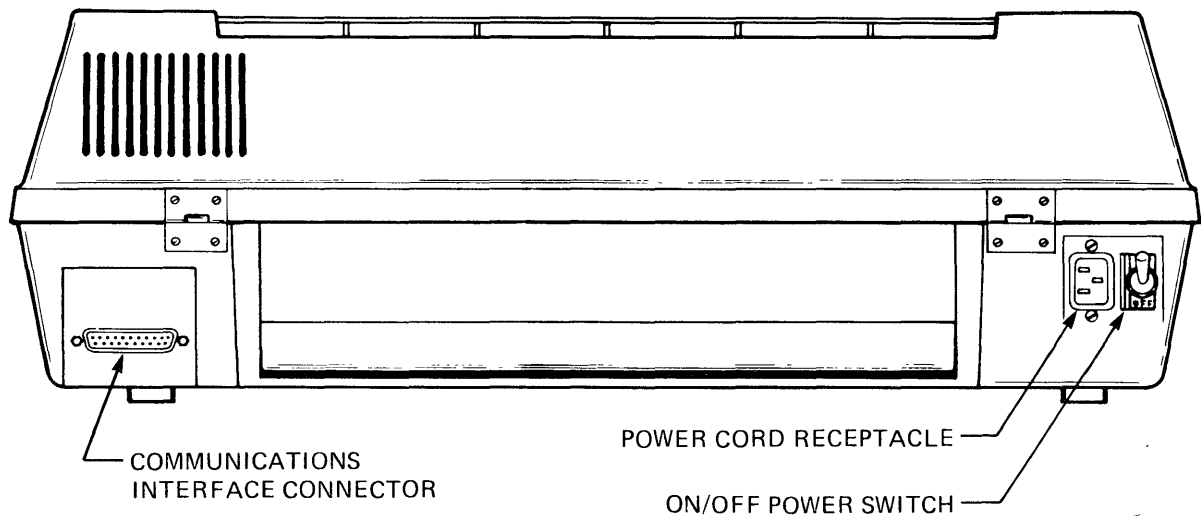

Figure 2-2. Model 820 KSR/RO Rear Panel

2.4 PAPER LOADING

The Model 820 KSR or RO will accommodate continuous form paper with standard sprocket holes on each side in widths from 76.2 to 377.8 mm (3.0 to 14.875 inches). Single or multipart forms meeting the specifications of TI Publication 0999860-9701, *Omni 800 Model 820 Printer Ribbon and Paper Recommendations* (Appendix D) may be used. Referring to Figure 2-3, locate the controls for *forms thickness adjustment (adjust lever)* and *forms width adjustment (flaps)* and proceed as follows:

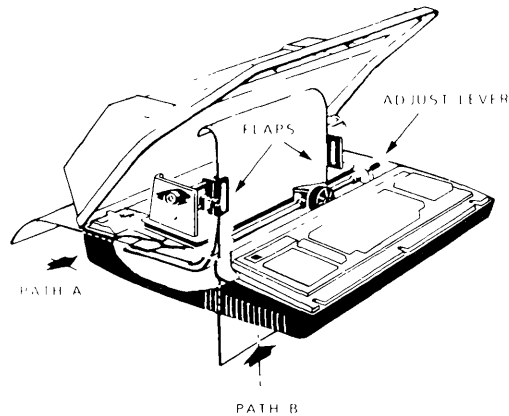

Figure 2-3. Paper Loading

- a. Lift the terminal cover and open the *flaps* on both paper tractors.
- b. Using the *printhead adjust lever*, move the printhead away from the platen.
- c. Feed the paper into either the rear paper chute (path A) with the printing side of the paper down or the bottom paper chute (path B) with the printing side of the paper facing you until the paper appears at the platen.
- d. Loosen the locking lever on the right tractor and move the tractor left or right as necessary to accommodate the paper width.
- e. Place the paper in both tractors so that corresponding holes and pins engage the paper on both sides.
- f. Close both tractor flaps.
- g. Adjust the right tractor as necessary to remove slack in the paper and then tighten the locking lever.
- h. Check that the paper supply is aligned in the paper chute and that the paper does not rub the side of the paper chute.
- i. Reposition the printhead using the adjust lever.
- j. Close the terminal cover.

2.5 RIBBON INSTALLATION

The Model 820 KSR and RO use a nylon ribbon mounted on two spools as described in TI Publication 0999860-9701, *Omni 800 Model 820 Printer Ribbon and Paper Recommendations* (included in Appendix D).

CAUTION

Use of ribbons which do not meet TI specifications may seriously shorten printhead life and void the warranty.

Referring to Figure 2-4, proceed as follows:

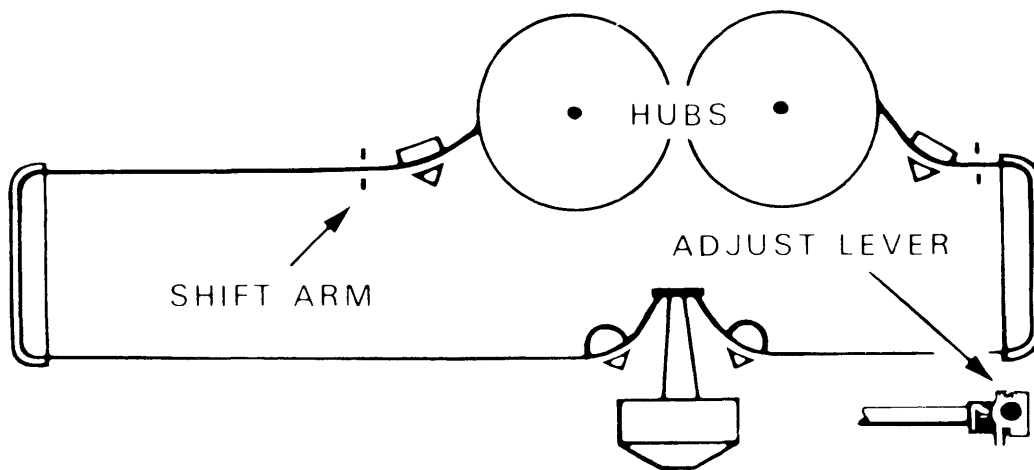

Figure 2-4. Ribbon Installation

- a. Lift the terminal cover.
- b. Using the *printhead adjust lever*, move the printhead away from the platen.
- c. Place the full ribbon spool on either hub so that the ribbon exits from the far side.
- d. Feed the ribbon along the path as shown in Figure 2-4.
- e. Place the empty ribbon spool on the other hub and remove slack from the ribbon by manually rotating one of the spools in the appropriate direction.
- f. Check that the empty spool *ribbon eyelet* is between the spool and the *shift arm* and that the ribbon is properly positioned between the *vertical ribbon guides* on each side of the printer.
- g. Reposition the printhead using the adjust lever.
- k. Close the terminal cover.

2.6 POWER-ON PROCEDURE

Referring to Figure 2-5, locate the *line/•/LCL switch*, and the *terminal status display* and proceed as follows:

- a. Set the LINE/•/LCL switch to the LCL position (lower edge depressed). The LINE/•/LCL switch is the only switch on the Model 820 RO operator's control panel. See Figure 2-7.

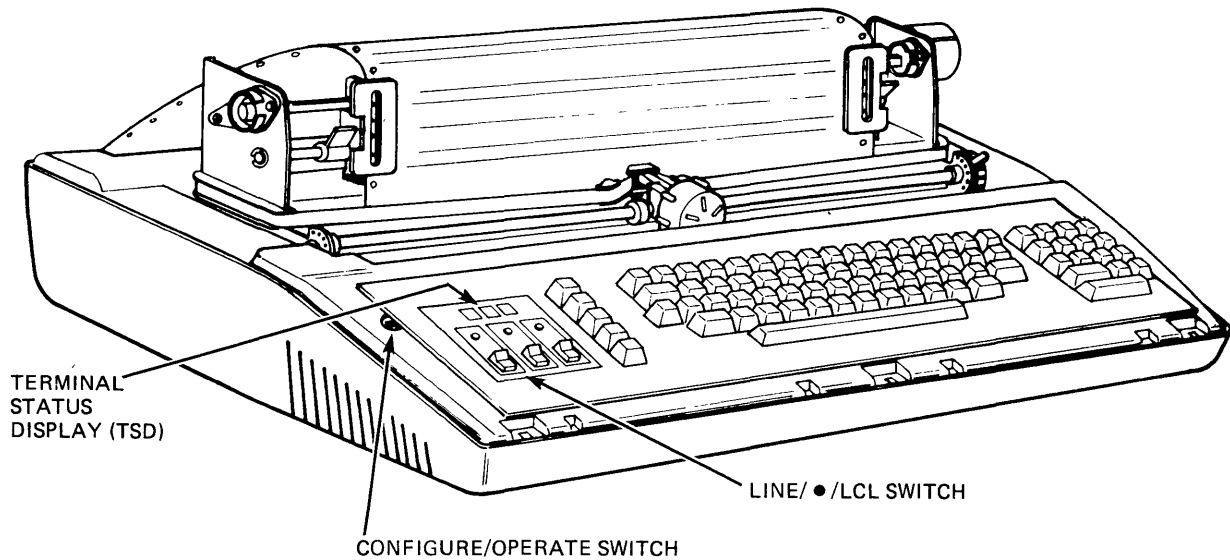

Figure 2-5. Power-on Procedure Switches

- b. Set the power ON/OFF switch to the ON position (up).
- c. Ascertain that the following events occur:
 - The *terminal status display* (TSD) shows $\square\square\square$ and the LED indicators are illuminated
 - The printhead aligns to the left margin
 - The audible tone sounds
 - The TSD shows $\square\square\square$ (or the left margin setting if the left margin is not set to column 1) and the LED indicators go off.

NOTE

If it shows \square in the leftmost digit, the machine has powered up in CONFIGURE mode. If the Model 820 is a KSR version, lift the terminal cover and set the CONFIGURE/OPERATE switch to OPERATE. The display should now show the left margin column number. An RO version cannot power up in CONFIGURE mode.

2.7 POWER-OFF PROCEDURE

To remove power from the terminal, simply set the power ON/OFF switch to the OFF position (down). The Model 820 terminals retain operating and format parameters in a nonvolatile memory so that the terminal is ready to operate when power is again applied.

2.8 OPERATIONAL CHECKOUT AND PRINthead ADJUSTMENT

CAUTION

Do not operate the printer without ribbon and paper installed. Printhead damage will occur and the warranty may be voided.

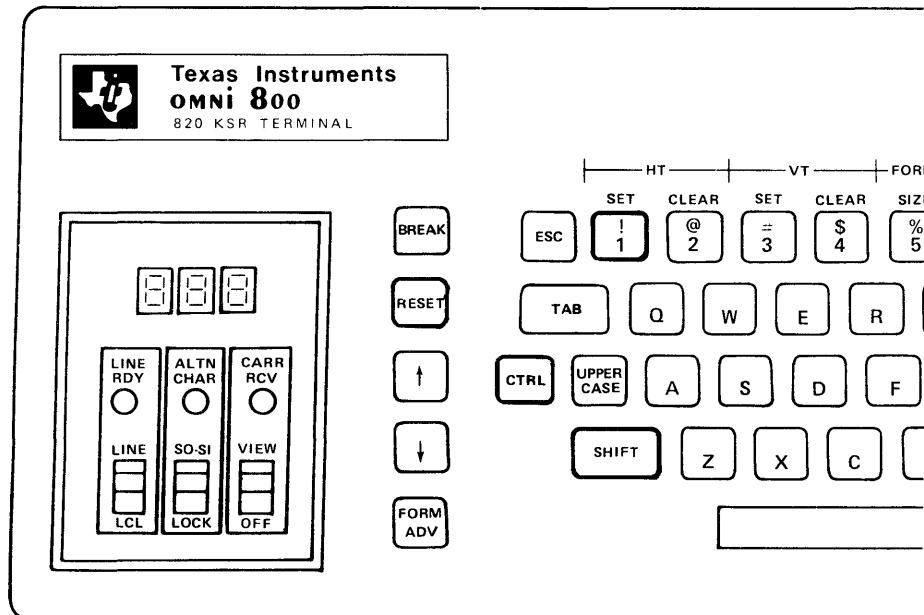

Figure 2-6. Controls for Model 820 KSR Self-Test

2.8.1 MODEL 820 KSR. Referring to Figure 2-6, locate the CTRL, SHIFT, !/1, and RESET keys on the operator's panel and proceed as per Section 2.8.3.

2.8.2 MODEL 820 RO. Referring to Figure 2-7, locate the TEST and 1 keys on the operator's keypad and the RESET key on the operator's control panel. Proceed as follows:

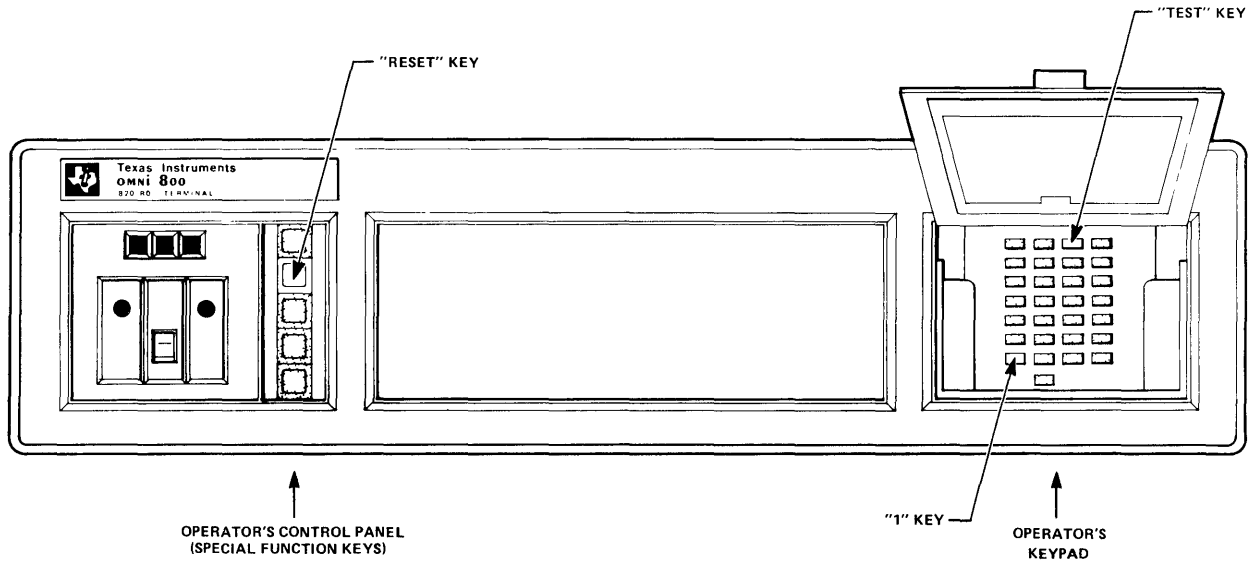

Figure 2-7. Controls for Model 820 RO Self-Test

2.8.3 PRINTHEAD ADJUSTMENT PROCEDURE FOR MODEL 820 KSR AND RO TERMINALS.

- a. Switch the LINE/●LCL switch to LCL.
- b. Initiate the self-test on the Model 820 KSR by depressing the **CTRL** and **SHIFT** keys and then momentarily depressing the **! / 1** key while the others are still down. Then release all keys. The self-test is initiated on the RO machine by depressing the **TEST** and **1** keys in sequence.
- c. Observe that a repetitive, ripple pattern (called a *barberpole*) is printed and that the TSD displays **777**, flashing.
- d. If the printed characters are partially formed or have missing dots as shown in Figure 2-7a, the printhead is set too far from the platen: Correct this malfunction by rotating the adjust lever toward the rear of the terminal.
- e. If the printed characters are smeared as shown in Figure 2-7b, the printhead is set too close to the platen: Correct by rotating the adjust lever toward the front of the terminal.
- f. If the characters are clearly formed and not smeared as shown in Figure 2-7c, the printhead is satisfactorily adjusted.
- g. Terminate the self-test by momentarily pressing the **RESET** key.

```

! "#$%&'()*+,-./0123456789:;<=>?@ABCDEFGHIJKLMNPOQRSTUVWXYZ
! "#$%&'()*+,-./0123456789:;<=>?@ABCDEFGHIJKLMNPOQRSTUVWXYZ
! "#$%&'()*+,-./0123456789:;<=>?@ABCDEFGHIJKLMNPOQRSTUVWXYZ[\
! "#$%&'()*+,-./0123456789:;<=>?@ABCDEFGHIJKLMNPOQRSTUVWXYZ[\ ]

```

a. Printhead too far from platen

```

! "#$%&'()*+,-./0123456789:;<=>?@ABCDEFGHIJKLMNPOQRSTUVWXYZ ]
! "#$%&'()*+,-./0123456789:;<=>?@ABCDEFGHIJKLMNPOQRSTUVWXYZ [
! "#$%&'()*+,-./0123456789:;<=>?@ABCDEFGHIJKLMNPOQRSTUVWXYZ [\ ]
! "#$%&'()*+,-./0123456789:;<=>?@ABCDEFGHIJKLMNPOQRSTUVWXYZ [\ ]

```

b. Printhead too close to platen

```

! "#$%&'()*+,-./0123456789:;<=>?@ABCDEFGHIJKLMNPOQRSTUVWXYZ
! "#$%&'()*+,-./0123456789:;<=>?@ABCDEFGHIJKLMNPOQRSTUVWXYZ [
! "#$%&'()*+,-./0123456789:;<=>?@ABCDEFGHIJKLMNPOQRSTUVWXYZ [\
! "#$%&'()*+,-./0123456789:;<=>?@ABCDEFGHIJKLMNPOQRSTUVWXYZ [\ ]

```

c. Printhead adjusted correctly

Figure 2-8. Self-Test Results

This self-test performs an operational checkout of 95 percent of the terminal electronics. If the correct test results are not observed, refer to Section 5, Maintenance.

Note that it may be necessary to readjust the printhead occasionally to compensate for ribbon wear.

2.8.4 MODEL 820 KSR AND RO SELF-TEST PROCEDURES. The Model 820 KSR and RO terminals each have several other self-test diagnostic pattern generators in their operating systems. These include the Alternate Character Set Barberpole (RO only) Pattern, the Run-In Test Pattern and the Communications Test Pattern. Table 2-1 explains the CTRL/SHIFT or TEST key sequences necessary to generate these patterns as well as their intended purpose and the appearance of their outputs.

Table 2-1. Self-Test Patterns of the Model 820 KSR and RO Terminals

Self-Test	KSR Key Sequence	RO Key Sequence	Results	Notes
Barberpole	CTRL SHIFT 1 (Simultaneously)	TEST 1 (Sequentially)	BARBERPOLE PATTERN (Fig. 2-8)	Exercises 95% of terminal functions
Alternate Character Set Barberpole	not available on basic KSR. On KSR with Alternate Character Set — Shift to alternate set and initiate normal barberpole sequence.	not available on standard RO. On RO with Alternate Character Set, depress TEST 2 (Sequentially)	ALTERNATE CHARACTER SET BARBERPOLE	Exercises 95% of terminal functions. Gives display of Alternate installed character set. If TEST 2 is depressed on an RO with no alternate character set, a standard barberpole pattern will be generated.
Run-In	CTRL SHIFT 6 (Simultaneously)	TEST 6 (Sequentially)	OKOKOK . . . (132 columns)	Exercises 95% of terminal functions. Heavily exercises printer mechanism and communications interface.
Communications Test	CTRL SHIFT 2 (Simultaneously) followed by any printable character	not available	nnnnnn . . (transmitted, where n is the character depressed last in the sequence)	Transmitted by the KSR only unless Code 82 is enabled, in which case it also receives at the configured baud rate. Used for adjusting transmit levels of modems. If 82 and a rate higher than 1200 baud is enabled, initiating the communications test will result in overflowing the receive buffer.

2.9 CONFIGURATION PARAMETER SELECTION

All host system-dependent operating parameters such as communications mode, baud rate, and parity are entered from the operators panel. These operating parameters are designated by two-digit codes called *configuration codes*. The configuration codes are summarized in Table 2-2.

Table 2-2. Configuration Codes

CODE	MEANING	OPTION REQUIRED
Predefined Configuration Selection (one only)		
01 to 08	Select corresponding predefined configuration set	YES
09	Select standard default configuration set	
Communications Mode Selection (one only)		
11	Half duplex (for use with type 202 data set)	
12	Half duplex & reverse channel (for use with type 202 data set)	
13+	Full duplex (for type 103, 113, 212 data sets)	
14	Full duplex & reverse channel ON for ready (for use as a console)	
15	Full duplex & reverse channel OFF for ready (for use as a console)	
16	Select current-loop option (same as code 14 plus enabled interface)	

Table 2-2. Configuration Codes (Continued)

CODE	MEANING	OPTIONS REQUIRED
Transmission Rate Selection (one only)		
21	110 baud	
22	200 baud	
23	300 baud	
24	600 baud	
25	1200 baud	
26	2400 baud	
27	4800 baud	
28	9600 baud	
29+	300/ 1200 baud (for use with type 212 data set with <i>speed-select</i> option)	
Parity Selection (one only)		
31	Odd parity, no parity check	
32+	Even parity, no parity check	
33	Odd parity, indication on error	
34	Even parity, indication on error	
35	Odd parity, indication plus printed symbol on error	
36	Even parity, indication plus printed symbol on error	
37	Parity bit mark, no parity check	
38	Parity bit space, no parity check	
39	Parity bit selects alternate character set (RO only)	
Line Control Parameters (no limit)		
60	Program line turnaround characters for half duplex (202)	
61	Enable failsafe disconnect	
62	Disconnect on receipt of EOT	
63	Disconnect on receipt of DLE EOT	
64	Disconnect on paper-out or carriage jam	
65	Enable no activity disconnect	
66	Enable no-LTA operation if any half-duplex mode is selected	
67	Enable transmission of CR and 1st LTA character upon RETURN from the keyboard (KSR only)	
Transmission Control Parameters (no limit)		
70	Program answer-back memory (ABM)	
71	Auto-trigger ABM on connection	
72	Enable print of ABM contents (local HERE IS or code 82 set)	
Terminal Control Parameters (no limit)		
80	Program ENTER key on numeric keypad	YES
81	Enable device & format control from the communication line	YES
82	Enable local copy of transmitted data	
83	Transmit DC3 or BREAK on printer-busy DC1 or LTA on ready	
84	Do "new line" on receipt of LF	
85	Do "new line" on receipt of CR	
86	Transmit CR LF when RETURN key is pressed (KSR only)	
87	Print all control characters	
88	Set compressed print (16.5 CPI) only	
89	Set absolute right margin at column 80	YES
91	Set 8 lines per inch spacing	
92	Enable automatic perforation skip	
93	Set absolute line length to 8 inches	
]]	Invalid configuration code has been entered	

+ Standard default parameter configuration set

2.9.1 CONFIGURATION SET SELECTION (01-09). A configuration set defines all operating parameters for a particular terminal application. The definition of the configuration set parameters is

- 01-08 — *User-defined configuration sets* are optional features of the terminal. The user may specify up to eight complete sets of configuration parameters which are identified by the codes 01-08. These sets are contained in the configuration PROM located in socket XU24 on the main 820 circuit board.
- 09 — *The default configuration set* has the following parameters enabled:
 - 13 - Full-duplex
 - 29 - Auto-select Baud Rate (300/1200 Baud)
 - 32 - Even parity, no parity check

2.9.2 COMMUNICATIONS MODE (11-16). The communications (or duplex) mode determines the protocol used in exchanging data with the host system. Note that one (and only one) of parameters 11-16 must be enabled all times. The Model 820 will permit only one of these parameters to be enabled at a time.

- 11 — *Half-duplex* refers to the use of a communications channel such as that provided by a Bell System 202 data set (or equivalent) which permits exchange of data in only one direction at a time. One to three line turnaround (LTA) characters may be configured for this communications mode. If this is not done and no-LTA operation is not selected (code 66), an audible tone will be sounded and error code 10 will be displayed on the Terminal Status Display. The function of LTA characters will be explained in Section 3.4.5.
- 12 — *Half-duplex with reverse channel* is similar to half-duplex, except a low-frequency secondary channel is used to provide circuit assurance from the receiving to the transmitting station.
- 13 — *Full-duplex* refers to the use of a communications channel such as that provided by a Bell System 212 data set (or equivalent) which permits simultaneous, bidirectional data exchange.
- 14 — *Full-duplex with reverse channel ON for ready* is used for console operation; i.e., for applications without a modem. The Model 820 Terminals switch the transmitted reverse channel (secondary request to send, circuit SCA) on for *ready* and off for *busy*.
- 15 — *Full-duplex with reverse channel OFF for ready* is identical to parameter 14, except that operation of the reverse channel is inverted.
- 16 — *Current-Loop Option* refers to the enabling of an optional 20 mA current-loop interface used to communicate with those systems having a TTY interface only. The standard EIA serial connector will exhibit the normal operating characteristics of parameter 14 whether or not the current-loop interface is in use, although if used, the current loop option requires the inserting of a shorting plug into the EIA connector, thus preventing use of the connector. This parameter may be enabled regardless of the installation status of the optional current-loop interface.

2.9.3 COMMUNICATIONS RATE. The communications (or baud) rate determines the maximum number of characters per second (CPS) that can be transmitted or received by the Model 820. The communications rate applies to both transmitted and received data. Note that one (and only one) baud rate must be enabled at all times. The Model 820 KSR and RO terminals will permit only one of these parameters to be enabled at any time.

- 21 — 110 baud is 10 CPS (characters per second transmitted and/or received)
- 22 — 200 baud is 20 CPS
- 23 — 300 baud is 30 CPS
- 24 — 600 baud is 60 CPS
- 25 — 1200 baud is 120 CPS
- 26 — 2400 baud is 240 CPS
- 27 — 4800 baud is 480 CPS
- 28 — 9600 baud is 960 CPS
- 29 — *Auto-select* is for use with Bell System 212 data sets (or equivalent) equipped with an automatic speed selection option. The Model 820 Terminals will operate at either 300 or 1200 baud, depending on the status of pin 12 of the EIA interface when the call is connected; OFF selects 300 baud, and ON selects 1200 baud. Pin 12 may be called received reverse channel, circuit SCF, Secondary Data Carrier Detect, or Secondary Received Line Signal Detector.

2.9.4 PARITY (31-39). The parity selection determines how the Model 820 processes the error bit of the transmitted and received data. Parity is always added to transmitted data. The parity of received data is either checked or ignored according to the selected parity parameter. If the parity of received data is checked, an error is noted in one of two ways. Note that one (and only one) parity parameter must be enabled at all times. Again, the Model 820 will not permit more than one parameter of this group to be enabled at any one time.

- 31 — Transmit odd parity, do not check received data
- 32 — Transmit even parity, do not check received data
- 33 — Transmit odd parity, indication on error*
- 34 — Transmit even parity, indication on error*
- 35 — Transmit odd parity, indication plus printed symbol on error†
- 36 — Transmit even parity, indication plus printed symbol on error†
- 37 — Transmit mark parity, do not check received data
- 38 — Transmit space parity, do not check received data
- 39 — Transmit space parity, parity bit in received data selects alternate character set (if present). This code is capable of being entered only on a Model 820 RO Terminal.

***Indicator on error** — the audible tone is sounded, and an error code is displayed.

†**Indication plus printed symbol** — the audible tone is sounded, an error code is displayed, and the erroneous character is replaced with the symbol 

2.9.5 LINE CONTROL (61-67). The line control parameters provide several *line disconnect options* for use with modem communications modes. In all cases the Model 820 KSR or RO accomplishes the disconnect by switching off *data terminal ready* (DTR) until *data set ready* (DSR) has been off for 3 seconds. These automatic line disconnect features are usually enabled when the Model 820 is to be used in an unattended environment. The line control parameters 66 and 67 implement alternate LTA (line turnaround) functions for the half duplex communication modes.

Note that any number of line control parameters may be enabled at any time.

- 61** — *Failsafe Disconnect*, when enabled, causes the Model 820 KSR to disconnect from the transmission line when certain abnormal conditions occur. The audible tone sounds momentarily, and a *failsafe disconnect* error code is displayed to the operator. The error display will be reset the next time the DSR signal comes on or the RESET key is actuated.

Failsafe disconnect occurs under the following conditions according to the communications mode:

Full-duplex

- No data carrier detect received within 22 seconds after data set ready (DSR) switched ON (wrong-number timeout).
- Carrier is OFF for 8 seconds after having been ON (loss of carrier timeout).

Half-duplex

- Carrier is OFF for 22 seconds after DSR comes ON unless the ABM autotrigger feature is enabled.
- Carrier is OFF for 8 seconds after a line turnaround character is transmitted.
- Clear to send (CTS) fails to switch ON within 8 seconds after request to send (RTS) comes ON.

Half-duplex with reverse channel

- Carrier is OFF for 22 seconds after circuit DSR comes ON.
- Carrier is OFF for 8 seconds after a line turnaround character is transmitted.
- Carrier is OFF for 8 seconds after having been ON, unless carrier turnoff was preceded by a transmitted “**break**” by the Model 820 KSR or receipt of a line turnaround character by either Model 820 terminal.
- CTS fails to come on within 8 seconds after RTS comes ON (CTS timeout).

In all cases, the *failsafe* code is not displayed if DSR switches off before the specified timeout elapses, or if disconnect is preceded by receipt of the configured disconnect character or character sequence.

- 62** — *Disconnect on receipt of EOT* causes the Model 820 KSR or RO to perform a line disconnect when the control character *EOT* is received.
- 63** — *Disconnect on receipt of DLE EOT* causes the Model 820 KSR or RO to perform a line disconnect when the control character sequence *DLE EOT* is received.
- 64** — *Disconnect on paper-out or carriage jam* (when enabled) causes the Model 820 KSR or RO to perform a line disconnect when the terminal detects either fault condition. If para-

meter 64 is disabled, a *busy* signal is issued when either condition occurs. The *busy* signal depends upon the communications mode:

- *Full-duplex* — timed break pulse (256-ms spacing signal) transmitted.
- *Half-duplex* — no response possible; request to send will be held off following receipt of next line turnaround character.
- *Half-duplex with reverse channel* — reverse channel (secondary request to send, circuit SCA) is turned OFF.

Enabling or disabling of parameter 64 has no effect upon the *busy* signal provided on the reverse channel when operating in one of the *console* modes (parameters 14, 15, 16); conversely, parameter 64 is unaffected by parameters 14, 15 and 16.

- 65 — *No-Activity Disconnect* causes the Model 820 KSR or RO to disconnect upon 3 continuous minutes inactivity on *both* the transmitter and receiver. The transmission or receipt of any data during any active period causes the timer to be reset to three minutes. This disconnect is independent of parameter 61.
- 66 — *No Line Turnaround Mode* for half-duplex operation is selected by this parameter. It is functional only in conjunction with parameters 11 or 12, but may be selected regardless of the duplex mode selected. No-LTA operation is explained in depth in Section 3.4.5.
- 67 — *Transmission of Carriage Return and the 1st LTA Character upon depression of RETURN key (KSR only)* transmits both a carriage return (ASCII 0D) and the first configured LTA character if and only if code 11 or 12 is selected and code 66 is not. Note: If parameter 86 is also enabled when parameter 67 is enabled for half-duplex or half-duplex with reverse channel mode with LTA characters, the sequence CR, LF, LTA will be transmitted for each RETURN key depression. The code generated for CTRL n will not be affected by this parameter.

2.9.6 TRANSMISSION CONTROL (71-72). The transmission control parameters provide automatic control of the *answer-back memory* (ABM). Note that any number of the transmission control parameters may be enabled at any time.

- 71 — *Auto-trigger ABM on connection* causes the programmed ABM message to be transmitted at the following times according to the enabled modem communications mode:
 - *Full-duplex* — 1.28 seconds after both DSR and CTS switch ON. RTS is switched ON when DSR comes ON. CTS ordinarily switches ON simultaneously with the carrier.
 - *Half-duplex* — similar to full-duplex except that the carrier is tested when DSR comes on. If the carrier is OFF for 220 milliseconds, indicating that no carrier is being received, RTS is switched ON and the ABM message is transmitted 1.28 seconds after CTS comes ON. If the carrier is ON within 220 milliseconds after DSR comes ON, the Model 820 remains in receive mode until the first line turnaround. The ABM message is then transmitted at the same 1.28-second delay after CTS switches ON.
 - *Half-duplex with reverse channel* — identical to half-duplex except that reverse channel must be received before the ABM message is transmitted.

NOTE

In both *half-duplex* and *half-duplex with reverse channel* the ABM should be programmed to include a line turnaround character as the last character of the message if it is intended that the Model 820 is to revert automatically to receive mode after the ABM is transmitted. If parameter 66 is selected also, the Model 820 will automatically return to an idle mode upon completion of the ABM transmission.

- 72 — *Enable print of ABM* causes the contents of the ABM to be printed when the ABM message is transmitted and local copy is enabled, when the *HERE IS* key is actuated and the terminal is off line, or as a part of a local configuration report.

2.9.7 TERMINAL CONTROL (81-89, 91-93). The terminal control parameters enable use of certain special features of the Model 820. Note that any number of the terminal control parameters may be enabled at any time.

- 81 — *Enable device and format control from the communications line* allows the acceptance of format commands from a host unit. Sequences of this type consist of the character ESC plus a series of characters in the form shown in section 3.5.1.

NOTE

This parameter can be enabled only if the Device/Forms control option is installed in the terminal.

- 82 — *Enable local copy of transmitted data* causes all transmitted characters, except *ENQ* and *ESC*, to be copied to the Model 820. Local copy may be enabled for any communications mode.
- 83 — *Transmit DC3 or BREAK on printer busy and DC1 or LTA when ready*, when enabled, causes transmission of a **busy** signal when the *receive FIFO* is within 256 characters of being full and a transmission of a **ready** signal when the receive FIFO contains less than 1024 characters. The *busy/ready* response is determined by the communications mode as follows:
- *Full-duplex console and current loop (13-16):*
Busy - DC3 transmitted
Ready - DC1 transmitted
 - *Half-duplex (11):*
No response possible
 - *Half-duplex with reverse channel (12):*
Reverse channel OFF at *busy*; if the carrier is still being received and no line turnaround character has been received at *ready*, reverse channel is switched ON and operation continues. If the carrier has switched OFF before *ready*, RTS is switched ON; at *ready* or when reverse channel comes ON (whichever comes later), the first programmed line turnaround is transmitted, and RTS is switched OFF.

The status of configuration parameter 83 has no effect on the *ready/busy* signal provided on the reverse channel in the transmission modes selected by parameters 14, 15, and 16. Similarly, parameters 14, 15, and 16 have no effect upon the operation of parameter 83.

- 84 — *Do new line on receipt of LF* causes the terminal to respond to the receipt of the LF character by performing a carriage return *and* a line feed.
- 85 — *Do new line on receipt of CR* causes the terminal to respond to the receipt of the CR character by performing a carriage return *and* line feed.

- 86** — *Transmit CR LF when RETURN is entered* causes the terminal to transmit the CR and LF character sequence when CR is transmitted. (Model 820 KSR only)

NOTE

Simultaneous enabling of parameter 84 or parameter 85 with parameter 86 will cause double line feeds on data transmitted with local copy enabled. Also, see parameter 67 for combinations with that parameter.

- 87** — *Print all control characters* causes all control characters to be printed (using the character font shown in Appendix A) to enable analysis of incoming data streams. The control functions normally associated with these characters, including printer control functions, will not be performed.

- 88** — *Set compressed print only* provides a means of locking the printer in compressed print mode to prevent inadvertent changes of horizontal pitch which could result in printing beyond the right edge of the form.

NOTE

The optional compressed print feature must be installed to use this parameter. Use of the compressed print parameter without the option will not be allowed by the Model 820 Terminals.

- 89** — *Set absolute right margin at column 80* prevents inadvertent printing beyond the right edge of the form when the Model 820 KSR or RO is used in a network of 80-column format terminals.

- 91** — *Set 8 lines per inch spacing* locks the spacing between lines of print in the Model 820 KSR and RO terminals to 8 lines per inch.

- 92** — *Enable Automatic Perforation Skip* provides for a 3-line spacing around the perforation section of forms by setting the top margin of each form at line 3 and the bottom margin one line above the bottom of the form.

- 93** — *Set absolute line length at 8 inches* provides for 80 column 10 CPI printing and 132 column 16.5 printing

2.9.8 PROGRAMMABLE PARAMETERS (ABM, LTA, ENTER). In addition to the previously described operating parameters, the Model 820 KSR offers three programmable parameters - the *answer-back memory* (ABM), the *line turnaround characters* (LTA), and the *ENTER* key (if the optional numeric keypad is installed). All three parameters may be programmed from the keyboard as required. The Model 820 RO offers only the ABM and LTA programmable features. They may be programmed from the operator's keypad as required.

- *Answer-Back Memory* — The ABM is a unique terminal identifier which may be programmed from one to 21 characters long. Any combination of the 128 ASCII characters may be programmed in the ABM message.
- *Line Turnaround Characters* — The LTA characters provide control of the communications line when either half-duplex (parameter 11) or half duplex with reverse channel (parameter 12) is used. At least one and no more than three of the 128 ASCII characters must be programmed when either of the half-duplex communications modes are selected and no-LTA operation is *not* selected.

- *ENTER Key (KSR only)* — The ENTER key on the optional numeric keypad may be programmed to generate a 1, 2, or 3 character sequence when the ENTER key is actuated. Any combination of the 128 ASCII characters may be used.

2.9.9 CONFIGURATION REPORT. A printed configuration report may be obtained as follows:

2.9.9.1 LOCAL MODE or STANDBY MODE (KSR)

- Ensure that the LINE/●/LCL switch is not in the LINE position and that the CONFIGURE/OPERATE switch is in the OPERATE position.
- Initiate the configuration report by pressing and holding the **CTRL** and **SHIFT** keys and then momentarily pressing the **3** key; then release all keys.
- Observe that a report of the form

 NN;NN; . . . NNT

is printed. The terms *NN* correspond to the two-digit configuration codes which are currently active; i.e., the *enabled* parameters. The term *T* corresponds to the programmed line turnaround characters. If parameter 72 is enabled, the programmed ABM message will be included in the configuration report (on the next line).

NOTE

The codes 60, 70, and 80 are never reported and the ENTER key contents are not included in this report.

2.9.9.2 LOCAL MODE or STANDBY MODE (RO)

- Ensure that the LINE/●/LCL switch is not in the LINE position and that the terminal is not in CONFIGURE mode. If the terminal is in CONFIGURE mode, a **□ XX** will be in the terminal status display, where *XX* refers to one of the enabled configuration parameters. Press the **OPER** key on the operator's keypad to return the Model 820 to OPERATE mode. The line or column number (depending on the existence and status of optional DFC operating parameters) will now be displayed.
- Depress the **TEST** key and the **3** key in sequence. This will initiate the printing of the configuration report.
- Observe that a report of the form

 NN;NN; . . . NNT

is printed. The terms *NN* correspond to the two-digit configuration codes which are currently active; i.e., the *enabled* parameters. The term *T* corresponds to the programmed line turnaround characters. If parameter 72 is enabled, the programmed ABM message will be included in the configuration report (on the next line).

NOTE

The codes 60, 70, and 80 are never reported.

2.9.9.3 LINE Mode (DFC option only) KSR and RO. It is possible to determine the configuration parameters of a Model 820 KSR or RO in an online, active condition if and only if it is equipped with the DFC option. A configuration report may be transmitted to the host system in the following manner:

- a. Establish communications with the Model 820 KSR or RO. This entails knowing at least the duplex mode, baud rate, and parity configurations of the Model 820.
- b. Transmit the following sequence to the Model 820 KSR or RO:

ESC [c

- c. The Model 820 KSR or RO will transmit (as soon as it attains control of the line, in half-duplex mode) the following sequence:

ESC [820; NN; NN; NN; . . . NNcT

The terms *NN* correspond to the two-digit configuration codes which are currently active; i.e., the *enabled* parameters. The term *T* corresponds to the first programmed line turnaround character.

NOTE

The codes 60, 70, and 80 are never reported and the full LTA, ABM, and ENTER key contents (if KSR) are not included in this report.

2.10 CONFIGURATION PARAMETER ENTRY

The selected configuration parameters are entered via the keyboard of the Model 820 KSR or the operator's keypad of the Model 820 RO. This procedure, called *configuring* the terminal, is outlined in the following paragraphs in the recommended sequence.

2.10.1 INITIATE CONFIGURATION. To initiate configuration, proceed as follows:

- a. Set the LINE/●/LCL switch to the LCL position (lower edge depressed).
- b. For the Model 820 KSR, lift the terminal cover and set the CONFIGURE/OPERATE switch to the CONFIGURE position (toward the front of the terminal). For the Model 820 RO, lift the operator's keypad cover and depress the **CNFG** key.
- c. Close the terminal cover (KSR).
- d. Observe the terminal status display: The left digit is the symbol □, indicating that the terminal is in the *configure mode*; the center and right digits represent the configuration code corresponding to the first enabled configuration parameter.

2.10.2 REVIEW CURRENT CONFIGURATION. The current configuration (i.e., all enabled parameters) can be *reviewed* by using the TAB key. Each time the TAB key is pressed and released, the Model 820 KSR or RO will display the next enabled configuration parameter (the *next parameter* is the one with the next higher configuration code or the lowest configuration code if none higher are enabled). Use of the TAB key in no way affects the current configuration.

2.10.3 ENABLE MUTUALLY EXCLUSIVE PARAMETERS. *Mutually exclusive parameters* are those which *must* be specified. The mutually exclusive parameters are

- Communications mode *codes* 11-16
- Communications rate *codes* 21-29
- Parity *codes* 31-38 (or 39 for the RO only)

To enable a new mutually exclusive parameter proceed as follows:

- a. Type the two-digit code corresponding to the parameter to be enabled (see Table 2-1 for a list of configuration parameter codes, or refer to the *Operator Reference Cards*).
- b. Momentarily press the **RETURN** key (the **CR** key of the Model 820 RO)
- c. Listen for a short audible tone and ascertain that the code for the new parameter is displayed, signifying that the old parameter has been *replaced* with the new.

2.10.4 ENABLE ON/OFF PARAMETERS. The ON/OFF parameters are those which modify the operation of the terminal and are not required. Any number of the ON/OFF parameters may be enabled (or switched ON). The ON/OFF parameters are:

- The line control options, *codes* 61-67
- The transmission control (ABM) options, *codes* 71 and 72
- The terminal control options, *codes* 81-89, and *codes* 91-93.

To enable a new ON/OFF parameter proceed as follows:

- a. Type the two-digit code corresponding to the parameter to be enabled.
- b. Momentarily press the **RETURN** key (the **CR** key of the RO).
- c. Listen for a short audible tone and ascertain that the code for the new parameter is displayed, signifying that the new parameter is enabled. Note that no other parameter is affected.

2.10.5 DISABLE ON/OFF PARAMETERS. Any ON/OFF parameter that is currently enabled may be disabled (or switched OFF). To disable an ON/OFF parameter proceed as follows:

- a. Type the two-digit code corresponding to the parameter to be disabled *or* press the **TAB** key until the code is displayed.
- b. Momentarily press the **DEL** (delete) key.
- c. Listen for a short audible tone and ascertain that the code for the next enabled parameter is displayed, signifying that the old parameter is disabled.

2.10.6 PROGRAM THE ABM, LTA, AND ENTER KEY. The programmable parameters are entered from the keyboard/keypad while in the CONFIGURE mode. To program the LTA, ABM, or ENTER key proceed as follows:

- a. Type the code corresponding to the programmable characters as follows:

- 60** — line turnaround (LTA) characters
- 70** — answer-back memory (ABM)
- 80** — ENTER key (optional numeric keypad must be installed; Model 820 KSR only).

- b. Momentarily press the **RETURN** key (the **CR** key on the Model 820 RO).
- c. Observe that the left digit of the TSD displays \angle , signifying that the terminal is in the *programming mode*, and that the other two digits display $\angle\angle$, signifying that the first character of the programming sequence may now be entered.
- d. KSR: Type any of the 128 ASCII characters. RO: Input the HEX code for any of the 128 ASCII characters. This is a two digit code found in the operator reference cards. For each entry the count in the middle and right digits will increment by one, signifying that the entry has been accepted. The maximum number of characters which may be entered is three for the LTA, 21 for the ABM, and three for the ENTER key. (KSR only)
- e. Terminate the programming sequence by (1) entering the maximum number of characters or (2) pressing the **HERE IS** key. There is no **HERE IS** key on the Model 820 RO, so the **END** key is used for this function.
- f. Listen for a short audible tone and ascertain that the left digit displays \angle and the other two digits display the code for the next enabled parameter, signifying that the programming sequence has been successfully completed.

NOTE

The key sequence **60** (or **70** or **80**), **RETURN, HERE IS** (60 or 70 CR END for RO) may be used to erase the corresponding programmable parameter.

2.10.7 CONFIGURATION ERRORS. Typing errors may be made during the configuration process. If an invalid code is entered via the keyboard, the terminal will emit a long audible tone and display the code $\angle\angle\angle$. To recover from this condition, type the correct code (or press the TAB key) and continue the configuration procedure. Note that no parameters are changed when a configuration error occurs.

2.10.8 TERMINATE CONFIGURATION. Before terminating the configuration mode, it is advisable to review the current configuration by pressing the TAB key to verify that the correct parameters are enabled. To terminate the configuration mode proceed as follows:

- a. Lift the terminal cover (KSR only).
- b. Set the CONFIGURE/OPERATE switch in the OPERATE position (toward the rear of the terminal) on the Model 820 KSR, or depress the **OPER** switch on the Model 820 RO operator's keypad.
- c. Close the cover (KSR) or the operator's keypad cover (RO).
- d. Observe that the TSD displays the column number signifying that the terminal has calculated a checksum for the current configuration parameters and has stored the parameters and checksum in nonvolatile memory.

2.11 COMMUNICATIONS INTERFACE CABLE CONNECTION

The Model 820 has available as an accessory a 1.8 meter (6 foot) communications interface cable (TI part number 0993205-0001) suitable for direct connection to Bell System type 103, 113, 202, and 212 data sets. To install the cable between the terminal and the data set, simply plug the cable into the appropriate

receptacles and tighten the mounting screws. Other cable options are available for use with the Model 820; refer to Appendix G for communications interface cabling information.

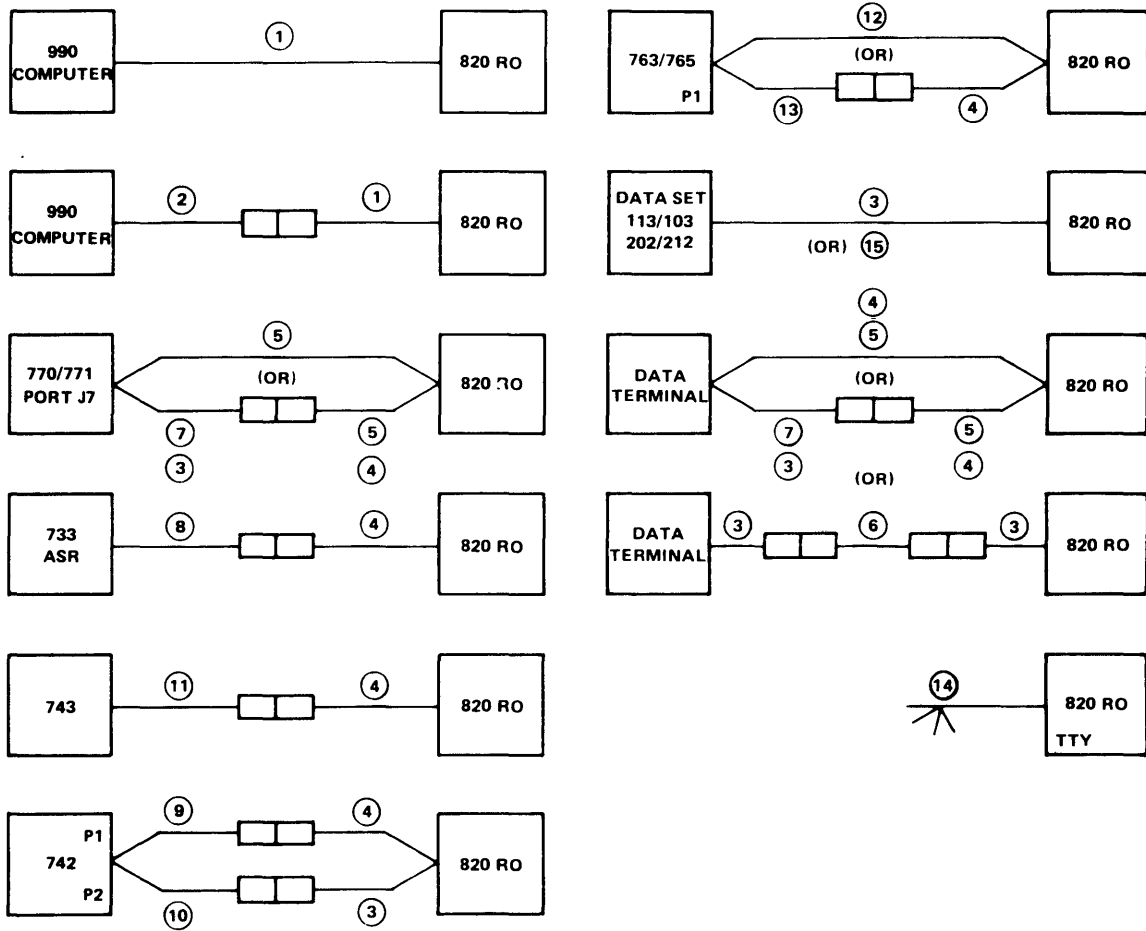

Item	Part Number	Description	820 RO Connector Type	Device Connector Type	Length	
					Meters	Feet
1	2262093-0001	990 TTY/EIA To 820 Cable	25 Pin Male	25 Pin Male	9.1	30
2	2262094-0001	990 Extension - 820 Cable	25 Pin Male	25 Pin Female	1.8	6
3	993205-0001	113A/103/202/212 Data Set	25 Pin Male	25 Pin Male	1.8	6
4	993210-0001	Data Terminal Cable	25 Pin Male	25 Pin Female	1.8	6
5	993239-0001	770 Data Terminal Cable	25 Pin Male	25 Pin Male	1.8	6
6	2263351-0001	Terminal Adapter Cable	25 Pin Female	25 Pin Female	1.8	6
7	993211-0001	EIA Extension Cable (25 wires)	25 Pin Male	25 Pin Female	1.8	6
8	959372-0002	733 EIA Cable	25 Pin Male	25 Pin Edge	1.8	6
9	969626-0001	742 EIA Cable	25 Pin Male	10 Pin Dual		
10	973265-0001	742 Auxiliary Cable	25 Pin Female	Edge Connector		
				15 Pin Dual	1.8	6
11	983848-0001	743 EIA Cable	25 Pin Male	Edge Connector	3.7	12
				15 Pin Female	1.8	6
12	2263350-0001	763/765 Data Terminal Cable	25 Pin Male	15 Pin Female	1.8	6
13	2200051-0001	763/765 Data Set Cable	25 Pin Male	15 Pin Female	1.8	6
14	994403-0001	TTY Current Loop Cable	—	—	1.8	6
15	2207634-0001	Asynch/Synch EIA Cable	25 Pin Male	25 Pin Male	1.8	6

Figure 2-9. Communications Interface Cable Connections

SECTION III OPERATION

3.1 INTRODUCTION

This section provides a complete functional description of the Model 820 Terminals, including the use of all controls and indicators. Figure 3-1 shows the location of the major functional components of the terminals including the *operator's panel*, the *printer*, the *communications interface*, and the *operator reference cards*. Also discussed in this section is the operation of the various terminal *options*.

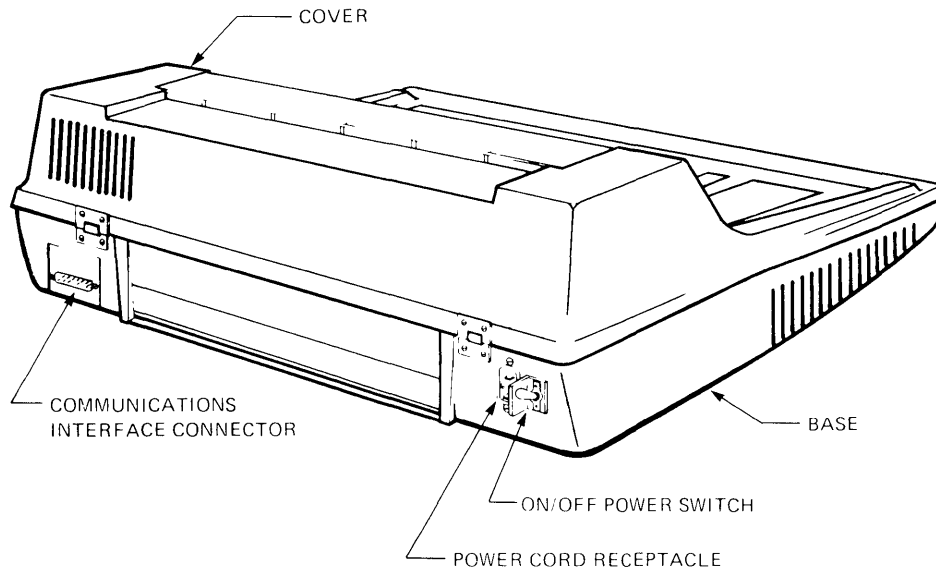

(a) REAR view, Model 820 KSR and RO

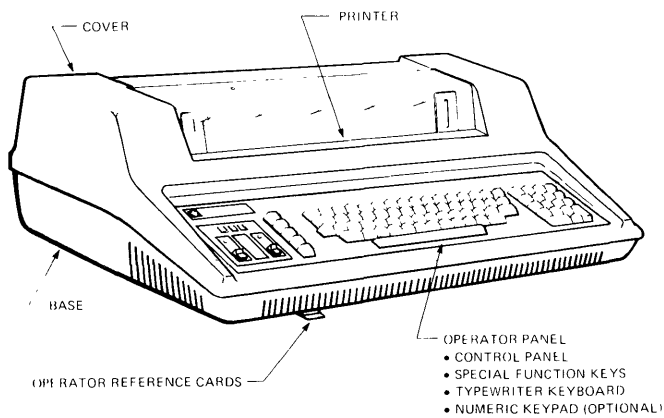

(b) Model 820 KSR data terminal

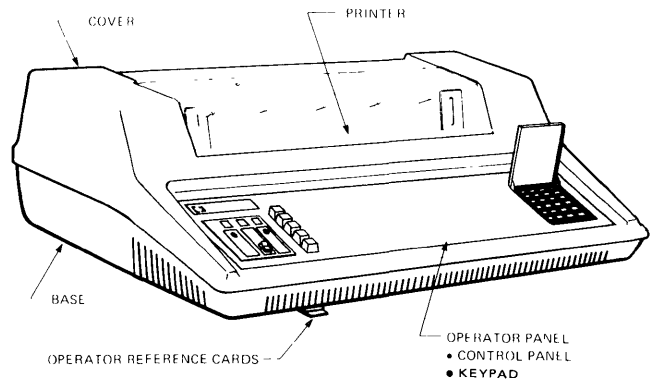

(c) Model 820 RO data terminal

Figure 3-1. Model 820 KSR and RO Major Functional Components

3.2 OPERATOR'S PANEL

The operator's panel of the Model 820 KSR, shown in Figure 3-2, may be considered as four sections: the *control panel*, the *typewriter keyboard*, the optional *numeric keypad*, and the *CONFIGURE/OPERATE switch*. The operator's panel of the Model 820 RO, shown in Figure 3-3, may be considered as two sections: the *control panel* and the *operator's keypad*. The operation of each section on the operator's panel of the Model 820 terminals is described in the following paragraphs.

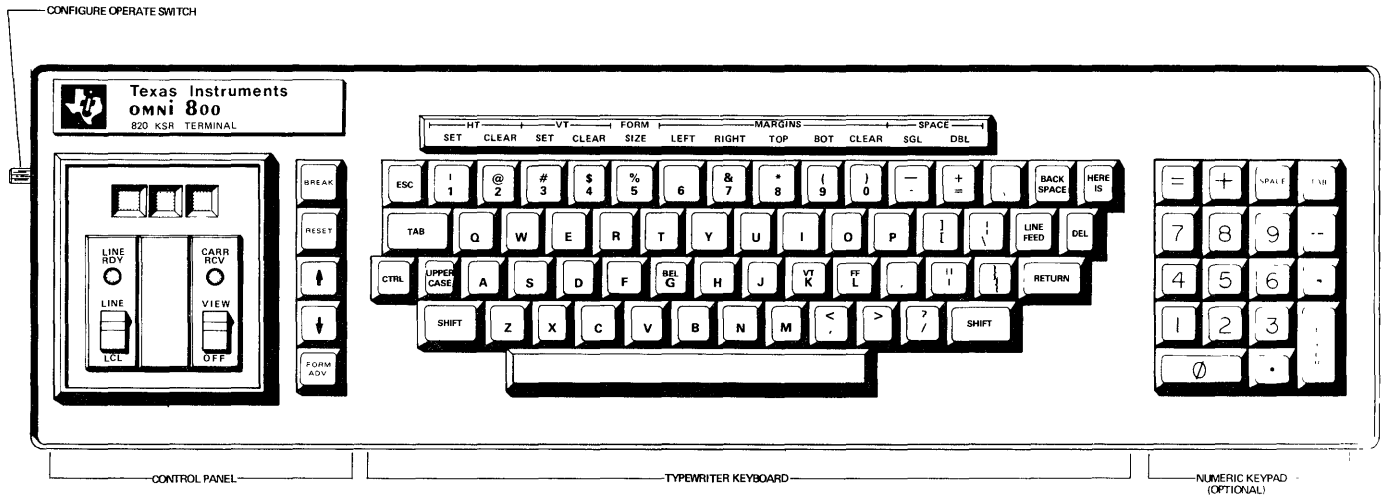

Figure 3-2. The Operators Panel, Model 820 KSR

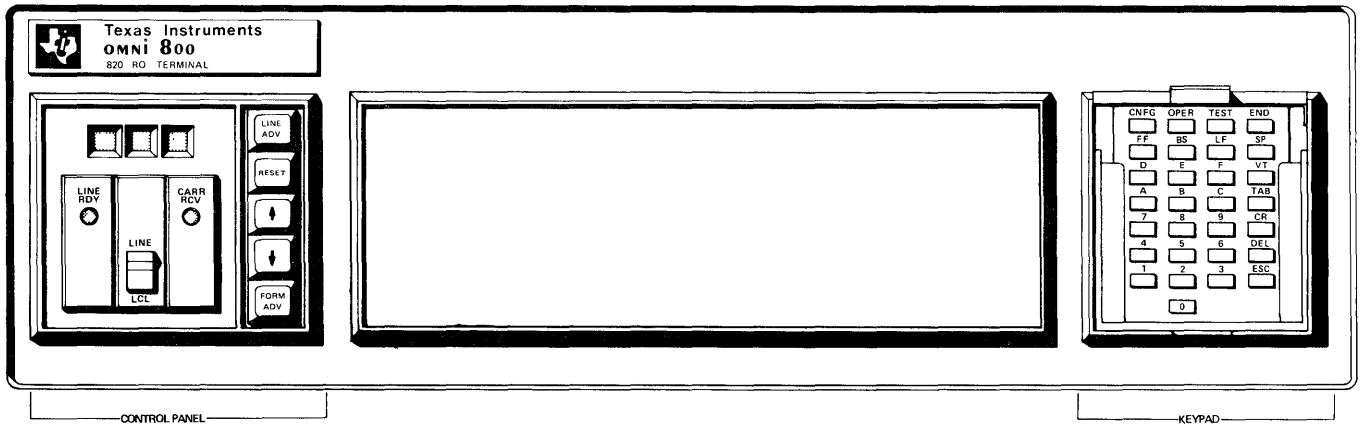

Figure 3-3. The Operators Panel, Model 820 RO

3.2.1 CONTROL PANEL. The control panel provides various switches to permit the operator to control the communications interface and the operation of the printer. Various indicators provide operating status information to the operator.

3.2.1.1 LINE/•/LCL Switch. This three-position rocker switch controls the communications interface as follows:

- LINE — When the switch is set to LINE, the terminal is in the *LINE* mode (or on-line) and data may be interchanged with other devices in the system. Data received from the host system via the communications interface is printed, and data entered on the Model 820 KSR keyboard by the operator is transmitted to the host system via the communications interface. ABM messages and terminal reports from the Model 820 KSR and RO terminals are transmitted only in this mode.
- (STANDBY) — When the switch is in the center position, the terminal is in the *STANDBY* mode and no data may be interchanged with the host system. Data received from the host system via the communications interface is ignored. Data entered on the Model 820 KSR keyboard or RO operator's keypad by the operator is printed but not transmitted. When in the *STANDBY* mode, the Model 820 will maintain connection to the host system (similar to a telephone on "hold"), if a connection has already been established.
- LCL (LOCAL) — When the switch is set to LCL, the terminal is in the *LOCAL* mode and no data may be interchanged with the host system. Operation in the *LOCAL* mode is identical to the *STANDBY* mode, except that connection to the host system is not maintained.

3.2.1.2 VIEW/OFF Switch (Model 820 KSR only). This two-position rocker switch controls the *last character visibility* feature of the Model 820 KSR. When set to the VIEW position, the printhead will move to the right to make visible the last character printed. A pointer on the left side of the printhead indicates the position where the next character will be printed. While the switch is in the VIEW position, the receipt of any printable character will cause the printhead to return to its previous position to print that character; after the character is printed, the printhead will again move to the right if no more characters are received within 1 second.

When the switch is placed in the OFF position, the printhead will return to its previous position to print the next character and will not move to the right to permit visibility of the last character.

NOTES

- (a) The pointer affixed to the printhead is accurate *only* when the printhead has moved to the right to allow last character visibility.
- (b) The Model 820 RO Terminal has an automatic view function to provide last character visibility. It has no VIEW/OFF switch, but performs normally as does the Model 820 KSR with the switch in the VIEW position.

3.2.1.3 LINE RDY and CARR RCV Indicators. These two light-emitting-diode (LED) indicators provide operating status information for the communications interface. The LINE RDY (line ready) indicator shows the status of the data set ready (DSR) interface signal and the transmit circuitry; the CARR RCV (carrier received) indicator shows the status of the data carrier detect (DCD) interface signal. Table 3-1 defines the operation of these two indicators.

Table 3-1. LINE RDY and CARR RCV Indicators

COMMUNICATION MODE	CARR RCV INDICATOR		LINE RDY INDICATOR		
	ON	OFF	FLASHING	ON	OFF
Half Duplex	Ready to Receive	Receive not ready; transmit available	In standby or transmit requested but not ready	Comm line ready	Comm line not ready
Full Duplex		Receive not ready; no carrier	In standby or data set failure		

3.2.1.4 Terminal Status Display (TSD). This three-digit numeric display provides several operating indications, including *next character position*, *current line number*, *status*, and *configuration and programming modes*. Table 3-2 summarizes the TSD functions.

- *Next Character Position* — The TSD normally displays the next character position; that is, if a character was just printed in column 67, the TSD will display 67. When indicating the next character position, the display will always show a number between 001 and 133 (001 and 219 for machines equipped with the compressed print option).
- *Current Line Number* — If the device/forms control option is installed in your Model 820, the TSD can be converted from a next-character-position indicator to a current-line-number indicator. When used as a current-line-number indicator, the left digit of the TSD will be blank and the other two digits will contain the line number, if less than 100. Since it is possible to have line numbers greater than 100 (with the 8 LPI configuration), the line numbers 100-112 will appear in the TSD identical to column numbers.
- *Status* — The TSD functions as a status indicator when an error condition or a special operating condition exists. When operating as a status indicator, the TSD will flash on and off, the left digit will contain the symbol \square , and the other two digits will display one of the status codes listed in Table 3-3.

The status codes are prioritized in ascending numeric order; that is, code 00 is assigned the highest priority and 39, the lowest. When multiple status codes are active, the highest priority code (i.e., the lowest number) will be displayed until it is cleared by pressing RESET; then the next highest code will be displayed.

- *Configuration and Programming Modes.* Use of the TSD, in conjunction with the configuration and programming modes, is explained in paragraph 2.10. In summary, a \square displayed in the left digit indicates the configuration mode, and a \square displayed in the left digit indicates the programming mode.

Table 3-2. Interpreting Terminal Status Display (TSD) Functions

a. Print Column/Current Line Indicator

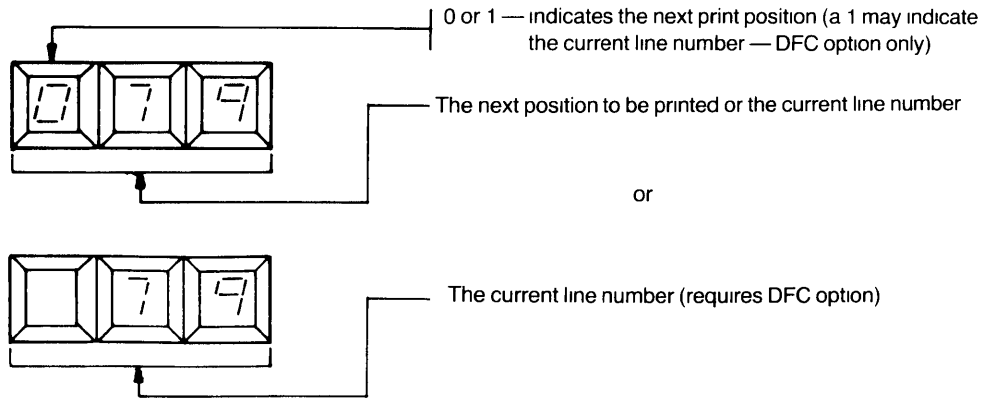

b. Status (Display Flashing)

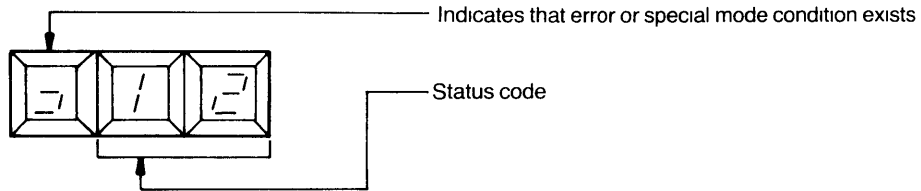

c. Configure Mode

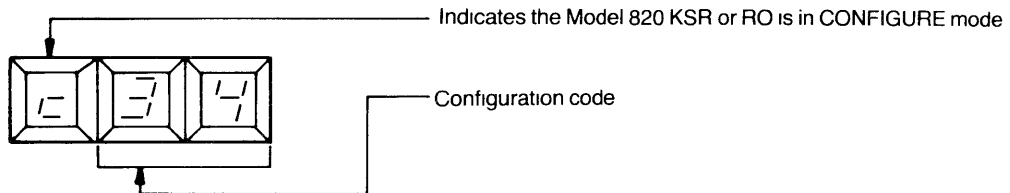

d. Program Answer-Back Memory (ABM), Line Turnaround (LTA) Character(s), or ENTER Key Sequence (ENTER key present only on Model 820 KSR Models w/optional numeric pad.)

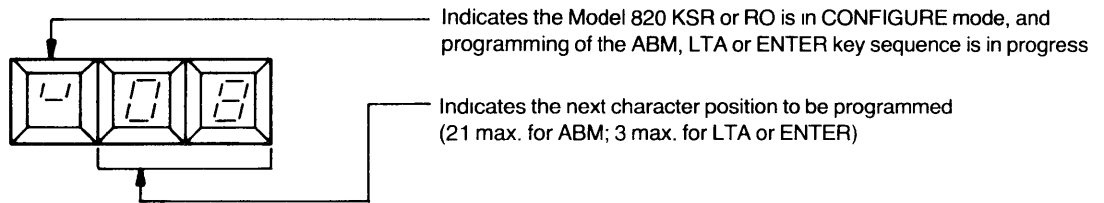

e. Indicator Test

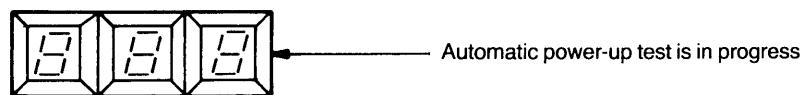

Table 3-3. Status Codes

TYPE	CODE	DEFINITION	ACTION REQUIRED
I	00 01 02 03	Memory Failure RAM memory ROM memory I ROM memory II Nonvolatile memory	Equipment problem: Cycle power. If condition repeats, call for service.
II	10 11 12	Operator Correctable Leaving configure mode with half-duplex set, but no LTA specified Carriage jam Paper-out	Go to CONFIGURE mode and specify LTA character or set full-duplex operation. Clear jam and reset Load paper and reset
III	20 21 22 23 24 25 26 29††	Abnormal Communications Clear-to-send timeout Loss-of-carrier timeout Wrong number timeout Receive Buffer overflow Parity error Transmit buffer overflow No activity timeout Invalid EXC sequence from communications line	Reset* Reset* Reset* Reset † Reset/Change Parity† Reset† Reset* †
IV	30 31 39	Special Operating Mode Keyboard locked Printer off Test in progress	From line or reset From line or reset Reset
V		Operator Error Invalid ESC sequence Invalid ESC sequence from keyboard	Reset and type valid command Reset and type valid command sequence

* Automatically reset when data-set-ready comes on (repetition could indicate data set failure), associated with failsafe disconnect parameter (except code 26)

† Automatically reset when status report transmitted per request from line: See DFC Option

†† This code is not displayed, but it is transmitted as part of the status report. See DFC Option

3.2.1.5 Special Function Keys. The five momentary pushbuttons located on the control panel provide additional control of the printer and the communications interface.

- **RESET.** The RESET pushbutton enables the operator to acknowledge and clear errors detected by the terminal and to return the terminal to normal operation after a self-test has been initiated (see Section V of this manual for self-test instructions).
- **↑ and ↓.** These pushbuttons permit the operator to make fine adjustments to the vertical paper registration. The ↑ key advances the paper in 0.5 mm (1/48 inch) steps; the ↓ key performs the reverse function.
- **FORM ADV.** This pushbutton permits the operator to advance the paper without generating or receiving a printer control code. If FORM ADV is pressed and released, the paper will advance one line and the printhead will remain in its present position. If FORM ADV is pressed and held (for longer than 0.25 second), the paper will advance to the top of the next form and the printhead will perform a carriage return.
- **BREAK (Model 820 KSR only).** The BREAK pushbutton enables the operator to signal the host system that an abnormal condition exists. When the BREAK key is pressed, the terminal generates a *break* signal for 256 milliseconds or until the key is released, whichever is longer. When the terminal is transmitting, the *break* signal is a SPACE condition on the transmitted data line; when the terminal is configured for half-duplex with reverse channel (parameter 12) and is receiving, the *break* signal is the switching of the reverse channel to the OFF condition.

- **LINE ADV (Model 820 RO only).** The LINE ADV performs the same function as a short depression of the FORM ADV key of the KSR or the RO, i.e., it advances the paper by one line at the configured line spacing conditions.

3.2.2 TYPEWRITER KEYBOARD (Model 820 KSR Only). The typewriter keyboard is capable of generating all 128 ASCII characters defined in Appendix B to this manual. The keyboard features n-key rollover interlocking to prevent erroneous code generation when two or more keys are pressed simultaneously. All keys on the keyboard except SHIFT, UPPER CASE, CTRL, and HERE IS generate a single character code when pressed. Depending upon the configuration of the terminal, the RETURN key may generate more than one character code per depression.

3.2.2.1 Code Generating Keys. All code generating keys except ESC, TAB, DEL, and RETURN feature automatic-character-repeat operation; that is, when a key is pressed for longer than 0.6 seconds, the associated character is generated at a 10 character per second rate until the key is released.

The code generated for a particular key is dependent upon the position of the four qualifier keys, SHIFT (2 keys), UPPER CASE, and CTRL, as follows:

- **SHIFT** — When this key is depressed while another key is pressed, uppercase alphabet characters A-Z are generated, and the top function marked on two-function keys is generated (e.g., SHIFT and !/1 generates !).
- **UPPER CASE** — When this alternate action switch is locked down, uppercase alphabet characters A-Z are generated. This switch affects only the alphabet keys.
- **CTRL** — When this key is depressed in conjunction with another key, ASCII control characters are generated. Appendix B illustrates the control characters generated by each key.

3.2.2.2 HERE IS Key. When pressed, the HERE IS key causes the Model 820 KSR to transmit the answer-back memory (ABM) message if the ABM is programmed; HERE IS is ignored if the ABM is not programmed. Note that if the LINE/•/LCL switch is in the LCL position and parameter 72 is enabled, the ABM will be printed. Control characters in the ABM will be printed in the font shown in Appendix A.

3.2.2.3 Numeric Keypad Option. The numeric keypad option provides an additional 18-key cluster for use in high-volume number entry applications. The user-programmable ENTER key can generate a 1, 2, or 3-character sequence when pressed (see paragraph 2.10.6).

3.2.3 OPERATOR'S KEYPAD (Model 820 RO Only). The operator's keypad is capable of generating the ASCII codes for 0-9 and A-F, plus the ASCII control character codes FF, BS, LF, SP, VT, HT (tab), CR, DEL, and ESC. Keys are print-generating only in local or standby mode; if parameter 87 is enabled, the fonts shown in Figure A-2 of Appendix A will be produced for the control characters. The keystroke codes generated from the operators keypad cannot be transmitted. The process of programming the answerback memory message (ABM) and LTA characters is explained in Section 2.10.

In addition to the code generating keys, there are four keys on the operator's keypad which are used for configuring and testing the Model 820 RO, yet do not generate ASCII codes. They are:

- **CNFG.** The configure key causes the Model 820 to enter the configure mode if the machine is in LCL mode. The machine will show a \square in the leftmost digit of the TSD and will accept keystrokes from the keypad as configuration data. See Section 2.10 for instructions on configuring the terminal.

- **OPER.** The operate key causes the machine to leave configure mode and return to its normal operating state.
- **TEST.** The test key is used to initiate several maintenance tests and reports from the LCL mode. A description of these tests is given in Section 5.4 of this manual.
- **END.** The end key is used in programming LTA characters and the ABM messages much the same way as the HERE IS key on the KSR keyboard. This keystroke ends the LTA or ABM programming process at the point of its depression.

NOTE

Since initiation and end of the configuration sequence is handled by the operator's keypad, there is no need for a CONFIGURE/OPERATE switch on the Model 820 RO. Thus, the following section pertains to the Model 820 KSR only.

3.2.4 CONFIGURE/OPERATE SWITCH (Model 820 KSR only). This two-position slide switch is located on the left side of the operator panel under the terminal cover. When in the CONFIGURE position, the terminal operating parameters may be changed; when in the OPERATE position, the terminal functions normally. The OPERATE position of this switch is shown in Figure 3-4.

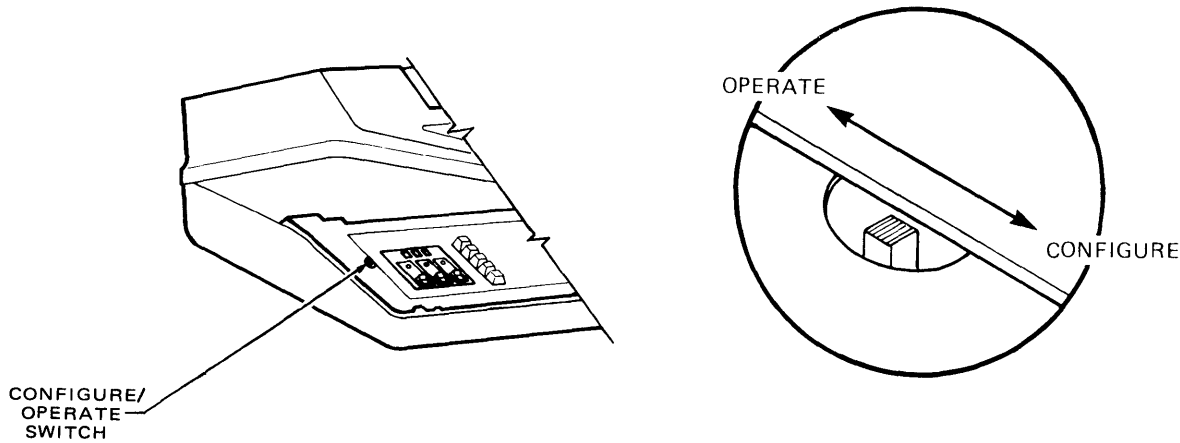

Figure 3-4. CONFIGURE/OPERATE Switch

NOTE

Before the CONFIGURE/OPERATE switch is set to the CONFIGURE position, the LINE/●/LCL switch must be set to the LCL position. If this condition is violated, the terminal will pulse the audible tone on and off until the above switch settings are made.

3.2.5 AUDIBLE TONE. The Model 820 Terminals contain an audible tone generator which produces a 3200 Hz (± 500 Hz) signal at a sound pressure of 55 ± 10 dB measured approximately 610 mm (2.0 feet) directly in front of the terminal. The operation of the audible tone is summarized in Table 3-4.

Table 3-4. Audible Tone Operation

SIGNAL	EXPLANATION
Short Tone (80 milliseconds)	1. 8 character positions from right margin when typing OR 2. ASCII BEL character has been received OR 3. A configuration command has been accepted OR 4. Power-up test has been completed successfully
Repeated Short Tones	Invalid attempt to initiate or terminate CONFIGURE mode operation
Long Tone (1 second)	A new status code has been activated or an invalid configuration parameter entered.

3.3 PRINTER

The printer is a serial, wire-matrix, impact mechanism which prints on conventional continuous-forms paper. Print speed is a nominal 150 characters per second.

3.3.1 CHARACTER SET AND FONT. The 94 graphic symbols defined by ASCII plus a unique parity error symbol are printed in a nine-wide by seven-high matrix font as shown in Appendix A. When the 33 control characters are to be printed rather than acted upon (i.e., parameter 87 enabled), they are printed in the control symbol font shown in Appendix A.

3.3.2 FORMAT PARAMETERS. To facilitate setting up the Model 820 KSR as a *forms printer*, the following *format parameters* are defined:

- Form Length* — The number of lines on a page.
- Top-of-form* — The first line on a page
- Bottom-of-form* — The last line on a page
- Top margin* — The first line which may be printed on a page
- Bottom margin* — The last line which may be printed on a page
- Left margin* — The first print position on a line
- Right margin* — The last print position on a line.

These format parameters are shown graphically in Figure 3-5.

3.3.3 END-OF-LINE ALARM. The audible tone sounds momentarily when the printhead reaches the eighth print position before the right margin. The tone functions only on keyboard- or keypad-entered data and is silenced on received data.

3.3.4 PRINTER OPERATION. The printer is controlled by the data received either from the communications interface or from the keyboard/keypad. Two types of data may be received: *printable characters* and *control characters*.

3.3.4.1 Printable Characters. The receipt of printable characters causes those characters to be printed in the sequence received. Up to 132 characters can be printed on a single line (218 if the Model 820 Terminal is equipped and configured to use the compressed print option).

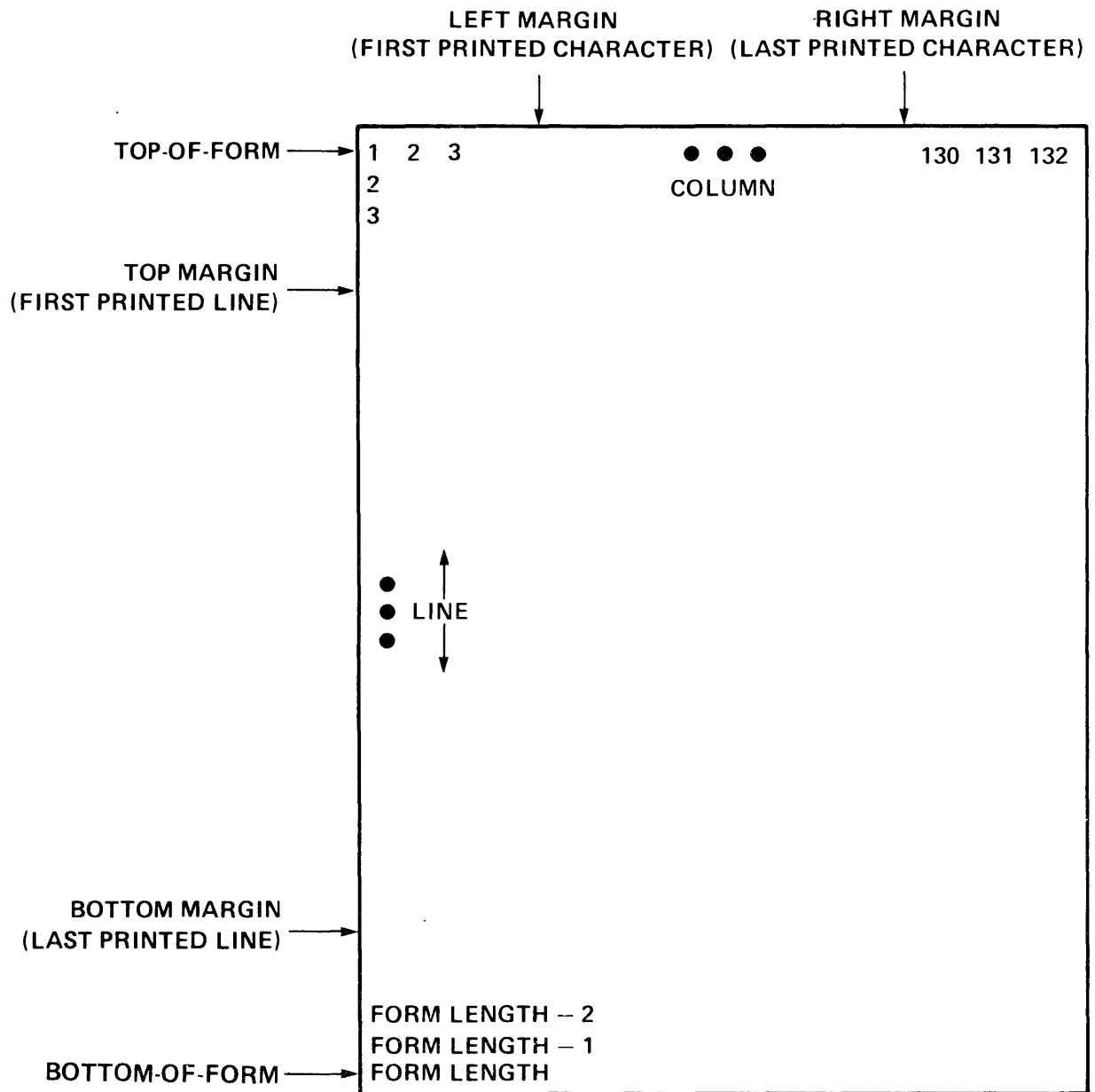

TOP OF FORM = LINE 1

$1 \leq \text{FORM LENGTH} \leq 84$ at 6 LPI or 112 at 8 LPI

$1 \leq \text{TOP MARGIN} \leq \text{BOTTOM MARGIN} \leq \text{FORM LENGTH}$

$1 \leq \text{LEFT MARGIN} \leq \text{RIGHT MARGIN} \leq 132$ at 10 CPI or 218 at 16.5 CPI

Figure 3-5. Format Parameters

3.3.4.2 Automatic New Line. After a character is printed in the column position defined as the *right margin*, the terminal will automatically print the next character in the column position defined as the *left margin* of the *next line*. This feature is called *automatic new line*.

3.3.4.3 Control Characters. There are 33 control characters defined by ASCII. Although the Model 820 KSR is capable of generating and transmitting all 33 control characters, it responds only to those listed below. The Model 820 RO is capable of generating locally only those control characters listed in Section 3.2.3, it is capable of transmitting all 33 if any are included in the ABM message. However, any control characters received are handled similar to the KSR machine if they are listed below. Those not listed below are ignored (except when parameter 87 is enabled) in both the Model 820 KSR and RO Terminals.

- BS** Backspace — moves the printhead one character space to the left. BS is ignored if the printhead is at the left margin.
- CR** Carriage return — causes the next printable character to be printed in the character position defined as the left margin. CR also advances the paper one line space if the appropriate *new line* feature is configured (parameter 85 enabled).
- RETURN will cause CR and LF to be transmitted if the appropriate feature is configured (parameter 86 enabled, KSR only). RETURN will cause CR and the first LTA character to be transmitted if the appropriate parameters are enabled and disabled (11 or 12, 67, and not 66, KSR only)
- FF** Form feed — positions the printhead to the top-left margin of the next page.
- LF** Line feed — advances paper one line space. If LF advances paper beyond the bottom margin, the paper will advance to next top margin. LF also will cause a carriage return if the appropriate *new line* feature is configured (parameter 84 enabled).
- BEL** Bell — sounds the audible tone generator for 80 milliseconds.
- HT** Horizontal tab — if the Device/Forms Control (DFC) option is installed, HT advances the printhead to the next tab stop. With no tabs set between the present print position and the right margin, a horizontal tab is treated as a carriage return/line feed so that the next printable character will appear at the left margin of the next line. HT is ignored if the DFC option is not installed.
- SO** Shift out — selects an alternate character set, such as APL, for printing. SO is ignored if an alternate character set option is not installed.
- DC1** Device control 1 — is transmitted by the terminal to indicate *buffer ready* if parameter 83 a full duplex communications mode (13, 14, 15, or 16) is enabled. DC1 is ignored when received.
- DC3** Device control 3 — is transmitted automatically to indicate *buffer full* if parameter 83 and a full duplex communications mode (13, 14, 15, or 16) is enabled. DC3 is ignored when received.
- ENQ** Enquiry — receipt activates the answerback memory (ABM) if an ABM is programmed. In half-duplex operation transmission of ENQ or receipt of ENQ followed by loss of carrier initiates a line turnaround if, and only if, the ABM is programmed.
- EOT** End-of-transmission — used as a disconnect character if parameter 62 or 63 is enabled; otherwise, EOT is ignored.

- DLE** Data link escape — receipt of DLE followed by EOT initiates disconnect if parameter 63 is enabled; otherwise DLE is ignored.
- ESC** Escape — identifies the subsequent character or character sequence as a terminal command if the DFC option is installed. ESC is ignored if the DFC option is not installed.

3.3.5 SETTING THE TOP-OF-FORM. The top-of-form is established as follows:

3.3.5.1 Method 1 (Using ↑ and ↓)

- a. Press and hold the **FORM ADV** key for longer than 1/4 second to advance the paper and initialize the line count to one.
- b. Use the **↑** and **↓** keys as required to position the paper so that line one (the top-of-form) can be printed. (Do not use the **LINE FEED** key because the line count will be incorrect.)

NOTE

It may be easier to open the tractor flaps and move the paper to the approximate position required before using the **↑** and **↓** keys.

3.3.5.2 Method 2 (Using ESC)

- a. With the LINE/•/LCL switch in LOCAL or • (STANDBY) position, use the **LINE FEED** , **LF** , or **LINE ADV** key to move the paper to the desired top-of-form point.
- b. Press the **ESC** and **5** keys in sequence.
- c. Press the **CR** key (RO) or the **;** key (KSR).
- d. The top-of-form is now set; the terminal will respond with a short audible tone.

3.3.6 PAPER-OUT CONDITION. When the paper supply is exhausted, the terminal will cease printing, sound the audible tone, and display an error code. The remainder of the form currently being printed may be completed by pressing the RESET switch once for each line to be printed (if this is done, the error condition display will remain on). When the current form is completed, it may be ejected by depressing the FORM ADV switch (for longer than 1/4 second) and a new box of forms installed. Pressing the RESET pushbutton after loading new paper will clear the error condition.

3.3.7 MECHANISM FAILURE DETECTION. The control electronics constantly monitors a tachometer signal from the carriage drive motor and determines the response of the carriage to positioning commands. If a high friction condition or obstruction is detected, printing will be inhibited, the audible tone will sound, and a *mechanism failure* (carriage jam; code 11) code will be displayed by the TSD.

If the terminal has been configured to issue a BREAK signal or to disconnect when a paper-out condition occurs, the same action will be taken when a mechanism failure occurs.

3.3.8 DATA BUFFERING AND PRINTER THROUGHPUT. All data to be printed by the Model 820 KSR or RO is passed through a first-in-first-out buffer memory (FIFO) which has a maximum capacity of 1280 characters. The Model 820 monitors the number of characters stored in the FIFO and selects an appropriate print mode accordingly.

When only one or two characters are stored in the FIFO, as would occur during keyboard entry, the printer functions incrementally, printing one character at a time. Operation is unidirectional that is, characters are printed from left to right with a carriage return and line feed at the end of each line.

If the number of characters stored in the FIFO increases, as would occur when receiving continuous data from a 300-baud line, the printer switches to a continuous unidirectional mode. No fill characters are required after carriage return, line feed, or tab commands since the print speed is adequate to prevent overflowing the FIFO at data rates up to 300 baud.

If the number of stored characters increases to the point where more than one line is waiting in the FIFO to be printed, the printer switches to a high speed bidirectional mode. In this mode data is printed one line at a time. At the end of each line, the printhead is positioned to print the next line either forward or backward, whichever direction will require the lesser time.

In the bidirectional mode the printer will “keep up” with a continuous 1200-baud data stream without FIFO overflow, provided the data is formatted into lines of 29 characters or longer. Maximum throughput for full 132-column lines is 60 lines per minute.

The terminal may be configured (parameter 83 enabled) to transmit a *busy* signal when there is a danger of buffer overflow, followed by a *ready* signal when the printer overtakes the incoming data. *Busy* is transmitted when fewer than 256 vacant character spaces remain in the buffer, and *ready* is transmitted when the buffer contains more than 1024 vacant character spaces. If buffer overflow occurs, the audible tone will sound, and an error code will be displayed.

Busy and *ready* signals depend upon the communications mode, as explained in Section II.

3.4 COMMUNICATIONS INTERFACE

The communications interface provides the method by which the Model 820 Terminals interchange data with the host system.

3.4.1 INTERFACE SIGNALS. The communications interface signals conform to the electrical requirements of EIA Standard RS-232-C and C.C.I.T.T. Standard V24. Table 3-5 lists the signals provided at the Model 820 communications interface. A functional description of each interface signal is given in the following paragraphs.

- *Protective Ground (AA)* — This lead is connected to the terminal frame and earth ground conductor of the power cord.
- *Signal Ground (AB)* — Tied to the dc ground of the terminal power supply, this lead establishes the common ground reference for all interface signals.
- *Transmitted Data (BA)* — This lead conveys signals from the terminal data transmitter output to the data set transmitter circuitry. It is held to a MARKING condition when no data or break signals are being transmitted.
- *Received Data (BB)* — This lead conveys signals from the external data set receiver to the terminal data receiver input.
- *Request to Send (CA)* — This line is used by the terminal to control the transmitter carrier of the data set. *Request to send* is held on at all times when the terminal is configured for full-duplex operation and circuit CC (*data set ready*) is on. For half-duplex operation *request to send* is controlled by the configured line turnaround character and reverse channel options as well as the *paper-out* response and buffer response options.

Table 3-5. Interface Signals

CONNECTOR PIN NUMBER	EIA	C.C.I.T.T.	EIA NAME
1	AA	101	Protective Ground
2	BA	103	Transmitted Data
3	BB	104	Received Data
4	CA	105	Request to Send
5	CB	106	Clear to Send
6	CC	107	Data Set Ready
7	AB	102	Signal Ground
8	CF	109	Received Line Signal Detector
11	SCA	120	Secondary Request to Send
12	SCF	122	Secondary Received Line Signal Detector
20	CD	108 2	Data Terminal Ready
22	CE	125	Ring Indicator
23	CH	111	Data Signal Rate Selector

- *Clear to Send (CB)* — This line is switched on by the data set to indicate to the terminal that the data set is ready to transmit. The terminal will not attempt to transfer data across the interface when *clear to send* is off.
- *Data Set Ready (CC)* — This line is switched on by the data set to indicate that a connection has been established. The terminal will not attempt to receive or transmit data across the interface when *data set ready* is off.
- *Data Terminal Ready (CD)* — This line is switched on by the data terminal to indicate that it is ready to receive a call. Operation depends upon the position of the LINE/•/LCL switch, the configured *paper-out* response, and the configured disconnect features.
- *Ring Indicator (CE)* — This line is switched on by the data set to indicate that a ringing signal is being received on the communications line. This signal is not used by the Model 820 KSR or RO terminals.
- *Received Line Signal Detector (CF)* — This line, also called *data carrier detect*, is switched on by the data set to indicate that it has received a valid carrier signal from the remote data set. The terminal will not accept data from the interface if this signal is off. The CF Line (and no other) is regarded as on when open (floating) to permit operation with data sets such as the Bell System 113 series, which do not provide circuit CF.
- *Secondary Request to Send (SCA)* — This line, also called *transmitted reverse channel*, is held on by the terminal to switch on the reverse channel transmitter of a Bell System 202-compatible data set equipped with a reverse channel option. The transmitted reverse channel indicates that the terminal is ready to receive data when operating in the half-duplex with reverse channel communication mode (parameter 12). The SCA signal is switched off at line turnaround or when a *break* signal is transmitted in response to BREAK key actuation (KSR only) or the configured *paper-out* or *buffer* response features.

This output is also used as a terminal *ready/busy* indication for full-duplex mode in console applications (parameter 14, 15, or 16).

- *Secondary Received Line Signal Detector (SCF)* — This signal, also called *received reverse channel*, has a dual function, depending on the external data set. It is held on by Bell System 202-series data sets to indicate receipt of a valid reverse channel carrier from a remote data set. When the terminal is configured for the reverse channel feature, it will not transmit data until reverse channel is received. The terminal will treat a loss of reverse channel which exceeds 112 milliseconds as a *break* signal and will perform a line turnaround from transmit to receive mode.

Bell System 212-compatible data sets use the SCF signal as a baud rate indicator, holding the signal ON for 1200 baud operation and OFF for 300 baud. The terminal may be configured to adjust transmit and receive data rates automatically in response to this signal (parameter 29).

- *Data Signal Rate Selector (CH)* — This signal is held high by the Model 820 terminals to indicate a configured baud rate of 1200 or faster, and low to indicate a slower baud rate. If parameter 29 is selected, this signal will be held high.

3.4.2 INTERFACE SIGNAL LEVELS. When it is ON, a control line carries a positive voltage between +3 and +25 volts. When the line potential changes to a negative voltage between -3 and -25 volts, the line is considered to be OFF. The digital data exchanged between the Model 820 and an external data set consists of a series of logic ONE and ZERO signals. A logic ONE, called a *MARK*, is indicated by a negative voltage between -3 and -25 volts. A logic ZERO, called a *SPACE*, is indicated by a positive voltage between +3 and +25 volts.

In summary, a positive voltage on a *control line* is an ON condition; but a positive voltage on a *data line* represents a *SPACE* or logic ZERO. A *negative* voltage on a control line is an OFF condition, but on a data line a negative voltage represents a *MARK* or logic ONE.

3.4.3 LOCAL MODE. When the LINE/●/LCL switch is in the LCL position, the Model 820 KSR or RO terminal is in the *local mode*. In the local mode the terminal operates as follows:

1. No data is exchanged with the host system.
2. The interface signal *data terminal ready* is switched OFF.
3. Data entered on the keyboard/keypad is echoed to the printer.
4. Both the LINE RDY and CARR RCV indicators are held off.

3.4.4 STANDBY MODE. When the LINE/●/LCL switch is in the center position (●), the terminal is in the *standby mode*. In the standby mode the terminal operates as follows:

1. No data is exchanged with the host system.
2. The interface signal *data terminal ready* is maintained in its present state; that is, if the signal had been ON, it will remain on and the Model 820 will continue to monitor the communications interface signals without exchanging data. If *data terminal ready* had been OFF (local mode), the terminal maintains it off and behaves similar to local mode operation.
3. Data entered on the keyboard of the Model 820 KSR or valid code-generating keystrokes from the Model 820 RO will be echoed to the printer.

4. If *data terminal ready* is on, and data set ready is still being received by the terminal, the LINE RDY indicator will blink, indicating standby status.

NOTE

The terminal does not signal the host system when the terminal is placed in standby mode, except if parameter 14, 15 or 16 is enabled, which causes the terminal to exhibit busy status on circuit SCA.

3.4.5 LINE MODE. When the LINE/●/LCL switch is in the LINE position, the terminal is in the *line mode* or *on-line*. In the line mode the terminal operates as follows:

1. Data is exchanged with the host system in accord with the configured communications mode as explained in the following paragraphs.
2. The interface signal *data terminal ready* is switched ON.
3. Data entered on the Model 820 KSR keyboard is transmitted if a call is in progress.

3.4.5.1 Full-Duplex Operation. In full-duplex mode the transmit and receive circuits are independent. The terminal operator initiates communications mode operation by setting the LINE/●/LCL switch to the LINE position, which switches on the *data terminal ready* (DTR) line. The Model 820 KSR or RO then waits for the data set to switch on *data set ready* (DSR). When ready to exchange data with a remote device, the external data set will switch on the DSR line. If the terminal does not detect a DSR signal, it will wait (the keyboard is disabled while the terminal is waiting) until DSR switches ON.

The Model 820 terminal switches on the *request to send* (RTS) line as soon as it detects that the DSR line has been switched on by the external data set. At the same time the Model 820 causes the LINE RDY indicator on the operator control panel to start flashing.

To begin the actual data exchange two signals are now required: *data carrier detect* (also called *received line signal detector*) and *clear to send*. The receive circuit requires the *data carrier detect* (DCD) signal to be ON to begin operation, and the transmit circuit requires the *clear to send* (CTS) line to be ON. Although the receive and transmit sequences occur simultaneously, each sequence is described separately in the following discussion.

Transmit Sequence. The Model 820 terminal must receive a *clear to send* (CTS) signal from the external data set before it can transmit data. After CTS switches ON, the LINE RDY indicator on the operator control panel will stop flashing and glow steadily. The terminal then can transmit data to the external data set via the *transmitted data* (TD) line. Data from the Model 820 KSR keyboard is transmitted as it is entered; the ABM message and/or terminal reports from the RO and KSR machines are transmitted as blocks of data. The data on the TD line enters the data set, where it is modulated for transmission over the telephone line. Transmission of data may continue until the CTS or DSR signal is lost.

If the CTS line goes OFF, the LINE RDY indicator on the control panel will begin flashing and any character being transmitted will be completed, but no new characters will be transmitted until CTS switches back ON. Any characters entered via the Model 820 KSR keyboard while CTS is off are stored in a 32-character first-in-first-out (FIFO) buffer. The characters in the FIFO buffer will be transmitted when CTS switches back ON. After 32 characters are entered into the buffer with CTS OFF, an alarm will sound when entry of the 33rd character is attempted. An error code 25 will be displayed on the terminal status display (TSD) of the control panel, and the last character entered will be lost.

If DSR goes off, indicating that the call has been disconnected, the terminal LINE RDY indicator will extinguish and any characters remaining in the transmit FIFO buffer will be lost. The Model 820 will respond to the loss of

DSR by switching off RTS and DTR. DTR will remain off until DSR has been off for 3 seconds; DTR will then be switched on to prepare the data set for the next call.

Receive Sequence. The *data carrier detect* (DCD) line from the external data set must be ON for the terminal to receive data on the *received data* (RD) line. When DCD is detected by the terminal, the CARR RCV indicator on the control panel will light. If the DCD line switches off, the CARR RCV indicator will extinguish and the terminal will stop receiving data until DCD comes ON again.

3.4.5.2 Half Duplex (Without Reverse Channel) Operation. When the Model 820 KSR or RO is operating in one half-duplex mode, data communications can take place only in one direction at a time. That is, when the Model 820 KSR or RO terminal is transmitting in half-duplex mode, the remote unit must be in *receive* mode. Likewise, when the Model 820 terminal has completed transmission and is ready to receive data from the remote unit, a method is required to inform the remote to terminate receiving and begin transmitting.

The control of a remote receiving device by the transmitting unit is referred to as *line control*. The Model 820 terminals employ two different schemes to achieve line control in half-duplex mode. The first, and most prevalent, requires the use of *line turnaround (LTA) characters*. The second method, selected by enabling parameter 66 along with codes 11 or 12, utilizes no LTA characters and is discussed in Section 3.4.5.4. The LTA method is detailed in the following paragraphs.

When the Model 820 KSR or RO receives a LTA character, it switches from receive mode to a mode from which characters may be transmitted to a remote terminal. The Model 820 KSR may now transmit characters entered from the keyboard, and either Model 820 may now transmit ABM messages or one of the various reports. It is the responsibility of the transmitting unit to provide a LTA character upon completion of transmission. The receiving unit has no control of the communications lines until it receives a line turnaround character and becomes the transmitting unit.

The Model 820 can be configured to recognize any of three different turnaround characters at any given time. Any of the 128 ASCII characters may be assigned as a turnaround character. If an answerback memory (ABM) message has been programmed, the control character ENQ is also treated as a LTA character.

When the Model 820 transmits a LTA character, it waits long enough for the character to be received by the host unit, and then reverts to receive mode and accepts data from the host unit.

The operator initiates communications mode operation by setting the Model 820 terminal LINE/●/LCL switch to the LINE position. This causes the *data terminal ready* (DTR) line to switch on, informing the external data set that the Model 820 KSR or RO is ready to exchange data. When the data set switches on the *data set ready* (DSR) line, indicating the establishment of a call, the Model 820 begins to monitor the *data carrier detect* (DCD) line to determine if it should switch to the receive mode and accept any incoming data. If the operator enters a keyboard character on the Model 820 KSR, or if the automatic ABM feature is enabled and is triggered on either the Model 820 KSR or RO terminals, and DCD has not yet been received, the Model 820 will switch to transmit mode and transmit as soon as it receives the signal *clear to send* (CTS) from the data set. The Model 820 will raise its *request to send* (RTS) upon character entry or ABM triggering, but will not begin to transmit until CTS has become valid.

NOTE

The Model 820 RO terminal must be carefully programmed if it is to be used with a half-duplex data set. It can only transmit if either a status or configuration report is requested by remote unit, or if an ABM message is to be sent, either automatically triggered or requested by the host unit. No problems should occur in requesting a status or configuration report, since the Model 820 sends a LTA character at the end of the report, which should turn the line around. Care must be taken, however, with the ABM message. If a LTA character is not programmed into the message, the Model 820 RO can "lock

up” in transmit mode and never relinquish control of the communications line to the host unit. This situation can only be cleared by disconnection. Likewise, if the Model 820 KSR is to be used in an unattended situation, the same procedure should be observed since there will be no operator around to transmit a LTA character and return control to the host unit.

If the external data set switches the DCD line ON, indicating a carrier present on the communications line, the Model 820 will switch to the receive mode, the CARR RCV indicator will illuminate, and the LINE RDY indicator will remain lit.

The Model 820 will remain in the receive mode until it receives a turnaround character on the *received data* line or the call is disconnected. It is not the responsibility of the external data set to detect the line turnaround character. The data set will send the character to the Model 820 KSR or RO along with all other characters on the data line. The Model 820 Terminal is responsible for recognizing the turnaround character and for acting upon it.

When the Model 820 detects a *line turnaround character*, the receive circuits are disabled, the CARR RCV indicator extinguishes, and the RTS line is switched on. The LINE RDY indicator on the control panel will begin to flash until the external data set switches on the CTS line. After the CTS line is switched on, the LINE RDY indicator will glow steadily.

The terminal will remain in the transmit mode until a line turnaround character is transmitted. It is the responsibility of the transmitting party to ensure that the last character of a message is a line turnaround character.

3.4.5.3 Half-Duplex with Reverse Channel Operation. Half-duplex-with-reverse-channel operation is similar to half-duplex, except a low-frequency secondary channel, (commonly referred to as the *reverse channel*) is added. In a half-duplex system the transmitting unit controls the unit that is receiving. In a half-duplex-with-reverse-channel system, the receiving unit can also cause a line turnaround by use of the reverse channel.

Additional control lines are used in half-duplex-with-reverse-channel communications. The two reverse channel lines are *secondary received line signal detector* (circuit SCF) and *secondary request to send* (circuit SCA). When the Model 820 switches on the *reverse channel SCA* line, it is received by the remote unit as a *reverse channel SCF* signal. Likewise, when the remote unit switches on the *reverse channel SCA* line, it is received by the Model 820 as a reverse channel SCF signal.

No officially recognized standard exists to specify use of the reverse channel. The Model 820 terminal sequence of events for reverse channel operation is described below.

Initiation of half-duplex data communications with reverse channel is identical to the half-duplex operation described in Section 3.4.5.2 with a few exceptions. When the LINE/●/LCL switch is set to LINE, the Model 820 switches on the DTR line and waits for a DSR signal from the external data set. When the Model 820 KSR or RO detects the DSR signal from the data set, the terminal enters an idle state, holding SCA on, until the necessary parameters are detected to enable the Model 820 to switch into either the transmit or receive mode.

Transmit Sequence. If an ABM message is to be transmitted prior to DCD becoming valid, or if data is entered from the keyboard of the Model 820 KSR before DCD becomes valid, the Model 820 KSR or RO switches to the transmit mode by dropping SCA and exerting RTS. The terminal then waits for CTS and SCF to become valid before transmitting. Any data waiting to be transmitted prior to CTS and SCF becoming valid is stored in the 32-character FIFO transmit buffer of the Model 820 terminals. After CTS and SCF become valid, the LINE RDY indicator will light and the terminal will transmit the stored data via the transmitted data

(TD) line. When transmitting, the Model 820 continually checks the reverse channel SCF line. If reverse channel SCF switches off, the Model 820 KSR will hold the transmitted data line at a MARK state and start a time out. If the reverse channel SCF line returns to an ON condition within 112 milliseconds, the Model 820 will resume transmission of the characters stored in its transmit FIFO buffer. If reverse channel SCF remains off for longer than 112 milliseconds (indicating that the receiving unit has initiated a line turnaround), the terminal will switch to the receive mode: The Model 820 terminal will switch off the RTS Line, and any characters remaining in the transmit FIFO buffer will be lost.

Receive Sequence. When the Model 820 terminal switches to the receive mode, it switches on the *reverse channel transmit SCA* (secondary request to send) line. When the external data set switches on the DCD line, the Model 820 KSR or RO begins to accept data until it receives a line turnaround character. On the Model 820 KSR machine, the operator may intentionally initiate a line turnaround from receiving to transmitting by pressing the BREAK key.

If a LTA character is received (for LTA operation only), or if the BREAK key of the Model 820 KSR is pressed, the terminal will respond by switching off the *reverse channel SCA* line. The terminal will continue to accept data from the received data (RD) line until the DCD line switches off. The terminal will also monitor the *reverse channel receive SCF* (secondary received line signal) line following a turnaround from receive to transmit mode. If the reverse channel SCF does not switch on within 8 seconds after the terminal switches on the RTS Line, the RTS line will be switched off, the reverse channel SCA will switch back on, and the Model 820 terminal will return to the receive mode.

NOTE

The above description of half-duplex with reverse channel communication mode (parameter 12) is intended to explain ordinary (LTA) operation. Operation with parameter 66 enabled will be explained in the next paragraph.

3.4.5.4 No-LTA Operation (Half-Duplex Modes 11 and 12). For no-LTA operation (parameter 66 enabled) in either half-duplex mode, calls are established, signals are required, and data is transferred in exactly the same way as with ordinary LTA operation. The difference lies only in the determination of which communicating unit has control of the line.

When the Model 820 is switched on line, it remains in an idle mode until one of two things occur. If there is data to be transmitted and DCD has not yet become valid, a switch to transmit mode is effected, and the Model 820 has control of the line until it turns RTS off, at which point it again enters an idle state. Meanwhile, the host unit is assumed to have transferred from receive mode to an idle mode. If the Model 820 does not have any data to transmit at the time of connection or any time thereafter, it remains in the idle mode until DCD becomes valid, indicating that the other terminal is requesting control of the line. The Model 820 KSR or RO will then switch to receive mode and remain there until the host unit turns DCD off, whereupon both units will return to an idle state.

If the Model 820 KSR is being operated in an attended mode, return from transmit to idle mode is accomplished via simultaneous depression of the CNTL, SHIFT, and RETURN keys of the Model 820 KSR keyboard. The Model 820 KSR or RO will automatically return to idle mode after the transmission of any message or report.

3.4.5.5 Console Operation. The console modes of operation are provided for hard-wired (back-to-back), high-speed applications that do not use a data set. The console modes should not be used in conjunction with a data set; conversely, data set modes should not be used for hard-wired applications.

Table 3-6. Device Control Commands for Model 820 KSR and RO Terminals

FUNCTION TYPE	RO LOCAL/STANDBY	KSR LOCAL/STANDBY	KSR or RO LINE	DESCRIPTION
Printer Control	ESC FF	ESC -	ESC P A ESC\ or ESC P A\	Select 6 lines/inch (SS, 6 LPI)
	ESC E	ESC =	ESC P B ESC\ or ESC P B\	Select 3 lines/inch
	ESC BS	ESC _	ESC P H ESC\	Select 8 lines/inch (SS, 8 LPI)
	ESC F	ESC +	ESC P G ESC\	Select 4 lines/inch (DS, 8 LPI)
	ESC C	ESC >	ESC P C ESC\ or ESC P C\	Select 10 char/inch (Standard)
	ESC A	ESC .	ESC P I ESC\	Select 5 char/inch (Double wide standard)
	ESC D	ESC <	ESC P D ESC\ or ESC P D\	Select 16.5 char/inch (Compressed)
	ESC B	ESC ,	ESC P J ESC\	Select 8.25 char/inch (Double wide compressed)
	n/a	n/a	ESC P E ESC\ or ESC P E\	Printer Off
	n/a	n/a	ESC P F ESC\ or ESC P F\	Printer On
	n/a	ESC	Keyboard lock	
	n/a	ESC b	Keyboard unlock	
Display Control	ESC LF	ESC LINE FEED	n/a	Display current line number
	ESC SP	ESC SPACE	n/a	Display next column number
Tabulation	n/a	n/a	ESC [M	Tab right to column M
	n/a	n/a	ESC [M a	Tab right exactly M columns
	n/a	n/a	ESC [N d	Advance paper to line N (from top)
	n/a	n/a	ESC [N e	Advance paper N lines
Report Control	n/a	n/a	ESC [c	Send configuration report
	n/a	n/a	ESC [n	Send status report

Table 3-7. Forms Setup Commands for Model 820 KSR and RO Terminals

FUNCTION TYPE	RO LOCAL/STANDBY	KSR LOCAL/STANDBY	KSR or RO LINE	DESCRIPTION
Form Size	ESC 5 N CR	ESC 5 N ;	ESC [N t	Form length = N, Top of Form = Present Line
	ESC 5 CR	ESC 5 ;	n/a	Top of Form = Present Line
	ESC 5 0 CR	ESC 5 0 ;	n/a	Bottom of Form = Present Line
Form Margins	ESC 6	ESC 6	n/a	Left Margin = Present Column
	ESC DEL 6	ESC DEL 6	n/a	Left Margin = Column 1 (Default Value)
	ESC 7	ESC 7	n/a	Right Margin = Present Column
	ESC DEL 7	ESC DEL 7	n/a	Right Margin = Default Value
	ESC 8	ESC 8	n/a	Top Margin = Present Line
	ESC DEL 8	ESC DEL 8	n/a	Top Margin = Default Value
	ESC 9	ESC 9	n/a	Bottom Margin = Present Line
	ESC DEL 9	ESC DEL 9	n/a	Bottom Margin = Default Value
	ESC 0	ESC 0	n/a	Clear All Margins to Default Values
	n/a	n/a	ESC [N r	Top Margin = Line Number N
	n/a	n/a	ESC [; M r	Bottom Margin = Line Number M
	n/a	n/a	ESC [N ; M r	Top Margin = N, Bottom Margin = M
	n/a	n/a	ESC [N s	Left Margin = Column Number N
n/a	n/a	ESC [; M s	Right Margin = Column Number M	
n/a	n/a	ESC [N ; M s	Left Margin = N, Right Margin = M	
Horizontal Tabulation	ESC 1	ESC 1	ESC H	Set Horizontal Tab at Present Position
	n/a	n/a	ESC [2 g	Clear all Horizontal Tabs
	n/a	n/a	ESC [M ₁ ; . . . ; M _x u	Set Horizontal Tabs at Columns M ₁ . . . M _x (16 max)
	ESC 2	ESC 2	ESC [0 g	Clear Horizontal Tabs at Present Position
Vertical Tabulation	ESC 3	ESC 3	ESC J	Set Vertical Tab at Present Position
	n/a	n/a	ESC [4 g	Clear all Vertical Tabs
	n/a	n/a	ESC [N ₁ ; . . . ; N _x v	Set Vertical Tabs at Lines N ₁ . . . N _x (16 max)
	ESC 4	ESC 4	ESC [1 g	Clear Vertical Tabs at Present Position
Forms Storage	ESC VT N	ESC 7 N	ESC P K N ESC \	Store Present DFC Parameters in Memory N (N = 1 or 2)
	ESC TAB N	ESC \ N	ESC L N ESC \	Recall DFC Parameters From Memory N (N = 1 or 2)
	ESC TAB 0	ESC \ 0	ESC L 0 ESC \	Load DFC Default Parameters

NOTE

Attempting to select the compressed print operation, either by configuration code or DFC command, on a terminal without the compressed print option will not be allowed by the Model 820 KSR or RO terminal.

3.5.3 USER-DEFINED CONFIGURATION SETS. Configuration codes 01 through 08 are reserved in the Model 820 for user-defined configuration options. A choice of two configuration options is available; each option enables the user to predefine up to eight, complete, configuration parameter sets. The two configuration options are

- Default configuration option
- Protected configuration option.

The *default configuration* option consists of from one to eight predefined terminal configuration sets which must be specified when the Model 820 KSR or RO is purchased. Each of these sets is permanently stored in an inalterable memory (read-only type) supplied as part of the option. The currently selected set may be modified if desired, via the keyboard while in the CONFIGURE mode, by enabling or disabling any of the parameter codes. The selected set, including any parameter code changes, is stored in nonvolatile memory for retention when power is switched OFF.

The *protected configuration* option consists of from one to eight predefined terminal configuration sets which must be specified at the time of purchase. Each of these sets is permanently stored in an inalterable memory (read-only type) supplied as part of the option. No parameter changes are possible when this version of the option is installed. The selected set is stored in nonvolatile memory for retention when the power is switched off.

To select a configuration set, proceed as follows:

- a. Enter the CONFIGURE mode as described in paragraph 2.10.1
- b. Type the two-digit codes corresponding to the desired set.
- c. Momentarily press the **RETURN** key. (**CR** key of the Model 820 RO operator's keypad)
- d. Listen for an audible tone and ascertain that the code just entered is displayed, signifying that the previous configuration has been replaced with the new set.
- e. Terminate the CONFIGURE mode as described in paragraph 2.10.8.

For both the protected and default configuration options any attempt to select a configuration for which no parameter set is defined will cause a configuration error status. If either configuration option is installed, the terminal will default to the configuration set defined by code 01 (rather than the standard default configuration defined by code 09) upon failure of the power-up diagnostic test of nonvolatile memory.

3.5.4 ALTERNATE CHARACTER SET KEYBOARD — ASCII/APL (Model 820 KSR Only). The optional APL keyboard shown in Figure 3-6 enables the terminal to transmit and receive both the standard ASCII and the APL characters. The SO-SI/LOCK switch and ALTN CHAR indicator shown in Figure 3-7 are added to the control panel with this option installed. The SO-SI/LOCK switch, in conjunction with the O, N, and CTRL keys and the control codes SI and SO, permit selection of either the APL or the ASCII mode. With the SO-SI/LOCK switch in the SO-SI position and the terminal in the LCL mode, APL mode is selected by pressing the N key while the CTRL key is pressed and held [which generates the control character SO (*shift out*)]. The ALTN CHAR (alternate character) indicator lamp will light to signify that the terminal is in the APL mode. The

3.5.5 NUMERIC KEYPAD (Model 820 KSR Only). An optional 18-key numeric keypad is available for high volume data entry applications. Since the numeric keypad must be physically mounted on the main keyboard printed-wiring circuit, this option is usually factory installed. Field upgrade requires replacement of the keyboard assembly.

Numeric keypad layout and symbolization are shown in Figure 3-8. The keypad is available on the standard ASCII and on the optional APL keyboards. The ENTER key is user-programmable as described in Section II. None of the keys on the numeric keypad have automatic-character-repeat operation. The mode control keys (i.e., SHIFT, UPPER CASE, and CTRL) of the typewriter keyboard have no effect on the numeric keypad functions.

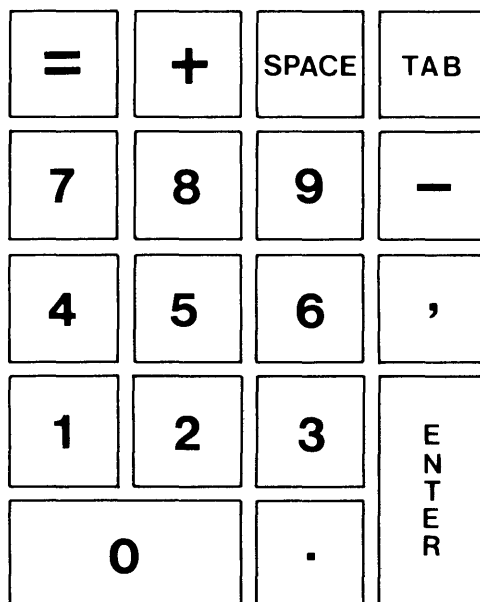

Figure 3-8. Numeric Keypad

3.5.6 20 mA CURRENT-LOOP INTERFACE. An optional 20 mA current loop interface is available for both the Model 820 KSR and Model 820 RO data terminals. This interface provides an alternate arrangement for data transfer in hard-wired applications. If installed, the current-loop PWB is located beneath the operator's panel and has a connector assembly attached to the rear of the Model 820 KSR or RO case. To operate the Model 820 KSR or RO terminal using the current-loop option, do the following:

- a. Connect the Model 820 KSR or RO to the host unit via proper cabling connected to the 9-pin connector at the rear of the terminal.
- b. Configure the Model 820 to parameter 16 plus the proper baud rate parameter and the proper parity parameter necessary for the host unit's operation.
- c. Add any extra configuration parameters desired for terminal control.

NOTE

Parameter 16 is identical to parameter 14, except that the current loop interface is now enabled. Accordingly, no disconnect parameters or ABM parameters or LTA parameters will be functional.

- d. Insert the shorting plug into the EIA interface socket on the rear of the Model 820. Insure that all connections are secure.
- e. Switch the LINE/●/LCL switch to LINE. The Model 820 KSR or RO is now ready to communicate with the host unit.

3.6 OPERATOR'S REFERENCE CARDS

A set of *Operator Reference Cards* is contained in the pull-tab tray located at the front left corner of the terminal. These cards provide a summary of the operational features of the Model 820 KSR or RO terminal.

SECTION IV

THEORY OF OPERATION

4.1 GENERAL

This section describes the theory of operation of the Model 820 KSR/RO terminals. The Model 820 terminals consist of the following major functional components:

- Power Supply
- Terminal Controller
- Operator Interface
- Communications Interface
- Ribbon Drive Subsystem
- Paper Drive Subsystem
- Printhead Carriage Drive Subsystem
- Printhead Subsystem

A block diagram illustrating the relationship of the functional components is shown in Figure 4-1. In addition to the simplified diagrams accompanying this discussion, the text also lists references to the logic diagrams and schematics reproduced in Section VII of this manual. On the logic diagrams a signal is considered active when it is high (logic ONE) unless a slash (/) appears before the mnemonic, in which case it is considered active when it is low (logic ZERO). The mnemonics for all signals are listed in Appendix F of this manual.

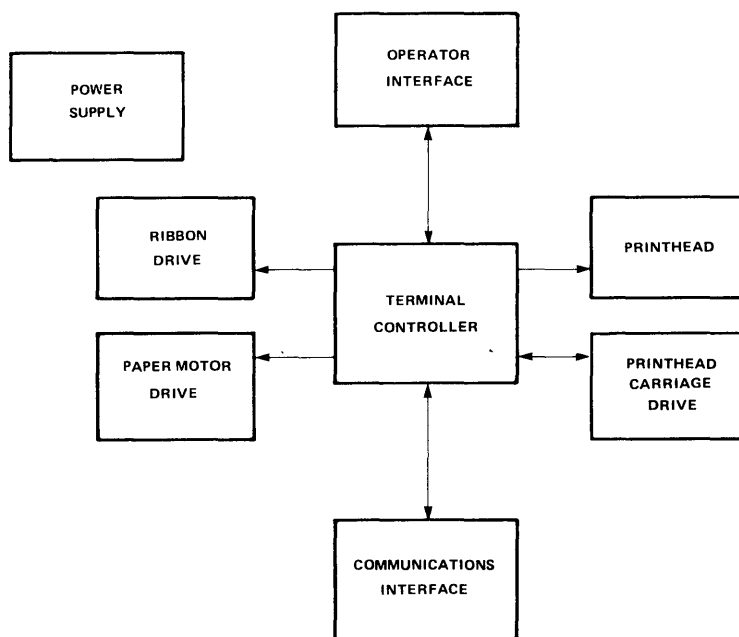

Figure 4-1 Model 820 KSR/RO Simplified Functional Block Diagram

4.2 POWER SUPPLY

The Model 820 power supply operates on a self-referencing power conversion principle. The self-referencing power converter operates over an input voltage range of 90 to 280 Vac at a frequency range of 47 to 400 Hz. Jumpers, plus movement of two thermistors on the terminal electronics printed-wiring board switch the terminal from 115 Vac to 230 Vac operation.

The self-referencing power supply consists of six major parts:

- Input voltage selection and rectification
- Soft-start circuit
- Blocking oscillator
- Reference/sense circuit
- Secondary filtering and regulation
- Power-good circuit

A simplified block diagram of the Model 820 KSR/RO power supply is shown in Figure 4-2. Schematics of the power supply are shown on sheets 13 and 14 of drawing 999945 in Section VII.

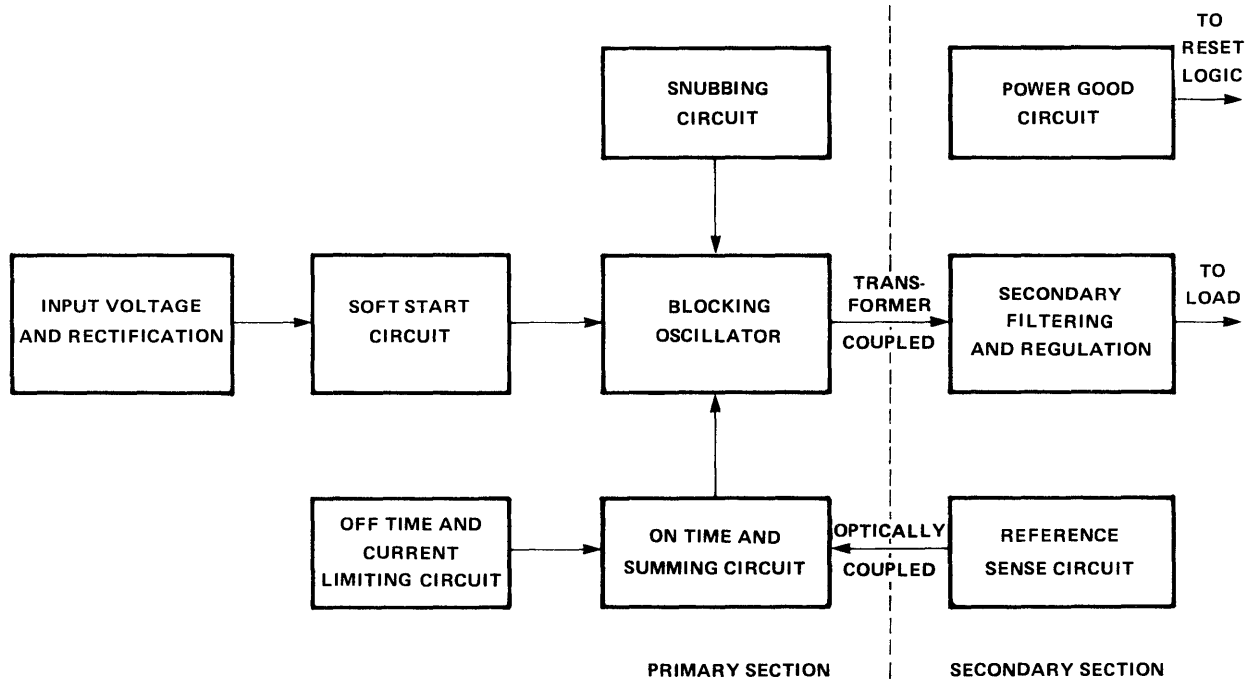

Figure 4-2. Power Supply Block Diagram

4.2.1 INPUT VOLTAGE SELECTION AND RECTIFICATION. Power is supplied through the line filter and power-on switch (drawing 999835) to E271 and E281 (drawing 999945, sheet 13). If the terminal is configured for 115 VAC operation, thermistors R272 and R273 are installed to form a voltage doubler as shown in Figure 4-3a. For 230 VAC operation, thermistors R274 and R275 are installed to form a full wave bridge as shown in Figure 4-3b. The jumper between E285 and E286 acts as a switch to indicate the input voltage configuration to automatic test equipment. Capacitor C262 is an AC bypass from the 325 V return to chassis ground and capacitors (C258 and C259 provide the primary energy storage for the terminal.

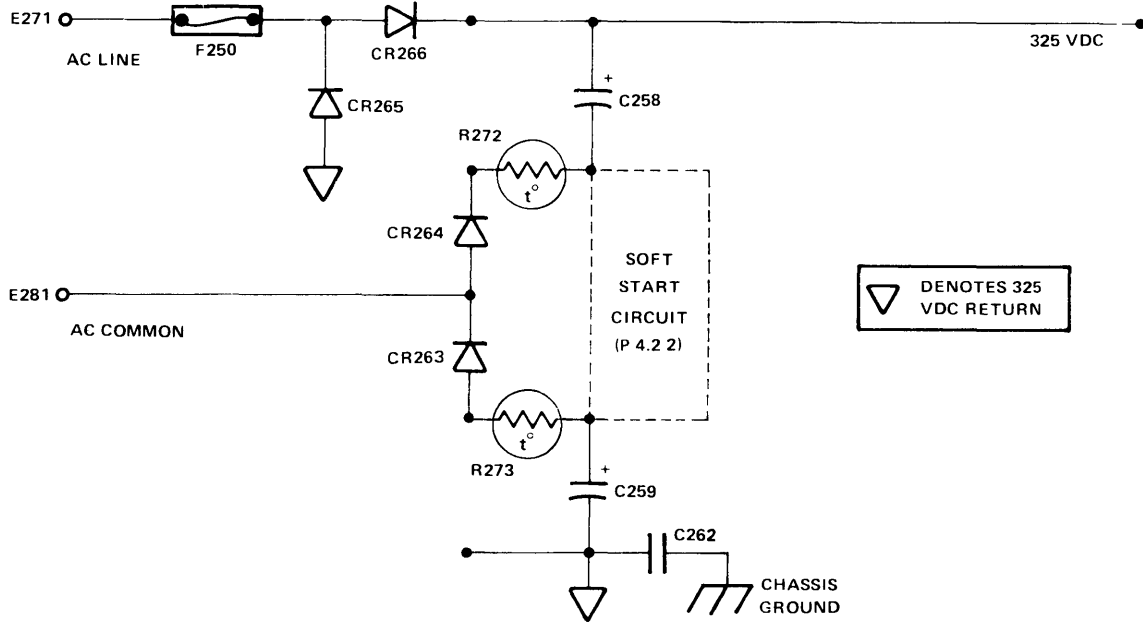

Figure 4.3a. Input Voltage Selection and Rectification

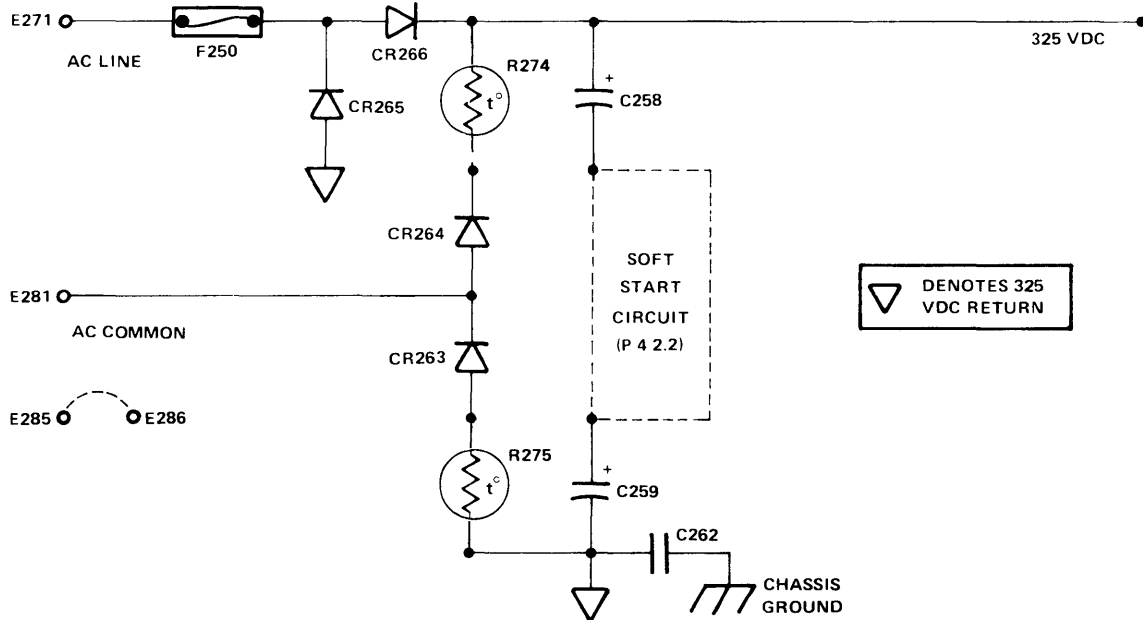

Figure 4.3b. Input Voltage Selection and Rectification

4.2.2 SOFT-START CIRCUIT. During power-up initial current surge is limited by resistor R271 in the soft-start circuit as shown in Figure 4-4. After a safe period, when capacitors C258 and C259 are charged, SCR Q255 fires and bypasses R271 for more efficient operation. Resistors R269 and R270 with capacitor C261 provide the RC time constant delay used to fire the soft-start SCR. R268 and C260 filter the voltage on the gate of Q255, CR262 provides a low-impedance path around R271 when C258 and C259 discharge. C263 provides transient protection to prevent false triggering of Q255.

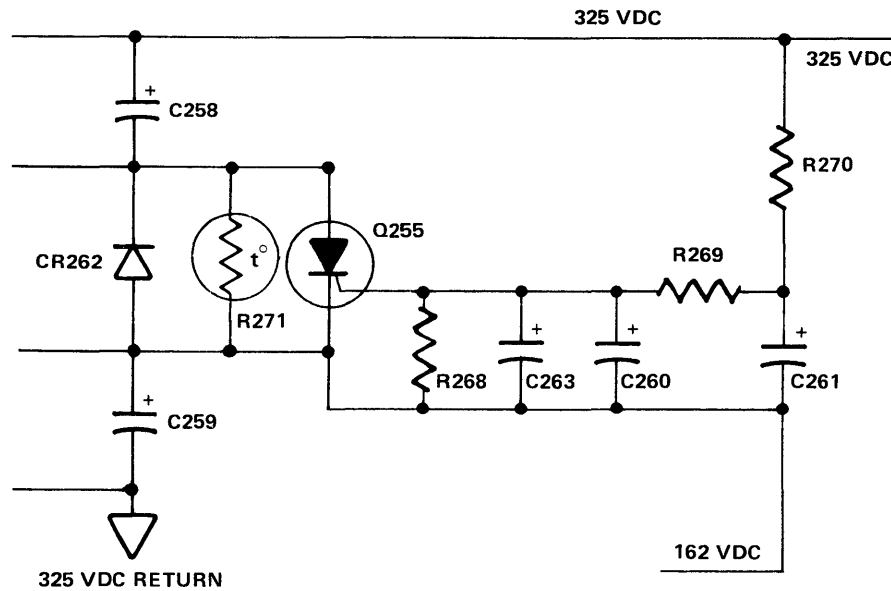

Figure 4-4 Soft-Start Circuit

4.2.3 BLOCKING OSCILLATOR CIRCUIT. The blocking oscillator circuit (drawing 999945, sheet 13) is a self-starting switching circuit which uses the primary winding of transformer T201 as a collector load. When the switching transistor is on, energy is stored in the primary winding of transformer T201. When the switching transistor goes off, the induced electromagnetic field in the primary collapses and couples energy into the secondary windings of the transformer.

Transistor Q250 controls the current being applied to the primary winding of T201. When Q250 is switched on, current passes through the primary winding of T201 and current sensing resistor R251. Transistor Q251 follows the voltage changes of R251 and applies a ramp voltage proportional to the current change through R251 to a summing point at R259.

The summing point receives the ramp voltage from Q251 and from the reference sensing circuit connected to the secondary windings of T201. When the voltage at this summing point reaches approximately 0.6 volts, transistors Q252, Q253, and Q254 switch on which, in turn, switches off Q250. The current through the primary of T201 stops, and the induced field begins to collapse. The collapsing field couples energy to the secondary windings through flyback action. Q250 remains off until the voltage at the summing point allows transistor Q252 to switch back off.

Two jumpers are provided in the blocking oscillator circuit to assist in testing. The jumper between E264 and E265 connects the collector of Q250 to T201. The jumper between E262 and E263 connects the base of Q250 to the self-starting circuit R265.

4.2.4 REFERENCE SENSING CIRCUIT. The 5-volt winding rectified by CR205 (drawing 999945, sheet 14) is used as the reference winding. Because of the tight coupling used in the secondary windings of T201, any load variations in the other secondaries will be reflected in the 5-volt winding. The 5-volt output is tapped off before fuse F200 and applied to pin 2 of operational amplifier (op-amp) U202. The output of the 5-volt winding is compared to a reference voltage, the output of the op-amp is high, and switching transistor Q250 continues to deliver full power into the primary winding. When the input at pin 2 exceeds the reference voltage, the output of the op-amp is optically coupled back to the summing point at R259 where it is combined with the ramp voltage to switch off transistor Q250.

4.2.5 SECONDARY FILTERING AND REGULATION CIRCUITS. Transformer T201 has four secondary windings which are used to produce the voltages required to drive the terminal. The windings produce 33 volts, +5 volts, and ± 16 volts. The +33 volt winding is rectified by CR203 and then split to facilitate testing the motor driver and printhead circuits. The jumper from E205 to E206 connects +33 volts to +33 VHD which applies +33 volts to the ribbon motor drive through fuse F101 and to the printhead through F102. The jumper from E207 to E208 connects +33 volts to +33 VMTR which applies +33 volts to the carriage motor drive and papermotor drive through fuse F103.

The output of the +5 volt winding is rectified by CR205, filtered, and sensed by the reference/sensing circuit. The +5 volt supply is split after fuse F200 to facilitate testing of the driver and logic circuits. The jumpers from E211 to E212 (and E234 to E235) connect +5V to the logic circuits. The jumper from E213 to E214 connects +5V to +5DVR for the motor driver circuits and is used to develop +5 VSW (drawing 999945, sheet 14).

The 16-volt secondary rectified by CR209 is filtered and input of the three-terminal regulator U20; this output is the regulated +12 volt supply for the terminal. The second 16-volt winding is filtered and regulated by regulator U206; this produces the -12 volt supply for the terminal.

4.2.6 POWER-GOOD CIRCUIT. The power-good circuit (PWRGOOD) monitors the power supply voltages and produces a logic output signal that enables terminal operation. If either of the power supply voltages (+5 or -12) drops to less than 95 percent of its normal voltage output, transistor Q201 (drawing 999945, sheet 14) switches on, sinking the PWRGOOD signal to ground. The loss of the PWRGOOD signal causes a RESET interrupt at the terminal processor CPU, disables all printer mechanism drive circuits by disabling the +5 VSW drive enable signal, and resets the Z-80A CTC's, the Z-80A SIO, the dot and keyboard latches, as well as the communications interface latches.

4.3 TERMINAL CONTROLLER SUBSYSTEM

The Model 820 KSR/RO terminal controller is a Z80A microprocessor. A simplified block diagram of the terminal controller subsystem is illustrated in Figure 4-5. The major components of the terminal controller subsystem are:

- Z-80A (or equivalent) microprocessor
- System clock circuit
- Memory control logic
- Two Z-80A CTC's (Counter-Timer Circuits)
- Memory

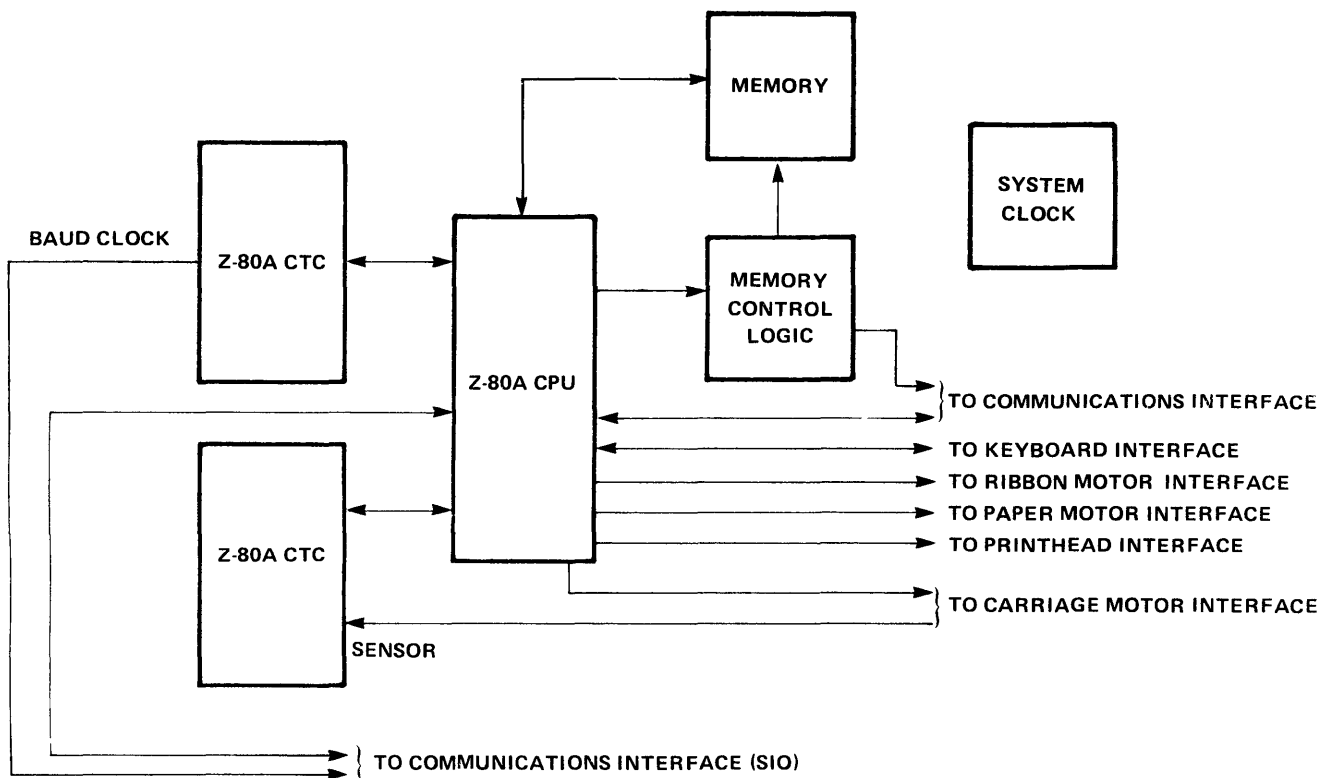

Figure 4-5 Terminal Controller Subsystem

4.3.1 THE Z-80A MICROPROCESSOR

The Z-80A Microprocessor, TI part number 2210301-0001, is the 4 MHz version of the popular Z-80 microprocessor. Several companies source this CPU using different designations, but for simplicity's sake we shall use the term Z-80A to designate this family of microprocessors throughout this section.

The Z-80A is an eight-bit microprocessor with a tri-state, bi-directional data bus and a sixteen-bit, tri-state address bus, allowing access to up to 65,536 bytes (eight-bit data words) of memory. The CPU, built using MOS LSI technology, requires only a regulated +5 volt supply and ground for power, plus a single phase clock of up to 4 MHz for system timing.

The Z-80A is upwardly software compatible with the 8080A microprocessor, with an instruction set of 158 instructions, including the 78 of the 8080A. On-board scratchpad memory is implemented in a manner similar to that of the 8080A, but in greater quantity. The Z-80A contains 208 bits of read/write memory organized into eighteen eight-bit registers and four sixteen-bit registers, and implemented in on-chip static RAM.

The Z-80A, similar to the 8080A, uses a stack architecture for many internal operation (such as CALL, RETURN, etc.) and external operations performed within a program, such as saving registers while executing subroutines (PUSH, POP). A stack is also referred to as a last-in, first out (LIFO) buffer, or a pushdown array. The stack in the Z-80A architecture is implemented in external system RAM, and referenced via the CPU's stack pointer (SP) register. The stack pointer points to a spot in contiguous RAM, and is decremented when data (primarily addresses) is "pushed" onto the stack, and is incremented when data is removed or "popped" off the stack. For instance, if the SP is loaded with 9000H (hexadecimal) and a PUSH instruction is executed, the contents of the registers being pushed is placed at location 9000H and 8FFFH (2 8-bit data words), and

the new SP is now 8FFEh. The reverse occurs with a POP instruction. The Z-80A CPU also uses the stack to store return addresses during interrupt service or execution of CALL instructions, and to return to the calling or interrupted program upon execution of a return-class instruction.

The Z-80A CPU may be configured to any one of three modes of interrupt handling. Mode 0 is similar to the 8080A mode in which interrupting devices set an instruction on the data bus for execution by the CPU. Mode 1 causes a restart at address 0038H upon acknowledgement of the interrupt. Mode 2, the most powerful mode, and that used by the Model 820 terminals, enable indirect calls to any location in memory for execution of an interrupt handler routine. Included in every mode is a non-maskable interrupt which is actuated via the /NMI pin of the CPU. It causes a restart at location 0066H, but is only used in the Model 820 terminals for internal test purposes. All modes of interrupt are selected via software instructions.

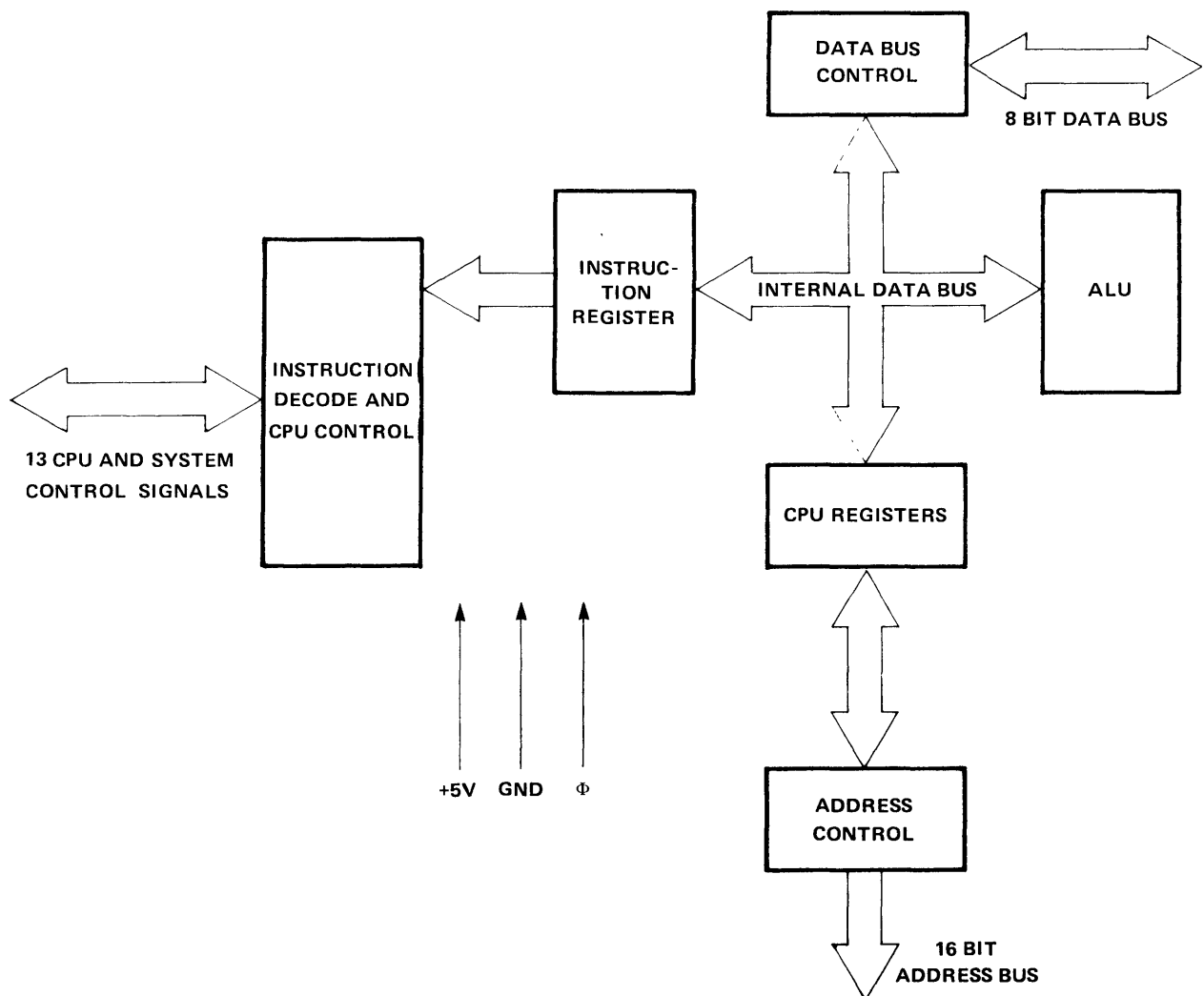

Figure 4-6 Z-80A Architecture

4.3.2 Z-80A CPU TIMING. The Z-80A CPU executes instructions by performing a small set of basic internal operations unique for each instruction. Those operations most applicable to the Model 820 Terminals include:

- Instruction OP code fetch (M1 cycle) (used to fetch instructions from ROM)
- Memory data read or write cycles (used to read from RAM, option ROM, dot ROM, PROM's, I/O devices)
- I/O read or write cycle (Used to read or write from I/O devices)
- Interrupt Request/Acknowledge Cycle (used to handle interrupts)

Timing diagrams for these cycles (with and without wait-state as applicable) are shown in the following figures. Further explanation can be found in a Z-80A CPU manual.

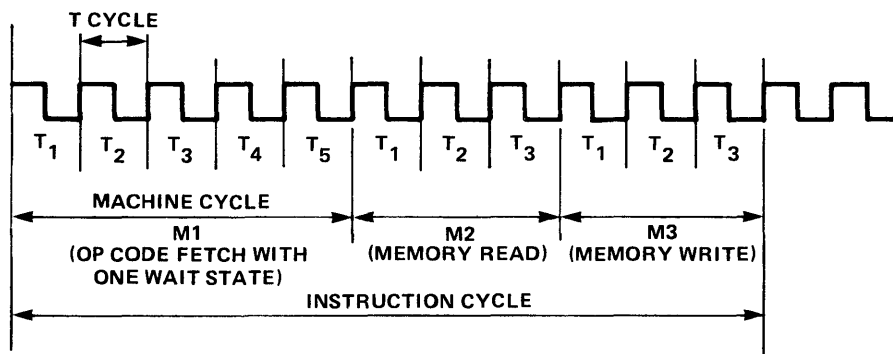

Figure 4-7. Basic CPU Timing Example

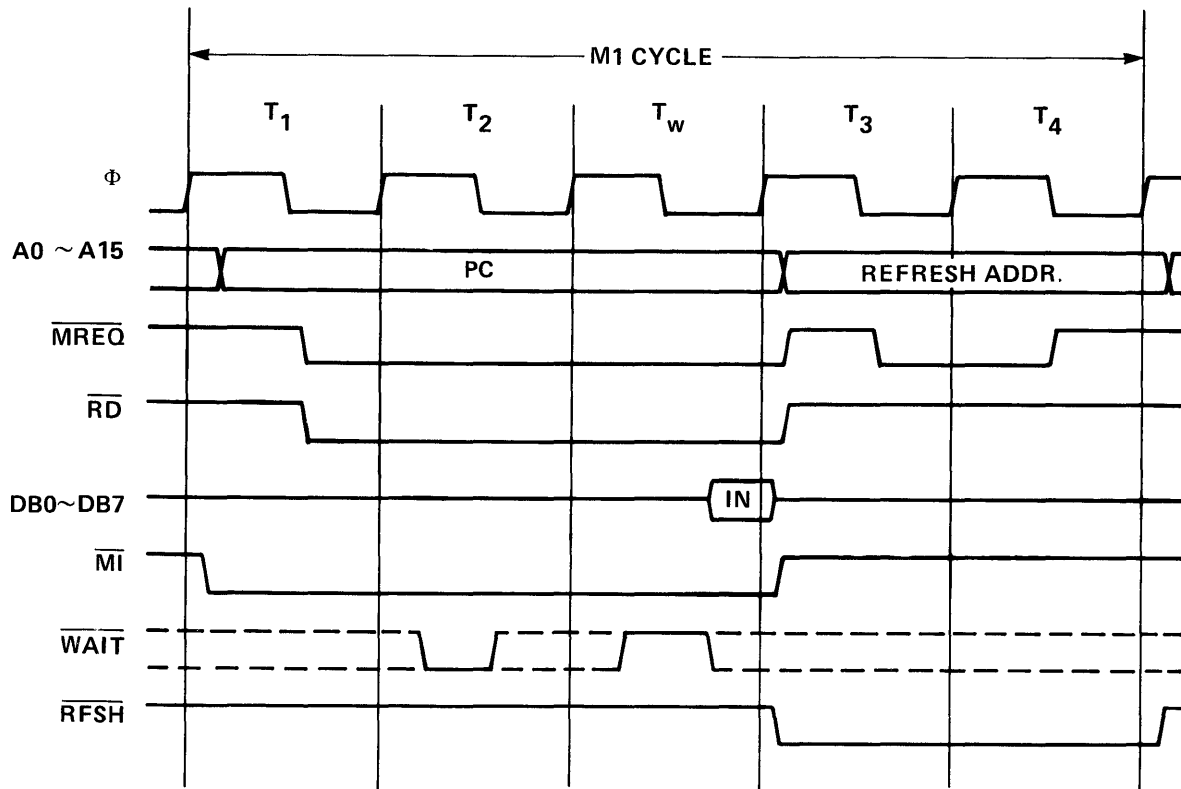
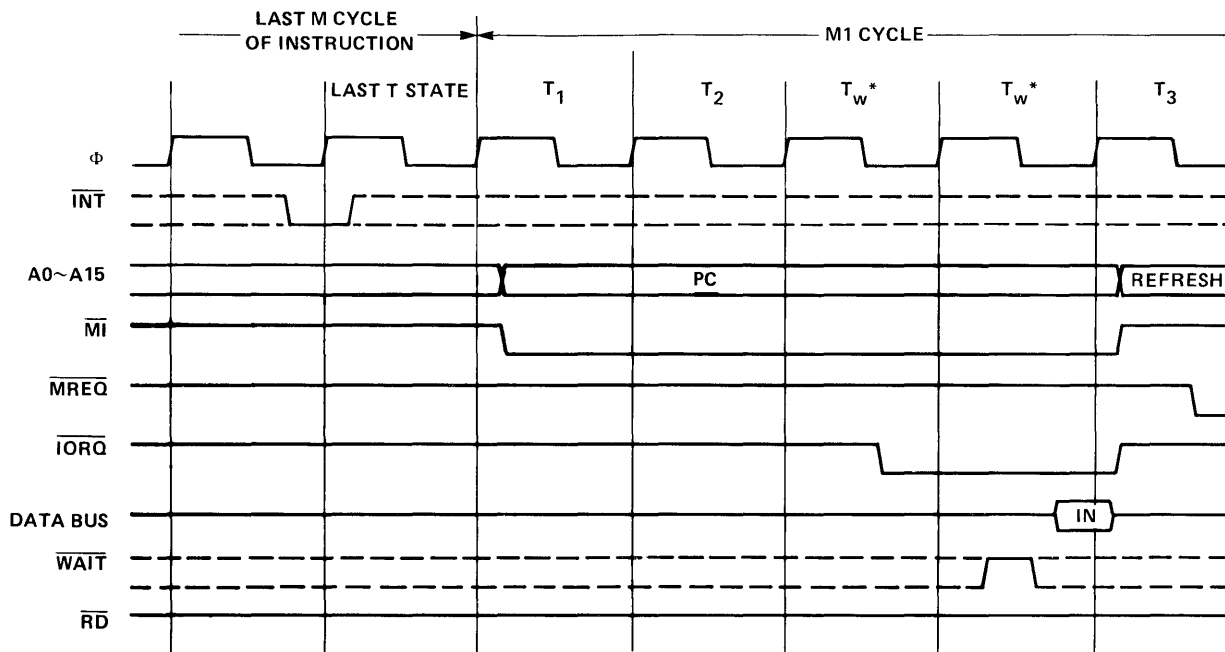

Figure 4-8. Instruction Op Code Fetch With One Wait State



NOTE: The * indicates that these wait states are automatically inserted by the Z-80A CPU.

Figure 4-9. Interrupt Request/Acknowledge Cycle

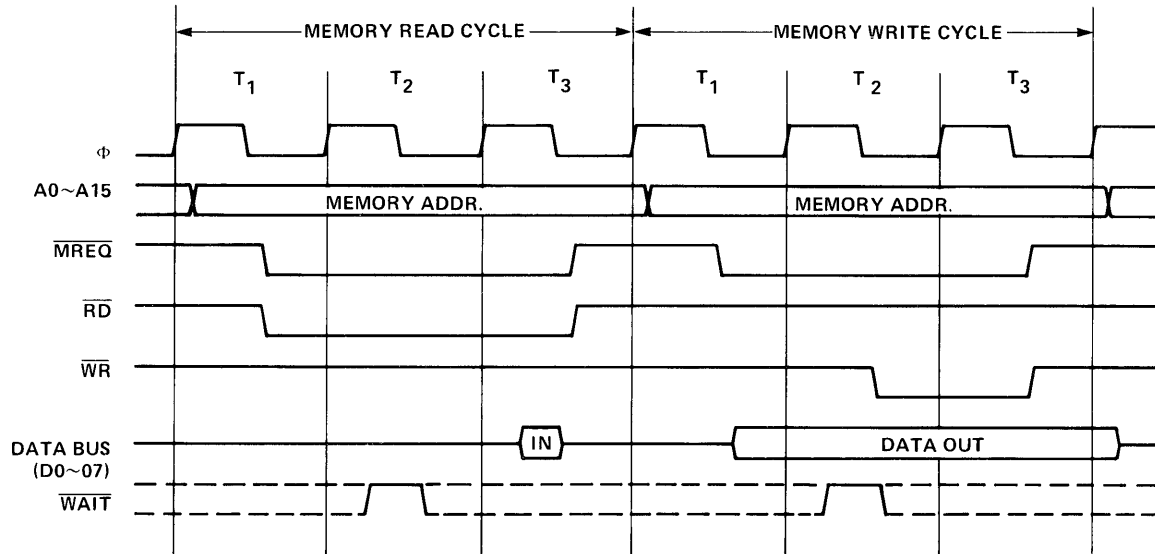

Figure 4-10. Memory Read Or Write Cycles

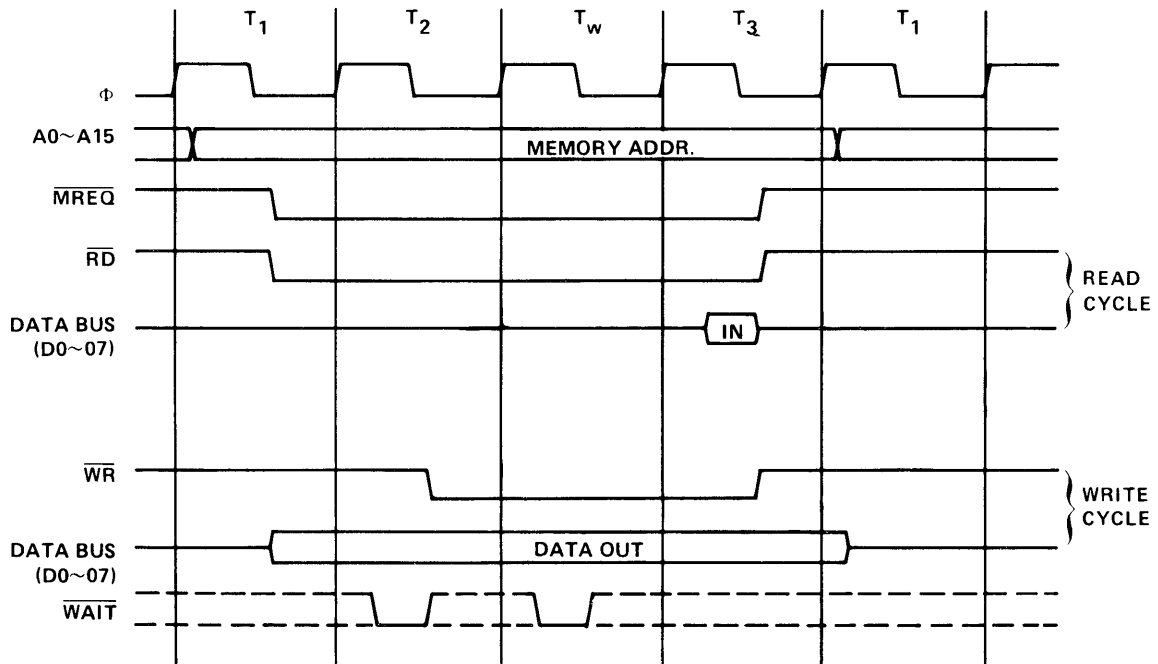

Figure 4-11. Memory Read Or Write Cycles With One Wait State

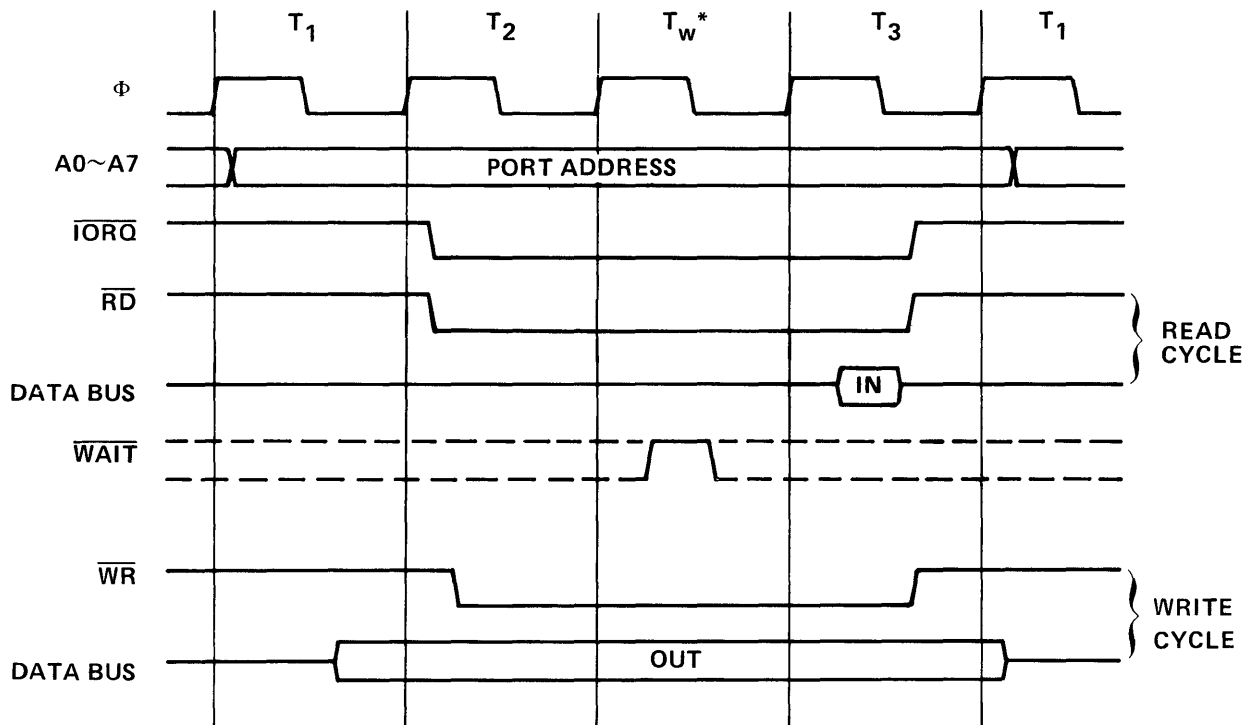

Figure 4-12. Input Or Output Cycles

4.3.3 TERMINAL CONTROLLER MEMORY. The memory used by the terminal controller subsystem is composed of:

- Read-only memory (ROM)
- CMOS random access memory (CMOS RAM)
- Random access memory (RAM)
- Programmable read-only memory (PROM)

The terminal controller memory schematics are located in Section VII, drawing 999945, sheets 5 and 6. The references in the following paragraphs apply to these schematics.

4.3.3.1 Read-Only Memory. The control programs and built-in testing functions for the standard Model 820 KSR and RO terminals are contained in 16K bytes of read-only-memory (ROM) located on the terminal electronics PWB (main board). The terminal controller ROM consists of two 8K by 8-bit TMS4764-compatible devices installed in sockets XU9 and XU10. Data is exchanged with the ROM's via the Z-80A bi-directional data bus. The ROM's are enabled by the memory control logic (refer to paragraph 4.3.4) and are addressed via the Z-80A address lines. An optional TMS4732 — compatible ROM (socket XU12) is provided with the Device/Forms Control (DFC) option.

4.3.3.2 Nonvolatile Memory. The Model 820 terminals use two complementary metal oxide semiconductors (CMOS) random access memories (RAM's) and a battery to provide nonvolatile storage of configuration and format parameters. The CMOS RAM's contain 256 bytes (each one is 4 bits wide) of memory and

are located on the terminal electronics PWB (U4 and U5). The CMOS RAM's are enabled by the memory control logic. When power to the Model 820 is switched off, a +3 volt, silver oxide battery provides power to the CMOS RAM's (refer to Section V for information on battery installation and replacement).

4.3.3.3 Random Access Memory. The terminal electronics PWB has 2048 (2K) bytes of RAM for temporary storage of data and stack manipulation by the Z-80A. The terminal processor RAM consists of two 1K by 8-bit MK4118-compatible RAM devices in sockets XU2 and XU3. The RAM is enabled by the memory control logic.

4.3.3.4 Programmable Read-Only-Memory (Optional). The terminal electronics PWB provides two programmable read-only-memory (PROM) sockets, XU23 and XU24, which are used for optional character sets and fixed configurations. Refer to Section III for details on these options.

Figure 4-13 illustrates the Memory Map.

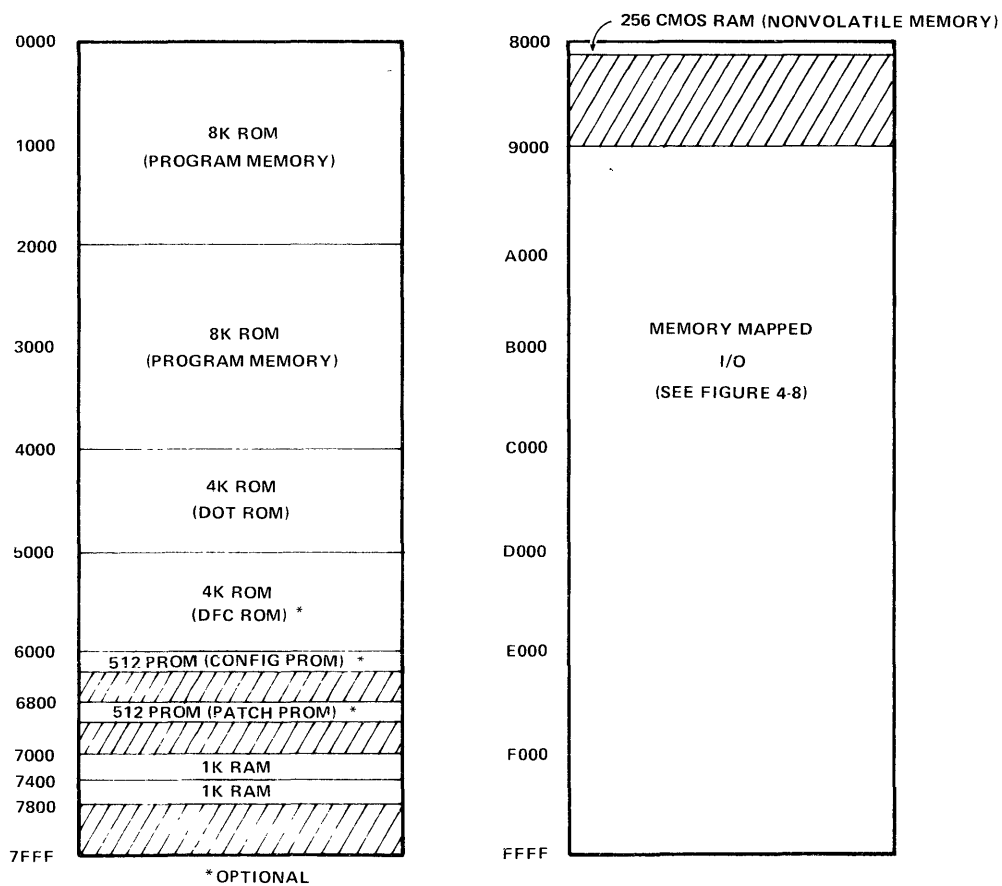

Figure 4-13. Memory Map

4.3.4 MEMORY CONTROL LOGIC. The memory control logic is the control interface between the Z-80A CPU and the various memory circuits and memory-mapped I/O circuits in the Model 820 KSR and RO terminals. This interfacing is accomplished via the use of select signals which selectively enable the device to be accessed. Figure 4-14 shows the Memory Mapped I/O.

MEMORY MAPPED I/O

A15	A14	A13	A12	A11	A10	A9	A8	A7	A6	A5	A4	A3	A2	A1	A0	D7	D6	D5	D4	D3	D2	D1	D0
1	0	0	1	0	X	X	X	X	X	X	X	X	X	X	X	KBD7	KBD6	KBD5	KBD4	KBD3	KBD2	KBD1	KBD0
1	0	0	1	1	X	X	X	X	X	X	X	X	X	X	X	DIRECT	STLSFG	RIBREV	PAPOUT		SCARDET	RI	DSR
1	0	1	0	X	X	X	X	X	X	X	X	X	X	X	X	XMIT R7	ALT R6	CARRIER R5	R4	(MSB) DATA 0 R3	DATA 1 R2	DATA 2 R1	(LSB) DATA 3 R0
1	0	1	1	X	X	X	X	X	X	X	X	X	X	X	X	RBA	RBB	RBC	RBD	(MSB) STB 0 R11	R10 STB 1 R10	(LSB) STB 2 R9	R8
1	1	0	0	X	X	X	X	X	X	X	X	X	X	X	X	DOT 8	DOT 7	DOT 6	DOT 5	DOT 4	DOT 3	DOT 2	DOT 1
1	1	1	0	X	X	X	X	X	X	X	X	X	0	0	0	X	X	X	X	X	X	X	BELL ON = 1
1	1	1	0	X	X	X	X	X	X	X	X	X	0	0	1	X	X	X	X	X	X	X	COCHR 1 = COMP
1	1	1	0	X	X	X	X	X	X	X	X	X	0	1	0	X	X	X	X	X	X	X	LOOPBACK = 1
1	1	1	0	X	X	X	X	X	X	X	X	X	0	1	1	X	X	X	X	X	X	X	SRTS
1	1	1	0	X	X	X	X	X	X	X	X	X	1	0	0	X	X	X	X	X	X	X	RATE
1	1	1	0	X	X	X	X	X	X	X	X	X	1	1	0	X	X	X	X	X	X	X	X1
1	1	1	0	X	X	X	X	X	X	X	X	X	1	1	1	X	X	X	X	X	X	X	X2
1	1	1	1	X	X	X	X	X	X	X	X	X	0	0	0	X	X	X	X	X	X	X	STPTFG
1	1	1	1	X	X	X	X	X	X	X	X	X	0	0	1	X	X	X	X	X	X	X	CMFWD1=FWD
1	1	1	1	X	X	X	X	X	X	X	X	X	0	1	0	X	X	X	X	X	X	X	ACC1 1=ON
1	1	1	1	X	X	X	X	X	X	X	X	X	0	1	1	X	X	X	X	X	X	X	ACC2 1=ON
1	1	1	1	X	X	X	X	X	X	X	X	X	0	1	1	X	X	X	X	X	X	X	PDMCC1=HIGH
1	1	1	1	X	X	X	X	X	X	X	X	X	1	0	0	X	X	X	X	X	X	X	POA
1	1	1	1	X	X	X	X	X	X	X	X	X	1	0	1	X	X	X	X	X	X	X	POB
1	1	1	1	X	X	X	X	X	X	X	X	X	1	1	0	X	X	X	X	X	X	X	POC
1	1	1	1	X	X	X	X	X	X	X	X	X	1	1	1	X	X	X	X	X	X	X	POD

X's Denote Don't Cares

Figure 4-14. Memory Mapped I/O

The select signals are generated in a decoding network comprised of a 32x8-bit PROM (U13, drawing 999945, sheet 4) and two 74LS138 one-of-eight decoder/demultiplexers (U25 and U26, drawing 999945, sheet 4). The network decodes the five most significant address lines of the Z-80A CPU (A15-A11) and two control signals from the CPU (/MREQ and /WR) to produce the enable signals for four ROM's, two RAM's, the composite CMOS RAM, two optional PROM's, seven I/O circuits, and the wait-state generator. Drawing 999945, sheet 4 shows the exact routing of these signals. Other memory-mapped I/O, specifically the Z-80A CTC's and SIO, are powerful enough to do their own address decoding, so none is needed in this logic for those three devices. The address table for the Z-80A CTC's and SIO is shown in Figure 4-15.

A15 A14 A13 A12 A11 A10 A9 A8 A7 A6 A5 A4 A3 A2 A1 A0	DESCRIPTION	DEVICE
X X X X X X X X 0 1 1 1 X X 0 0	PRINT PULSE TIMER	CTC 2
X X X X X X X X 0 1 1 1 X X 0 1	PAPER MOTOR TIMER	CTC 2
X X X X X X X X 0 1 1 1 X X 1 0	BAUD RATE CLOCK	CTC 2
X X X X X X X X 0 1 1 1 X X 1 1	4 MS TIMER	CTC 2
X X X X X X X X 1 0 1 1 X X 0 0	SENSOR INTERRUPT TIMER	CTC 1
X X X X X X X X 1 0 1 1 X X 0 1	SENSOR TIMER (LSB)	CTC 1
X X X X X X X X 1 0 1 1 X X 1 0	SENSOR TIMER (MSB)	CTC 1
X X X X X X X X 1 0 1 1 X X 1 1	SPEED REGULATION TIMER	CTC 1
X X X X X X X X 1 1 0 1 X X 0 0	CHANNEL A DATA	SIO
X X X X X X X X 1 1 0 1 X X 0 1	CHANNEL A CONTROL	SIO
X X X X X X X X 1 1 0 1 X X 1 0	CHANNEL B DATA	SIO
X X X X X X X X 1 1 0 1 X X 1 1	CHANNEL B CONTROL	SIO

X's Denote Don't Cares

Figure 4-15. I/O Devices

4.3.5 SYSTEM CLOCK. The terminal electronics board PWB employs a 4 MHz crystal-controlled oscillator to provide the clock pulses for the Model 820 KSR and RO terminals. The output of the system clock (OSC) is buffered and inverted by device U29, a 74LS244. The new signal, /CLK, is routed to the encoder circuit of the carriage motor subsystem, to the flip-flop (U30) which divides the clock by two for use in generating the baud clock, to the wait-state generator flip-flops (U30A and U40A), and to a bipolar driver/inverter circuit which generates the signal CLKMOS. CLKMOS is the Z-80A CPU clock signal as well as the master clock signal for the two Z-80A CTC circuits and the Z-80A SIO.

4.3.6 THE Z-80A CTC COUNTER TIMER CIRCUIT. The Models 820 KSR/RO Terminals use two Z-80A CTC's to provide miscellaneous timing functions. The Z-80A CTC is the 4 MHz version of the Z-80 CTC, both being 4-channel independent timer/counters capable of generating interrupts upon a count down to zero in any of the four individual channel registers.

The Model 820 KSR/RO Terminals use these two CTC's (drawing 999945, sheet 7, U21 and U22) to provide sensor pulse counting (as explained in Section 4.8.1), to reset the printed latches (as explained in Section 4.9, RE: CLRDOTS), to generate a general purpose interrupt every four milliseconds, to generate the baud rate clock for the Z-80A SIO (see Section 4.5.3), to time paper movement, to regulate carriage speed, and to measure the length of time between sensor pulses.

4.4 OPERATOR INTERFACE

The upper PWB of the Model 820 KSR Terminal contains the operator interface which consists of the alphanumeric keyboard, the operator control panel, the terminal status display block, terminal indicators, and

optional numeric keyboard, and associated support circuits. The upper PWB of the Model 820 RO Terminal is much the same, except that instead of an alphanumeric keyboard, there is a operator's keypad for use in configuration and testing. There is no numeric keyboard option on the Model 820 RO Terminal.

The operator interface components are connected to the terminal controller processor through the keyboard interface (drawing 999945, sheets 7 and 8). The keyboard scan, matrix, terminal status display and indicators, and the interface logic are described in the following paragraphs.

4.4.1 KEYBOARD/SWITCH SCAN. The keyboard is scanned once every four milliseconds. During each scan the keyboard matrix is read, the terminal indicators are updated, and one of the seven-segment LED displays on the operator's panel is updated. Three keyboard scans are required to completely update the keyboard displays. At the beginning of the keyboard matrix scan, the terminal controller loads a digital word into latches U36 and U37 in the interface logic. This word places a ZERO on row zero (R0) and ONE on rows one (R1) through row eleven (R11). Therefore, at the beginning of the scan, only row R0 is enabled. After reading the column outputs, the data is right-shifted and rewritten to the latch, meaning that only R1 is now enabled. The columns are read again. The data is right-shifted every time the columns are read until all of the rows have been enabled once.

4.4.2 KEYBOARD MATRIX. The keyboard matrix encodes key/switch actuation information to be read by the terminal controller. The matrix for the Model 820 KSR Terminal keyboard consists of twelve rows and eight columns (drawing 999710, sheet 2). The matrix for the Model 820 RO Terminal keyboard consists of twelve rows and four columns (drawing 999951, sheet 2). The rows are enabled (low) one at a time by the terminal controller. When a key connected to an enabled row is depressed, current flows through a 6.8K ohm pullup resistor and through the key switch. Here current flow is slightly different dependent on whether the keyboard is a RO model or a KSR model as delineated in the following paragraphs.

4.4.2.1 KSR Keyboard. Current flow continues from the keyswitch through a diode (connected in series with every switch), and into the enabled row (See Figure 4-16a). While current is flowing, the column output will be low. The diode prevents current flow from an unenabled row to an enabled row when two switches on the same column are actuated.

4.4.2.2 RO Keyboard. Current flow continues from the keyswitch differently depending upon whether the switch is located in the operator's keypad or in the operator control panel section of the keyboard. If the depressed switch is in the operator control section, current flow proceeds exactly as in the KSR keyboard (See Section 4.4.2.1). Otherwise, current proceeding through the keyswitch enters the enabled row immediately, but is then passed through a diode, and then to the interface. The diode in this case prevents current flow from an unenabled row to an enabled row as in the KSR keyboard, but does not allow for n-key rollover. (See Figure 4-16b).

4.4.2.3 Column Data. The output of each matrix column is fed to a voltage comparator (KSR keyboard: (U2, U3, drawing 999710, sheet 1; RO Keyboard: U2, drawing 999951, sheet 1). The reference voltage for the comparator is taken from a voltage divider, and should measure approximately 1.74 volts. The output of the voltage comparator is routed through J1 to the keyboard interface logic on the Model 820 terminal electronics PWB. The row inputs are buffered through two hex bus drivers (U7, U8, drawing 999710 (KSR), drawing 999951 (RO), sheet 1).

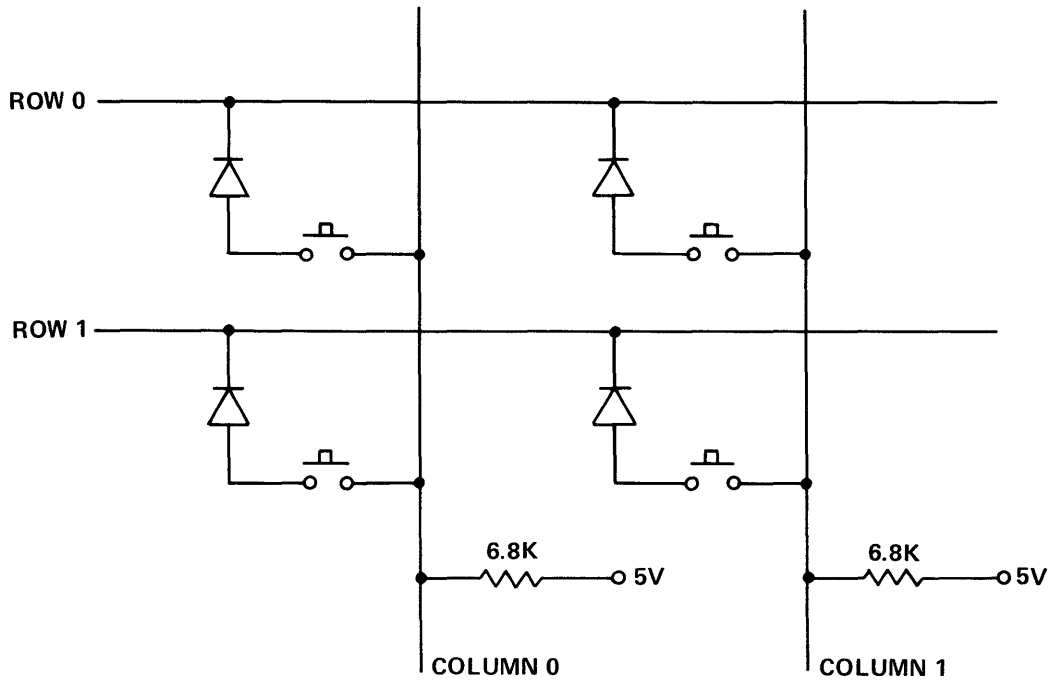

Figure 4-16a Keyboard Matrix Simplified Diagram (Model 820 KSR)

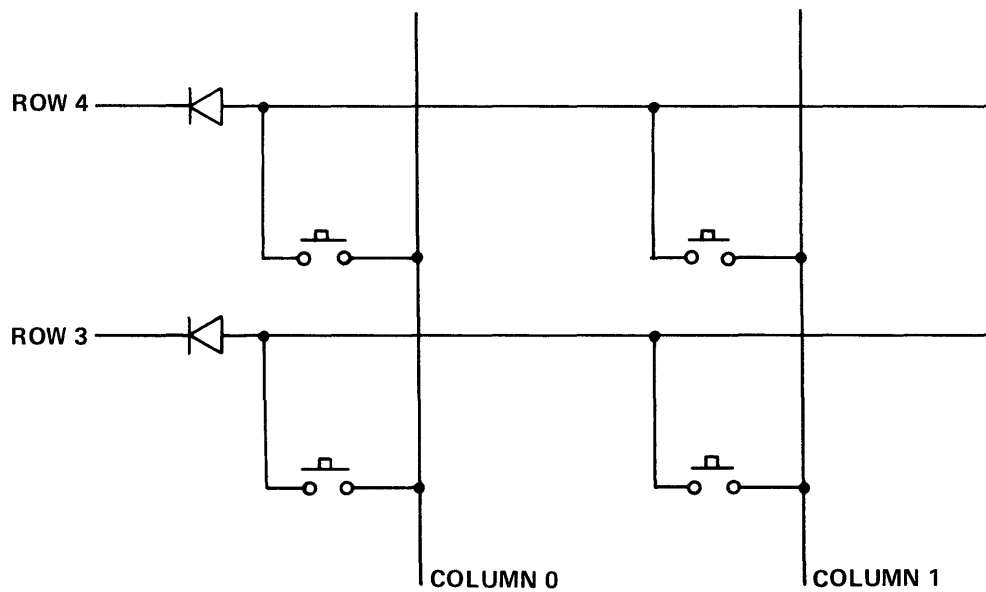

Figure 4-16b Keyboard Matrix Simplified Diagram (Model 820 RO)

4.4.3 TERMINAL STATUS DISPLAYS AND INDICATORS. the terminal status display (TSD) is controlled by rows R0-R3 and R9-R11. Outputs R9-R11 strobe the seven-segment LED displays by forward-biasing transistors Q1, Q2, and Q3. These three transistors supply the current to the common-anode segment LED diodes of the display. The display is driven by a BCD-to-seven-segment decoder/driver (U1, drawing 999710 (KSR) or drawing 999951 (R0), sheet 1). The four inputs (A-D) for the decoder/driver are R0-R3, respectively (See Figure 4-17). The other terminal indicators are controlled by R5-R7 and are activated by enabling their respective rows (low).

4.4.4 KEYBOARD INTERFACE. All references in this subsection apply to drawing 999945, sheets 7 and 8. The keyboard interface connects the data bus of the Z-80A CPU to the row inputs and column outputs of the keyboard. The keyboard interface also connects the data bus to the ribbon motor drive inputs. The data bus is an eight-bit bidirectional bus. The terminal electronics PWB, which includes the keyboard interface logic, is connected to the keyboard PWB by a 25-conductor ribbon cable (the center conductor is not used). A simplified block diagram of the keyboard PWB is shown in figure 4-18.

The row pulses are clocked out of latches U36 and U37 upon transitions of the signals /IO3 and /IO2, respectively, provided by the memory interface logic. The column data is latched into U34 by the signal /IO6. U36 also contains the ribbon motor latches, which are clocked by /IO3 along with the row pulses for rows R9-R11.

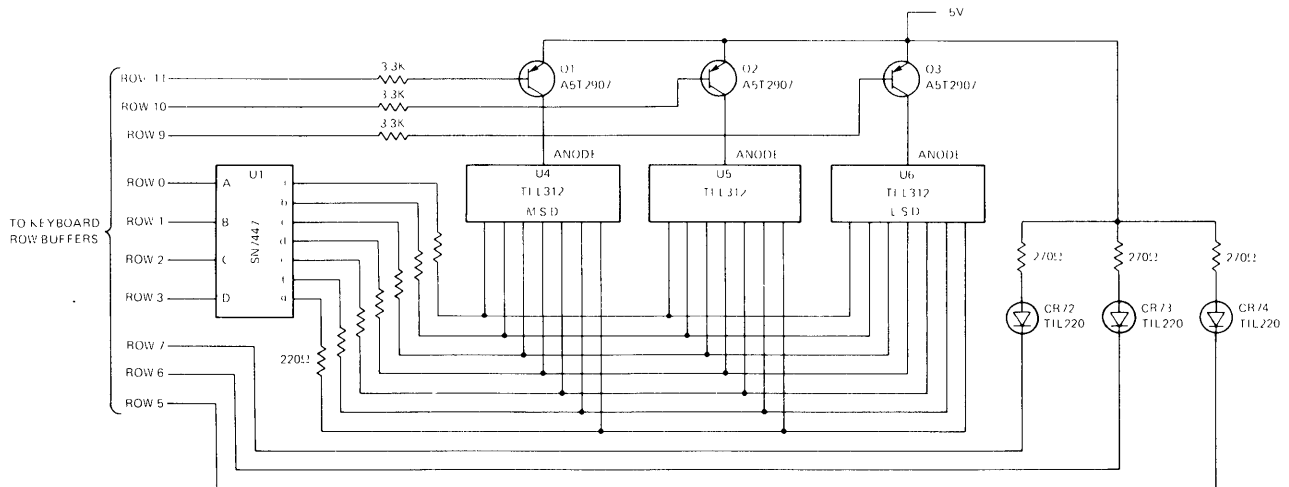

Figure 4-17 Terminal Displays, Simplified Diagram

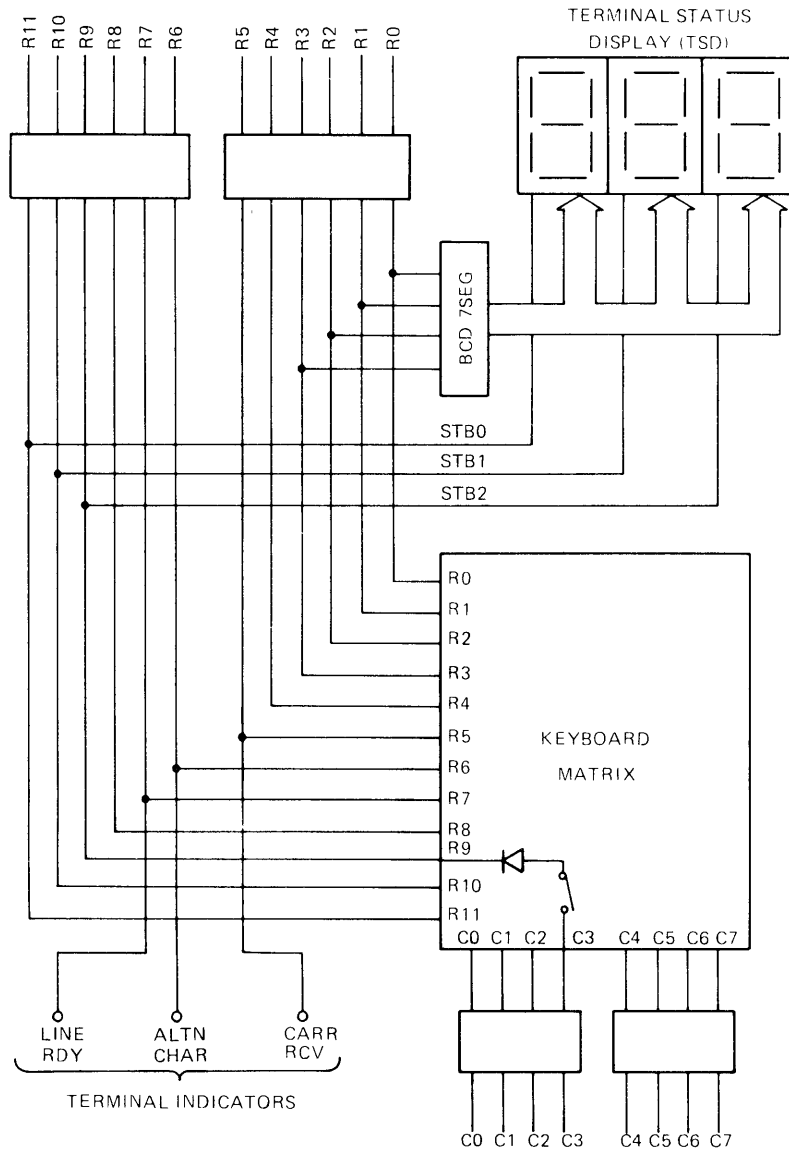

Figure 4-18 Keyboard PWB Simplified Diagram

4.5 COMMUNICATIONS INTERFACE

The communications interface, controlled by the Z-80A CPU, utilizes a Z-80A SIO (Serial I/O Controller), as well as addressable input and output latches. All communications interface *input* signals are converted from EIA/CCITT levels to TTL levels as described in EIA standard RS-232-C. The communications interface logic is shown on drawing 999945, sheet 7, and discussed in section 3.

4.5.1 INTERFACE SIGNALS. The Model 820 KSR and RO Terminals support the communication signals described in Section 3.4 of this manual. All communications interface signals are routed from the 25-pin connector mounted on the rear of the terminal electronics PWB by the internal EIA cable assembly (drawing 999972). The signals in this cable are designated by both the EIA and CCITT circuit names. For example, the received data signal is designated BB/104.

4.5.2 SIGNAL LEVEL CONVERSION. All inputs from J3 are converted from EIA/CCITT levels to TTL logic levels by the logic elements in location U43 and U44. All outputs to J3 are converted from TTL logic levels to EIA/CCITT levels by the logic elements in locations U42 and U41.

4.5.3 SERIAL I/O CONTROLLER. The Z-80A SIO (Serial I/O) Controller is a programmable, dual-channel device which provides formatting of data for serial data communication as well as some EIA RS-232-C line control. Its basic function is that of a serial-to-parallel, parallel-to-serial converter/controller, but it is adaptable enough to handle almost any serial data task. The Z-80A SIO is capable of handling both synchronous and asynchronous protocols, but in the Model 820 KSR/RO Terminals it functions only in the asynchronous mode. It is capable of generating and testing parity, interrupting the Z-80A CPU for a variety of purposes, and transmitting and receiving independently. An internal daisy chain interrupt structure allows for either vectored interrupts or a polled interrupt handler. The device requires the same +5V and Ground power supply as the Z-80A CPU, plus a system clock and a baud rate clock for both the receiver and transmitter of each channel.

The Model 820 KSR and RO Terminals make use of only one channel of the Z-80A SIO, therefore some of the devices may be marked Z-80A SIO/9, indicating only one functional channel. As stated before, only the asynchronous mode is used. The 16X clock mode is used for both the transmitted and received data clocks, and both of these signals are tied together for a common data rate for transmitted and received data. This baud clock is generated by one of the Z-80A CTC's.

The Z-80A SIO is configured to generate an interrupt to the Z-80A CPU upon receipt of a character or upon its transmit buffer becoming empty. It does not generate interrupts upon transitions of control signals (/CTSA, /DCDA). The Z-80A SIO (drawing 999945, sheet 7) is addressed as memory-mapped I/O. Control registers are written to and read from the control addresses for channels A and B, and data is inputted or outputted through the data address for channel A (see Figure 4-15). The address for channel B data is not used.

The Z-80A SIO provides the interface signals *Request to Send (RTS)* and *Data Terminal Ready (DTR)*, and is polled to determine the status of *Data Carrier Detect (DCD)* and *Clear to Send (CTS)*. All other interface signals are under direct control of the Z-80A CPU Terminal Controller, utilizing the input buffer at U33 and the output latch at U18. The character structure of transmitted and received data is shown in Figure 4-19.

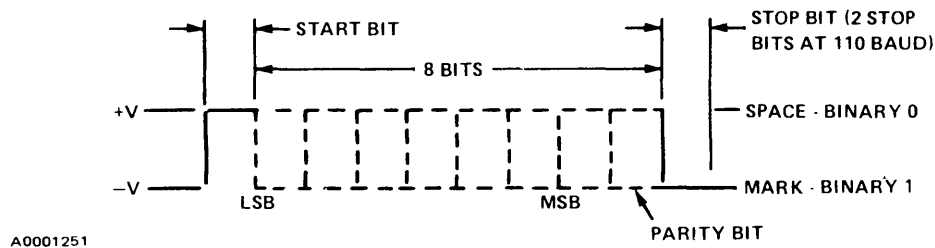

Figure 4-19 Asynchronous Data Format

4.5.4 CURRENT-LOOP (TTY) INTERFACE (Optional). An optional 20-mA current-loop interface is available for the Model 820 KSR and RO Terminals. If installed, the current-loop PWB is situated in the Model 820 option slot located in the keyboard assembly beneath the keyboard PWB. If the option is to be used, Model 820 KSR/RO Terminal should be configured to code 16.

The current-loop interface communicates to a compatible host via four lines: RCVCURIN (Received Current In), RCVCURO (Received Current Out), TXDCURIN (Transmitted Current In) and TXDCURO (Transmitted Current Out). A host system may connect to these four lines via a 9-pin receptacle located just above the EIA RS-232-C connector on the back of the Model 820 Terminals. Signals on these lines are cabled immediately to the current-loop PWB.

The current-loop interface must also interface with the Model 820 main board in order to receive and transmit data and commands. This is accomplished via the EIA connector and cable assembly in conjunction with a shorting plug to be inserted in the connector. This allows data to flow from the processor, through the communications interface, through the cable assembly, to the EIA RS-232C connector assembly, through another cable, to the current-loop interface, back through a 4-wire cable, to the optional 9-pin connector in the transmitted data path. Data flow is the reverse for received data.

The translation from serial EIA RS-232C data to current pulses is accomplished via an optical coupling network and current amplifier; similarly, received current pulses are translated to serial data via an optical coupling network and a line driver. See drawing 2206530 for more detail.

4.6 RIBBON DRIVE SUBSYSTEM

4.6.1 RIBBON MOTOR DRIVE. The terminal processor (the Z-80A CPU) also controls the speed and direction of the ribbon drive motor. The ribbon drive motor is a four-phase pulse-modulated device operated in a stepping motor, unipolar, single-phase, voltage-switched mode. The motor steps each time a different phase winding is energized. The ribbon motor drive circuit (drawing 999945, sheet 11) receives the inputs to the phase windings, ROA-ROD, from a latch (U36) connected to the buffered data bus lines of the Z-80A.

Clockwise rotation of the motor is induced by the following sequence:

$T_{cw} = ROA \quad ROB \quad ROC \quad ROD \quad ROA$

Counterclockwise rotation is obtained by the following sequence:

$T_{ccw} = ROA \quad ROD \quad ROC \quad ROB \quad ROA$

Each motor phase is switched between +33 volts and ground using a four-stage monolithic Darlington amplifier. For example, motor detent at RPHSA is achieved with ROA at a logic ONE. Current is sourced to the base of the Darlington at input pin 6. The emitter-to-base (V_{BE}) of the Darlington clamps at approximately 1.5 volts.

When saturated, the Darlington switch clamps the output (pin 7) to approximately 1 volt. When logic input ROA is returned to a logic ZERO, the Darlington is switched off and inductive flyback diode is clamped at approximately 1 volt above the supply voltage. The magnetic detent will maintain the rotor at RPHSA detent until one of the phases is energized.

4.6.2 RIBBON MOTOR DIRECTION. Ribbon motor direction is determined by the order in which the phase windings are energized. The ribbon mounted on the ribbon drive continues to move in one direction until the ribbon supply reel is almost empty, at which time an eyelet in the ribbon actuates the ribbon reverse switch (RIBREVSW) located on the ribbon drive deck. When the switch is actuated, a signal is applied to a Schmitt trigger (drawing 999945, sheet 7) which is buffered by U33 and polled by the Z-80A CPU. When the software detects RIBREVSW switch actuation, it reverses the order in which the phase windings of the ribbon motor are energized and the motor reverses direction.

4.7 PAPER DRIVE SUBSYSTEM

4.7.1 PAPER MOTOR DRIVER CIRCUIT. Paper motion, like almost all other Model 820 KSR and RO Terminal functions, is controlled directly by the CPU (via an intermediate latch). The paper motor is a four-phase, permanent magnet stepping motor. The speed of the motor is determined by the speed at which the phase signal input (POA-POD) from the CPU causes the motor to step. Motor direction is determined by the order in which the motor phase windings are enabled. Each eight steps of the motor will cause the paper

(form) to advance (or reverse) one line in 6 LPI mode; six steps will cause the paper (form) to advance (or reverse) one line in 8 LPI mode.

The phases are enabled in pairs for stepping motion. When a phase line goes high, it switches on the appropriate transistor which supplies current to the selected phase winding in the motor. The current enters the motor through pins 1 through 4 of J104 and returns through pins 1, 3, 4, and 5 of J106 (drawing 999945, sheet 10). For example, phase A and phase B are both on; after a period of time determined by the terminal controller, phase A is switched off and phase C is switched on. The motor rotates one step at that time. When phase B is switched off, phase D is switched on, producing another motor step.

When the motor is not stepping, a detent or holding torque is required to lock the motor at the position at which it stops. The detent signal is enabled by the PDMCC (paper drive motor current control) line from the latch U6, which is set by the Z-80A CPU. By applying a low current to the two-phase windings of the stepper motor enabled by the phase signal input from the printer controller, the stepper motor is electrically "locked" into the last stepped position. When the PDMCC line is disabled, the current through the selected phase windings will return to the higher stepping level, and the stepping motor will begin to step when the phase signals begin to change.

The paper motor drive operates as a current-controlled, switching mode regulator in an integrated choke circuit configuration. The circuit consists of a current-sensing comparator U113; motor phase selector Q116, Q114, Q117, or Q115; and a power switch Q113. When PDMCC is low, a detent motor current is established; when PDMCC is high, the motor current is increased to a level sufficient to develop motor torque to meet the worst-case friction torque. Clockwise rotation is induced by the following sequence (based on single-phase drive):

T_{cw} = POA POB POC POD POA

Counterclockwise rotation is induced by the following sequence:

T_{ccw} = POA POD POC POB POA

For example, after power becomes good the +5VSW signal goes high and one or more motor phases can be selected. If POA is high, the Darlington transistor Q116 is switched on, which switches on transistor Q119, causing Q113 to switch on and saturate. This causes current to be input to motor windings PDRV and out PPHSA, where it is sunk by transistor Q116. When sufficient motor current is flowing, the voltage developed across resistor R133 will cause the comparator to change states, causing U113-7 to go low. This action switches off Q119 which removes the base drive from Q113. Motor current will now flow from the anode of CR116, through PDRV, through PPHSA, through Q116 and sense resistor R133. The circuit exhibits a long recovery time in this mode. As the current flowing through R133 decays, the voltage drop across R133 decreases until, eventually, the comparator will return to the original state, permitting U113-7 to go high, which switches on Q119 and Q113.

The loop continues operating in a self-oscillating, chopping mode as long as one of the phase-select inputs is enabled. As in the above example in which Q116 is switched off, Q113 switches off, providing the motor windin inductance a fast recovery path through CR116, through PDRV, through PPHSA, the zener CR117, CR132, and through CR124. Circuit operation is similar for any of the other selected phases. If more than one phase is selected at a time, the current will divide approximately equally through the windings.

4.7.2 PAPER-OUT DETECTION. When the paper-out switch (PAPOUTSW) in the printing mechanism is actuated, indicating that there is no paper in the mechanism, a Schmitt trigger (U1B) provides an input to the buffer at U33 (drawing 999945, sheet 7). The paper-out signal is then read by the Z-80A CPU, which rings the bell and displays an error code on the terminal status display. Operation cannot be restored until the switch is opened; that is, paper is installed in the mechanism.

4.8 PRINthead CARRIAGE DRIVE

4.8.1 PRINthead POSITIONING. The Z-80A CPU Terminal Controller does all of the calculations and manipulations necessary to move the printhead carriage of the Model 820 KSR and RO Terminals. The CPU accepts position data from the encoder attached to the carriage motor and responds by sending to motor drive circuits one of four possible acceleration commands. Motor direction is selected by the CMFWD (carriage motor forward) line emanating from output latch U6 (drawing 999945, sheet 8). The acceleration of the motor is determined by the ACC1 and ACC2 lines; these two lines provide four possible combinations of acceleration commands. Since carriage motor acceleration is a function of motor current, the acceleration signals cause the motor driver circuit to act as a selectable, constant-current source for the carriage motor. Table 4-1 lists the current output of the motor driver circuit for all four acceleration combinations.

When the carriage motor is running, the Z-80A CPU operating system is responsible for maintaining the appropriate motor speed for the function being performed. By comparing the time between tachometer signals with a reference time (supplied by a CTC device), the CPU determines which acceleration signals are required to maintain correct printhead travel speed and issues the appropriate commands.

Motor speed and digital direction control signals from the printer controller are converted to analog drive signals by the Model 820 carriage motor drive circuit (drawing 999945, sheet 9). Motor direction is changed by reversing the motor voltage polarity with the CMFWD line. When the CMFWD line is high (logic ONE), driver transistor Q105 is switched on and driver transistor Q106 is switched off. If the CMFWD line is low (logic ZERO, indicating a reverse motor command, Q105 is off and Q106 is on.

TABLE 4-1. MOTOR DRIVER ACCELERATION CONTROL OUTPUT

ACC1	ACC2	MOTOR CURRENT (AMPERES)
0	0	0.00
0	1	0.66
1	0	1.43
1	1	2.86

The carriage motor driver circuit is a constant-current switching regulator. Current for the carriage motor, when it is moving the printhead forward (left to right), is supplied by the +33 volt motor supply, through Q108 (which has been switched ON by Q105), through motor winding (CMTRA to CMTRB), and to the motor return line via Q110 and current sensing resistor R125. If the motor is commanded to travel in the reverse direction (right to left), the current path is now through Q109, the motor winding (CMTRB to CMTRA), Q111, and to sensing resistor R125. The appropriate current path is selected by the CMFWD line.

The current sensing resistor R125 produces an output proportional to the amount of current passing through it. As the amount of current passing through R125 increases, the voltage drop across it increases. This change is level shifted and input to pin 2 of voltage comparator U113. The acceleration signals from the Z-80A CPU provide a different reference to voltage comparator U113 for each combination received. The output of this comparator controls transistor Q107 to provide current regulation switching from the carriage motor.

The motor draws current through current sense resistor R125 until the voltage drop across it produces a difference signal into comparator U113. When this occurs, Q107 is switched off which switches off the driver transistor (Q105 is forward direction or Q106 if reverse direction). When the current is switched OFF, the voltage drop across R125 decreases and comparator U113 switches Q107 back ON. This, in turn, switches

ON the appropriate driver transistor, and the drive voltage is again applied to the carriage motor. The result is a constant-current source which is regulated by the voltage reference selected by the Z-80A CPU acceleration signals.

The carriage motor is coupled with an optical tachometer assembly mounted on the rear of the motor casing. The tachometer assembly is an integral part of the motor and cannot be removed. The tachometer optoelectrics are supplied with a +5 volt supply through J8 (drawing 999945, sheet 1). The outputs of the normal print tachometer are TOA1 and TOB1 which are fed to Schmitt trigger circuits and through the compressed print option selection logic. The outputs of the compressed print tachometer are TOB1 and TOB2, which are handled similarly. The clock signal /CLK gates the tachometer pulses into latch U7 and PROM U8. The resulting output is a pulse on the SENSOR line that represents 0.2158 mm (8.33 mils) of printhead movement in normal (not compressed print) mode and a signal (DIRECT) line indicates printhead travel from left to right when high, and travel from right to left when low.

The Z-80A CPU Terminal Controller maintains a printhead position counter in its internal RAM. Each time the SENSOR line is pulsed, the Z-80A CTC at U21 (drawing 999945, sheet 7) counts down to zero and generates an interrupt. The interrupt handler software then increments or decrements (depending on the direction of motion of the printhead) the register containing the printhead position and resets the counter in the Z-80A CTC to 1 for the next movement of the printhead.

The CPU initially determines (upon power-up) printhead position by moving the printhead to the left bumper, and then advancing to the left margin. Once the printhead has positioned itself at the left margin, the terminal controller uses the tachometer feedback from the carriage motor to determine where the printhead is at any given time.

When the terminal is powered-up the terminal controller must assume the printhead has been able to move to the left margin.

NOTE

If the printhead is obstructed when the terminal is powered-up, the terminal controller will assume the position where the printhead stopped is the left bumper. This will cause all future printhead position information to be incorrect. If this occurs, remove the obstruction and cycle the power off and on.

4.8.2 CARRIAGE JAM DETECTION. The determination that a jammed carriage has occurred will be made in the following manner by the Z-80A CPU Terminal Controller. If the carriage motor receives acceleration signals from the CPU to begin (or continue) movement of the printhead, a timer is started, and monitoring of the sensor pulses from the carriage motor tachometer and interface logic is begun. If the CPU does not receive sensor pulses within a specified time, a carriage jam is judged to have occurred, and the appropriate error code is displayed on the TSD to the accompaniment of one second audible tone, which alerts the operator to the error.

NOTE

If the carriage/paper motor fuse is not present or blown at the time of power-up or during operation, a carriage jam will be indicated and cannot be cleared until the fuse (F103, drawing 999945, sheet 9) is replaced.

4.9 CHARACTER PRINTING

The Z-80A Terminal Controller CPU, in its operating system processing, determines which characters in incoming data streams are to be printed and where they are to be printed. This operating system decodes

these characters and generates a set of sequential addresses to be applied to the character generator ROM loaded in socket XU12 (drawing 999945, sheet 5). Each address is then selected by the Z-80A CPU address lines (A0-A11), producing an eight-bit digital word at the output of the character ROM. The output of the character ROM is then routed back through the CPU via the Z-80A CPU data bus and gated into latch U27. The data is then transferred into latch U15 with each pulse of the SENSOR line. After the contents have been in U15 for 400 microseconds, the latch is cleared by the line CLRDOTS.

The eight-bit digital output of the latch makes up one of the nine columns used to create a character by the impact printhead. Each character is composed of nine seven-dot columns as illustrated in Figure 4-20. As the printhead travels along the form, each column is printed until all nine columns for each character are printed. The dot patterns for characters are illustrated in Appendix A. Dot patterns used with the various international keyboard options are also shown in Appendix A.

The eight-bit digital output of the latch (SF1-SF8) is sensed by the printhead driver circuit (drawing 999945), sheet 12) which closes the path for the selected solenoids in the printhead. Each transistor (U102 and U103) acts a switch for a solenoid in the printhead. Each solenoid controls one wire of the seven in the printhead.

When an input is enabled, the circuit is closed and the selected wire impacts the printing paper through the ribbon. The eighth input to the printhead driver (SF8) is an enabling line and must be enabled for the printhead to function. Each time a column is to be printed the SF8 line must be enabled. Current regulation for the printhead solenoids is provided by transistors Q101 through Q104 with comparator U107 providing current regulation switching control to Q104. Diodes CR105 through CR111 provide flyback protection from the printhead solenoids when the circuit is opened.

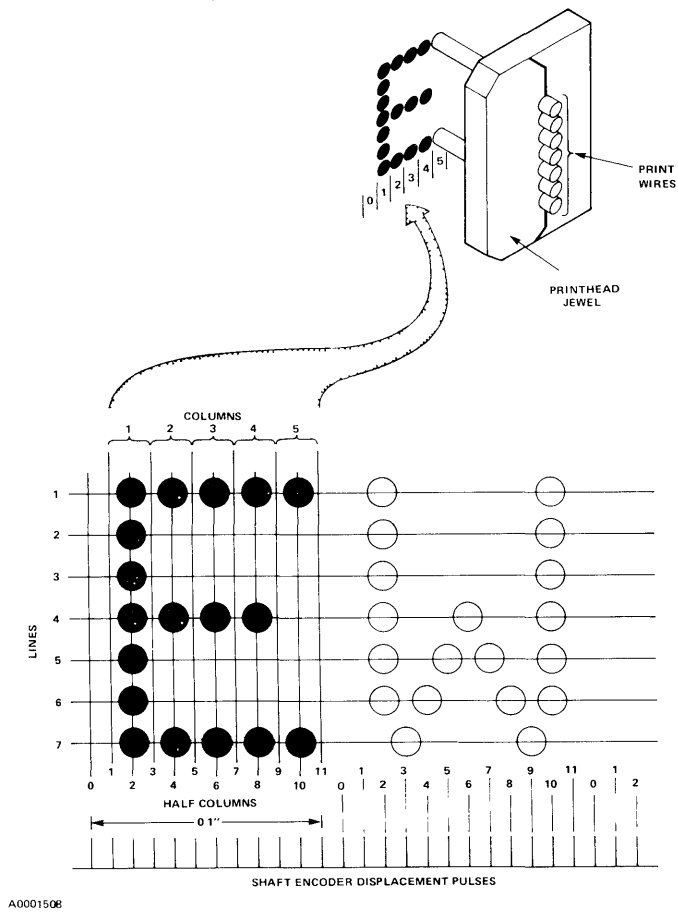

Figure 4-20 Printing the Letter "E"

SECTION V

PREVENTIVE MAINTENANCE AND SELF-TEST PROCEDURES

5.1 INTRODUCTION

This section describes cleaning and lubricating procedures the operator should perform to maintain the Model 820 RO in optimum operating condition. The operator should not attempt to repair or replace parts and assemblies such as the printhead, paper handling mechanism, keyboard, etc. Instead, refer qualified technicians to the Model 820 RO/KSR Maintenance Manual (TI Manual No. 2206552-9701) for maintenance procedures, schematics, and assembly drawings.

5.2 PREVENTIVE MAINTENANCE

The Model 820 RO terminal is designed to provide reliable service with a minimum of operator maintenance. In order to maintain the highest level of operation, the following procedure should be followed once each month.

WARNING

Set the terminal ON/OFF switch to OFF and remove the power cord from the terminal in order to avoid electrical shock hazards.

- a. Switch terminal power to OFF and remove the power cord.
- b. Lift the cover and carefully vacuum the paper chaff from the printhead and ribbon path areas (see Figure 10-1).

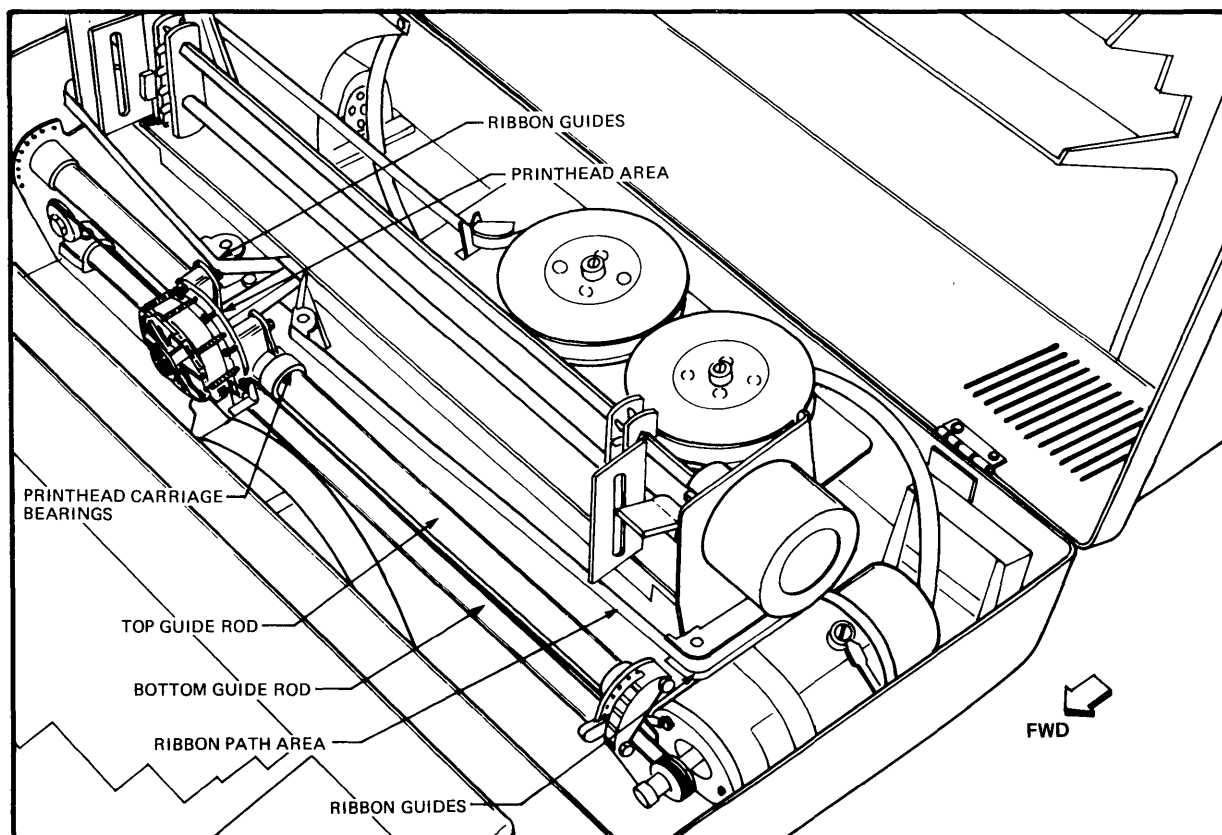

Figure 5-1. Printhead Area, Guide Rods, and Ribbon Guide

5.3 SELF-TESTS

The Model 820 Terminals provide automatic self-test functions to verify correct terminal operation. Two types of self-tests are built into the Model 820 KSR and RO Terminals:

- Power-up diagnostic tests
- Maintenance tests.

5.3.1 POWER-UP DIAGNOSTIC TESTS. The following sequence of tests is performed automatically by the Model 820, in the order indicated, each time power is applied to the terminal.

5.3.1.1 Indicator Test. The indicator test is initiated at the beginning of the power-up sequence. The LED indicators switch on, and the terminal status display (TSD) shows 888. The indicator test continues until the power-up sequence is complete (approximately two seconds).

5.3.1.2 RAM Test. The terminal main processor exercises its random access memory (RAM) to verify that data can be written to (recorded) and read (played back) from each memory location. A checkerboard pattern is written and read, followed by writing and reading of an inverted checkerboard pattern. If an error is detected, a RAM failure error code is activated and is displayed on the TSD. The processor proceeds to the next test, but there is no assurance that subsequent test results are valid if this test fails. (Note: a small portion of the RAM, required to execute the test program, is not tested by the checkerboard pattern).

5.3.1.3 ROM Test. The terminal controller performs a cyclic redundancy character (CRC) check of its standard read-only memory (ROM), plus any installed optional ROM's. The character generator (dot table) ROM is not tested. If the result of the CRC test is unsatisfactory, a ROM failure error code is activated and displayed on the TSD. The processor proceeds to the next test, but subsequent test results may not be valid if this test fails.

5.3.1.4 Nonvolatile Memory Test. The terminal controller computes the checksum of the contents of the nonvolatile memory (configuration and format parameters). If an error is found, the processor reloads the configuration memory with default configuration and format parameters, and a nonvolatile memory error code is activated and displayed.

5.3.1.5 Audible Tone Test. Upon completion of the memory tests and memory initialization, the audible tone is sounded for 80 milliseconds. The terminal controller then executes a power-up sequence. The last portion of the sequence causes the printhead to align to the left margin.

If any power-up test failures occurred, the audible tone will sound for 1 second, and the appropriate error code(s) will be displayed in the TSD. In either case the LED indicators assume their normal status.

5.4 MAINTENANCE TESTS

The maintenance tests must be manually initiated from the keyboard. Three maintenance tests may be performed on the standard Model 820 KSR terminal:

- BARBERPOLE test
- RUN-IN test
- COMMUNICATIONS test

If the Model 820 KSR is equipped with an alternate character set option, it is possible to perform an.

- ALTERNATE CHARACTER SET BARBERPOLE test

Two maintenance tests may be performed on the standard Model 820 RO terminal, in addition to the optional ALTERNATE CHARACTER SET BARBERPOLE test pattern. These are:

- BARBERPOLE test
- RUN-IN test

5.4.1 BARBERPOLE TEST. The barberpole test causes the printer mechanism to print all 95 characters of the standard character set in a repetitive “barberpole” pattern at maximum print speed. The pattern is printed within the defined margins.

To exercise the terminal logic to the fullest extent possible, the test pattern is generated by the terminal controller, transmitted, and looped back internally (inside the EIA interface circuits and any optional line interface) from the terminal transmitter output to the terminal receiver input before printing.

The barberpole test may be initiated using the following procedure:

Model 820 KSR	Model 820 RO
a. Set the LINE/•/LCL switch to LCL.	a. Set the LINE/•/LCL switch to LCL.
b. <i>Simultaneously</i> press the CTRL , SHIFT , and 1 keys. The terminal will respond by printing the barberpole pattern displaying a status code 39 (test in progress) on the TSD.	b. <i>Sequentially</i> press the TEST and 1 keys. The terminal will respond by printing the barberpole pattern and displaying a status code 39 (test in progress) on the TSD.
c. Terminate the test by pressing the RESET key.	c. Terminate the test by pressing the RESET key.

Figure 5-2 shows an example of the barberpole test in standard (10 CPI) and compressed (16.5 CPI) character spacing.

-. /0123456789:;<=>?@ABCDEFGHIJKLMNopQRSTUVWXYZ[\]^_`abcdefghijklmnopqr
. /0123456789:;<=>?@ABCDEFGHIJKLMNopQRSTUVWXYZ[\]^_`abcdefghijklmnopqrs
/0123456789:;<=>?@ABCDEFGHIJKLMNopQRSTUVWXYZ[\]^_`abcdefghijklmnopqrst
0123456789:;<=>?@ABCDEFGHIJKLMNopQRSTUVWXYZ[\]^_`abcdefghijklmnopqrstu
123456789:;<=>?@ABCDEFGHIJKLMNopQRSTUVWXYZ[\]^_`abcdefghijklmnopqrstuv
23456789:;<=>?@ABCDEFGHIJKLMNopQRSTUVWXYZ[\]^_`abcdefghijklmnopqrstuvw
3456789:;<=>?@ABCDEFGHIJKLMNopQRSTUVWXYZ[\]^_`abcdefghijklmnopqrstuvwx
456789:;<=>?@ABCDEFGHIJKLMNopQRSTUVWXYZ[\]^_`abcdefghijklmnopqrstuvwxy
56789:;<=>?@ABCDEFGHIJKLMNopQRSTUVWXYZ[\]^_`abcdefghijklmnopqrstuvwxyz
6789:;<=>?@ABCDEFGHIJKLMNopQRSTUVWXYZ[\]^_`abcdefghijklmnopqrstuvwxyz{
789:;<=>?@ABCDEFGHIJKLMNopQRSTUVWXYZ[\]^_`abcdefghijklmnopqrstuvwxyz{!
89:;<=>?@ABCDEFGHIJKLMNopQRSTUVWXYZ[\]^_`abcdefghijklmnopqrstuvwxyz{!
9:;<=>?@ABCDEFGHIJKLMNopQRSTUVWXYZ[\]^_`abcdefghijklmnopqrstuvwxyz{!}~
:;<=>?@ABCDEFGHIJKLMNopQRSTUVWXYZ[\]^_`abcdefghijklmnopqrstuvwxyz{!}~
:;<=>?@ABCDEFGHIJKLMNopQRSTUVWXYZ[\]^_`abcdefghijklmnopqrstuvwxyz{!}~

A. STANDARD PRINTING TEST

-. /0123456789:;<=>?@ABCDEFGHIJKLMNopQRSTUVWXYZ[\]^_`abcdefghijklmnopqrstuvwxyz{!}~ !"\$%&'()*+,-./0123456789:;<=>?@A
. /0123456789:;<=>?@ABCDEFGHIJKLMNopQRSTUVWXYZ[\]^_`abcdefghijklmnopqrstuvwxyz{!}~ !"\$%&'()*+,-./0123456789:;<=>?@AB
/0123456789:;<=>?@ABCDEFGHIJKLMNopQRSTUVWXYZ[\]^_`abcdefghijklmnopqrstuvwxyz{!}~ !"\$%&'()*+,-./0123456789:;<=>?@ABC
0123456789:;<=>?@ABCDEFGHIJKLMNopQRSTUVWXYZ[\]^_`abcdefghijklmnopqrstuvwxyz{!}~ !"\$%&'()*+,-./0123456789:;<=>?@ABCD
123456789:;<=>?@ABCDEFGHIJKLMNopQRSTUVWXYZ[\]^_`abcdefghijklmnopqrstuvwxyz{!}~ !"\$%&'()*+,-./0123456789:;<=>?@ABCDE
23456789:;<=>?@ABCDEFGHIJKLMNopQRSTUVWXYZ[\]^_`abcdefghijklmnopqrstuvwxyz{!}~ !"\$%&'()*+,-./0123456789:;<=>?@ABCDEF
3456789:;<=>?@ABCDEFGHIJKLMNopQRSTUVWXYZ[\]^_`abcdefghijklmnopqrstuvwxyz{!}~ !"\$%&'()*+,-./0123456789:;<=>?@ABCDEFG
456789:;<=>?@ABCDEFGHIJKLMNopQRSTUVWXYZ[\]^_`abcdefghijklmnopqrstuvwxyz{!}~ !"\$%&'()*+,-./0123456789:;<=>?@ABCDEFGH
56789:;<=>?@ABCDEFGHIJKLMNopQRSTUVWXYZ[\]^_`abcdefghijklmnopqrstuvwxyz{!}~ !"\$%&'()*+,-./0123456789:;<=>?@ABCDEFGHI
6789:;<=>?@ABCDEFGHIJKLMNopQRSTUVWXYZ[\]^_`abcdefghijklmnopqrstuvwxyz{!}~ !"\$%&'()*+,-./0123456789:;<=>?@ABCDEFGHIJ
789:;<=>?@ABCDEFGHIJKLMNopQRSTUVWXYZ[\]^_`abcdefghijklmnopqrstuvwxyz{!}~ !"\$%&'()*+,-./0123456789:;<=>?@ABCDEFGHIJKI
89:;<=>?@ABCDEFGHIJKLMNopQRSTUVWXYZ[\]^_`abcdefghijklmnopqrstuvwxyz{!}~ !"\$%&'()*+,-./0123456789:;<=>?@ABCDEFGHIJKL
9:;<=>?@ABCDEFGHIJKLMNopQRSTUVWXYZ[\]^_`abcdefghijklmnopqrstuvwxyz{!}~ !"\$%&'()*+,-./0123456789:;<=>?@ABCDEFGHIJKLM
:;<=>?@ABCDEFGHIJKLMNopQRSTUVWXYZ[\]^_`abcdefghijklmnopqrstuvwxyz{!}~ !"\$%&'()*+,-./0123456789:;<=>?@ABCDEFGHIJKLMN

B. COMPRESSED PRINTING TEST

Figure 5-2. Normal Results of Barberpole Test

5.4.1.1 Alternate Character Barberpole Test. An alternate character barberpole pattern may be generated by either the Model 820 KSR or RO if it is equipped with an alternate character set option. This test is generated exactly like the standard barberpole test, except that the alternate character set is substituted for the standard ASCII set. The test may be begun in the following manner:

Model 820 KSR

- a. Set the LINE/●/LCL switch to LCL.
- b. Switch the terminal to alternate character set operation by typing in **CTRL** **Q** simultaneously.
- c. Proceed as with ordinary barberpole test. An alternate character set barberpole pattern will be printed, and status code 39 will flash in the TSD.
- d. Terminate the test by pressing the **RESET** key.

Model 820 RO

- a. Set the LINE/●/LCL switch to LCL.
- b. Sequentially press the **TEST** and **Q** keys. The terminal will respond by printing an alternate character set barberpole pattern, and flashing a status code 39 in the TSD.

NOTE

If no alternate character set option is installed, the Model 820 RO will print an ordinary barberpole pattern.

- c. Terminate the test by pressing the **RESET** key.

5.4.2 RUN-IN TEST. The run-in test is generated in much the same manner as the barberpole test, and is designed to test both the communications processing and (with special emphasis) the carriage mechanism. The run-in test functions as it was intended only with 132-column print widths. It generates the following pattern on the first pass of each printed line:

O backspace space K backspace space O backspace space K backspace K

This pattern is immediately overprinted (high-speed, without backspaces and spaces) from right to left, and a new pattern is begun on the next line.

The run-in test is initiated by substituting CTRL SHIFT 6 for CTRL SHIFT 1 in the barberpole test procedure for the Model 820 KSR, and by substituting TEST 6 for TEST 1 in the barberpole test procedure for the Model 820 RO.

NOTE

If a print width other than 132 columns is selected, the run-in test will not perform properly.

5.4.3 COMMUNICATIONS TEST (KSR Only).

5.4.3.1 Using the EIA Plug.

NOTE

This test helps to isolate communications problems whether within the Model 820 KSR terminal or outside the terminal.

The communications system of the terminal can be tested by using a test plug that connects to the EIA port in the rest of the terminal. The plug accepts the signals from the transmit side of the terminal and returns the same signals to the terminal receiver. The procedure for using the test plug is as follows:

- a. Set the CONFIGURE/OPERATE switch (on the keyboard under the terminal cover) to CONFIGURE and verify that the following terminal parameters are set:
 - Full duplex reverse channel ON for ready (configuration code 14)
 - Baud — any baud rate.
- b. Set the CONFIGURE/OPERATE switch to OPERATE.
- c. Insert the test plug (TI part number 999925-0001) into the communications interface connector at the rear of the terminal. Switch the LINE/●/LCL switch to LINE position.
- d. Type any printable characters on the keyboard.
- e. The terminal should print the text that is typed; if it does, the communications system (EIA portion) is functioning normally.

5.4.3.2 Acoustic Coupler Transmit Level Adjustments. The communications test initiates a signal pattern to test the communications line. When the test is initiated, pressing any code generating key on the keyboard will cause the terminal to transmit the corresponding code continuously until another key is pressed or the test is terminated. The character is transmitted at the configured baud rate (speed). The procedure for initiating and terminating the test is described below:

- a. Set the LINE/●/LCL switch to LINE.
- b. Simultaneously press the **CTRL** , **SHIFT** , and **2** keys. The terminal will respond by displaying status code 39 (test in progress) on the TSD.
- c. Press any code generating key on the keyboard. If different characters are required during the test, simply press the key for the new character desired. Each time a character key is pressed, the terminal will terminate transmission of the current character and begin to transmit the new character.
- d. To terminate the test, momentarily press the **RESET** key: The display on the TSD will resume its normal indication.

NOTE

If parameter 82 is enabled at the time the communications test is begun, the transmitted data will be printed by the Model 820 KSR. If the baud rate is set faster than 1200 baud (parameters 26, 27, or 28), the printer will not be able to print the incoming characters fast enough, thus the receive buffer will overflow, an audible tone will sound, and error code 23 will flashed in the TSD.

5.4.4 CONFIGURATION REPORT. This test provides a printed report of the current terminal configuration. The configuration report may be initiated as detailed in Section 2.9.9.

5.4.5 ROM IDENTIFICATION REPORT. This maintenance test provides a printed report which identifies the ROM's installed in the Model 820 data terminals. The ROM identification report may be initiated as follows:

Model 820 KSR

- a. Set the LINE/●/LCL switch to LCL.
- b. Simultaneously press the **CTRL**, **SHIFT**, and **4** keys

Model 820 RO

- a. Set the LINE/●/LCL switch to LCL
- b. Sequentially press the **TEST** and **4** keys.

The terminal will respond by printing:

NNA/NNA/NNA or NNA/NNA

The term **NN** is a two-digit (decimal) dash number for the ROM (stored in one byte of the ROM) The term **A** is the revision letter of the ROM obtained from a code stored in one byte of the ROM. If the DFC-option ROM is installed, the final **NNA** term will be printed; if the DFC option ROM is not installed, it will not be printed

5.5 TROUBLESHOOTING

The following outline is intended to aid in identifying malfunctioning terminal *assemblies*. It is intended as a guide for servicemen rather than a component-level repair guide. The outline is organized as a number of problem situations and their probable solution procedures, from the most debilitating problem down to the more minor ones.

- **PROBLEM: Terminal Appears Dead Upon Power-Up**
 - 1) Check power cord for wear. Replace if necessary. Check for proper mating with the terminal receptacle.
 - 2) Is power getting beyond the switch assembly to the cabling leading to the main PWB? If not, the terminal has possible switch or cabling problems. Replace if necessary.
 - 3) Power gets to line fuse F250 but not through it. Check for blown 3A fuse (3AG LIT 312003) Check fuse connections.
 - 4) Check E271 and E281 connections.
 - 5) Probable areas of failure: Line Fuse, Power Cord, Main PWB.
- **PROBLEM: Terminal Has Power, But Does Not Do Carriage Align**
 - 1) Try pressing RESET key to clear carriage jam if status code 11 is flashing in the TSD.
 - 2) Check the wire rope for wear, defects, or improper assembly. Replace if necessary. Check the capstan for damage.
 - 3) Check the ribbon for twisting. This can cause carriage jams from excessive friction.
 - 4) Check carriage motor connections (J105 and J8).
 - 5) Probable areas of trouble: Main PWB, carriage motor, connections.
- **PROBLEM: Terminal Has Power, Display Shows Other Than `||||` During Carriage Align**
 - 1) Display = `||||`. Ram failure. Check seating of U2 and U3 in sockets.

- 2) Display = 301 . ROM/PROM failure. Check seating of U9, U10, and U23 (if so equipped in sockets).
 - 3) Display = 302 . DFC ROM failure. Check seating of U12 (if so equipped) in socket. Replace if necessary.
 - 4) Display = 303 . CMOS RAM failure. Check battery and battery connections. Replace if necessary. Otherwise, CMOS RAM's are at fault.
 - 5) Display blank or any other condition. Check keyboard connections for proper seating. Replace keyboard if necessary.
 - 6) Probable areas of trouble: Main PWB, keyboard, connections.
- PROBLEM: Print Quality Substandard
 - 1) Light Print or Missing Dots: Check printhead to platen adjustment and ribbon nose guide adjustment.
 - 2) Light Print: Check ribbon for wear. Replace if necessary.
 - 3) Missing Dots (same dots in each character): Probable printhead driver problems. Replace main PWB.
 - 4) Missing Characters: Main PWB replacement indicated.
 - 5) Moving carriage but not printing dots: Probable printhead fuse or driver problems. Replace main PWB. Try reseating processor (U20) and dot ROM (U11) first.
 - 6) Probable areas of trouble: ribbon, adjustments, main PWB.
 - PROBLEM: Paper Feed Malfunctions
 - 1) No paper feed, but carriage motor works OK. Check connections J6 and J106.
 - 2) No paper feed and no carriage motion. Probable blown carriage/paper motor fuse. Replace main PWB.
 - 3) Check keyboard connections to main PWB, especially if terminal line feeds OK from the communications line, but not from the keyboard.
 - 4) Probable areas of trouble: paper motor, main PWB, connections, keyboard.
 - PROBLEM: Ribbon Drive Inoperative
 - 1) Check ribbon connections J6 and J101.
 - 2) Check to see if the ribbon is tangled around spools, twisted, or not fed through ribbon guides correctly. This can cause high friction and thus lead to motor stalling and/or burn out.
 - 3) Probable areas of trouble: connections, main PWB, ribbon motor.

- **PROBLEM: Unit Overheats, Fan Dysfunction**
 - 1) Check fan connection J203
 - 2) Check for frozen fan motor. Replace if necessary.
 - 3) Probable areas of trouble: connections, fan motor assembly, main PWB.
- **PROBLEM: Printhead Stops Moving**
 - 1) Check XU17 plug connector and sensor (J8) connections.
 - 2) Clean carriage rods.
 - 3) Check carriage motor connections (J105).
 - 4) Check printhead to platen adjustment.
 - 5) Probable areas of trouble: main PWB, connections, carriage motor assembly.
- **PROBLEM: Erratic Operation (Characters printed without keys being depressed, ribbon runs continuously, LED's flicker, paper feeds continuously, etc.)**
 - 1) Check all ground connections on keyboard and main PWB.
 - 2) Check seating of U9, U10, and U20 in sockets
 - 3) Probable areas of trouble: main PWB, grounds

NOTE

The Model 820 *must* be grounded properly for proper operation! See Section 5.6 for details on grounding.

- **PROBLEM: Paper Feeds Out of Tractors**
 - 1) Adjust lateral tension (Right hand tractor).
 - 2) Check paper box alignment with paper chute.
 - 3) Probable areas of trouble: adjustments, alignment, tractor assembly.
- **PROBLEM: Terminal On Line, Receives or Transmits Bad Data**
 - 1) Check configuration for compatibility with host system and/or data sets.
 - 2) Perform BARBERPOLE and RUN-IN tests. Does terminal print OK?

NOTE

Barberpole and Run-in tests run data from the processor through the transmitter, through a loopback device, back through the receiver, and back to the processor. If terminal fails either test, the problem is on the main PWB. Try reseating the processor (U20), the ROM's (U9 and U10), the CTC's (U21 and U22), the RAM's (U2 and U3), and especially the SIO device (U32). If this has no effect, replace the PWB.

- 3) If terminal does BARBERPOLE and RUN-IN tests OK, insert the loopback plug (999925) into the EIA connector on the rear of the machine. Reconfigure to code 09, then code 14. Switch the Model 820 online.

Do the LED's light on the front panel? If not, or if one flashes, the problem is either: a) the main PWB, b) the EIA internal cabling, c) the EIA connector, or d) the keyboard (LED problem only). If LED's do light OK, try typing characters on the keyboard (KSR only). Are the characters printed? Switch offline. Enter configure mode and program an ABM message and code 71. Switch online. Is the ABM message printed? If so, are they the correct characters? If so, the Model 820 is probably OK and the configuration setup or system protocol is incorrect rather than there being a hardware problem. If not, the problem is in the data flow between the SIO device and the communications connector. Check the cabling connections and the EIA connector. Replace if necessary. Otherwise, replace the main PWB.

NOTE

If the Model 820 KSR or RO seems to be in good condition and the configuration is consistent with the system requirements, and system protocol seems to match the Model 820 Terminal's capabilities, this problem may lie in the interconnection between the Model 820 KSR or RO and the host system. See Section 5.6 for grounding requirements. If a modem system provides for system communication, have the modems tested if possible. Also, make sure the modem attached to the Model 820 conforms to the grounding requirements in Section 5.6. Check all cabling for secure connections.

- 4) Probable areas of trouble: main PWB, configuration, cabling/connections, grounding.

5.6 GROUNDING REQUIREMENTS

The Model 820 must be grounded properly! The Model 820 KSR and RO terminals are equipped with a grounded power cord which is meant to be used as is. This ground line connects the Model 820 KSR or RO chassis (or safety) ground signals to the external ground reference. If an extension cord is to be used with the Model 820 it must be of the three-wire (grounded) type.

5.6.1 CHASSIS GROUND. The power cord ground line is immediately attached to the ground plane network of the Model 820 as it enters the machine. This ground plane network lies beneath the main PWB with straps connecting it to the mechanism and the keyboard assembly. Jumpers connect the main mechanism assembly to the ribbon motor assembly and the communications connector bulkhead. This ground plane network provides for suppression of radio frequency emanations from the Model 820, for noise immunity, for static discharge resistance, and for the distribution of the chassis ground signal to all points in the Model 820 Terminal.

NOTE

If the Model 820 is equipped with a paper basket, the basket should be securely grounded to the case with the supplied ground jumper.

The ground plane beneath the terminal electronics PWB is attached to that PWB via three screws. The first is in the rear right-hand area of the PWB, near E27, and connects chassis ground to J3 and J13, and then through the EIA internal cable to pin 1 of the EIA connector at the rear of the Model 820. The second is near the printhead cable connector and connects the ground plane to the chassis ground network in the power supply as well as grounding (via jumpers) the driver heat sinks. The third and largest screw connects the ground plane directly to the power supply section of the terminal electronics PWB. It is located between the power supply secondary capacitors and the transformer. All three screws must be in place and tightened for proper operation.

5.6.2 SIGNAL GROUND. The signal ground return emanates from the power supply area and branches throughout the terminal electronics PWB, primarily via two bus strips. It provides the logic ground, driver ground, and communications signal ground return paths. Signal ground may be either jumpered directly or capacitively coupled to chassis ground, depending on the jumper configuration among E221, E222, and E223. If E221 and E222 are jumpered together, signal and logic grounds are capacitively coupled and are thus isolated. If E223 is connected to E221 or E222 (they are tied together), signal and logic grounds are now directly coupled.

NOTE

The Model 820 KSR and RO terminals are shipped from the factory with all ground jumpers intact and connected. They should remain this way. The Model 820 terminals are jumpered such as to provide isolation between chassis and signal grounds. Except for the cases noted in the next section, this is the ordinary mode of operation and should provide satisfactory service.

5.6.3 SYSTEM REQUIREMENTS. Any system of which a Model 820 KSR or RO data terminal is to be a part must have one *and only one* common connection between the system's signal and logic grounds. More than one common point between these two signals can set up a condition known as a *ground loop* which can be potentially destructive to the system as well as interfering with its proper operation.

5.6.3.1 Hard-Wired (Console) Applications. If the Model 820 is to be used in any sort of hard-wired applications, such as the console unit of a computer system, or the hard-copy output device for a CRT/host computer network, care must be taken that all of the devices in hard-wired connection with the Model 820 unit are properly grounded. Hard-wired in this context refers to direct wiring between machines without the use of telephone lines.

Each machine of the system should be properly grounded (via a three-wire power cord and a three-wire extension cord, if necessary) and there should exist only one point in the entire system where signal and chassis grounds should meet. Normally this will not be in the Model 820 KSR or RO; however, the jumper network mentioned in the previous section can arrange for this connection. Pin 1 of the EIA connector should be cabled to the host machine's chassis ground pin, usually Pin 1 on its connector, also. Pin 7 (signal ground) should be cabled to the corresponding point on the host system in a similar manner. All cables in the system should be secure and sturdy. Any other units in the system should also have the signal ground and chassis ground returns cabled to them.

5.6.3.2 Data Set Applications. Most data sets are equipped with a three-wire power cable which is *meant to be used*. Any extension cords used in conjunction with the data set should also be of the three-wire variety.

If the Model 820 KSR or RO is to be used with a data set, generally the system consists only of the Model 820 terminal, the data set, and the connecting cable. The telephone lines and the host system are not critical in grounding requirements, i.e., they will not generally affect the operation of the Model 820 system. Most data sets are installed with signal and chassis grounds strapped together, so this can provide the one and only one necessary common point.

Care should be taken to see that the cable between the Model 820 and the data set is properly secured and unworn. Pin 7 of the Model 820 should be connected to Pin 7 of the data set; Pin 1 to Pin 1 is also required.

5.7 ASSEMBLIES REMOVAL AND REPLACEMENT

The following subsections provide removal and replacement procedures for replaceable parts. Refer to Section VI for Texas Instruments' part numbers for assemblies and components.

CAUTION

Do not attempt to remove the connectors named in the following procedures by grasping the cables since the connector bodies can become detached from the plastic housing. If the connectors do not disconnect easily, use needlenose pliers to grasp the connector bodies, not the cables.

5.7.1 FULL OPENING OF TERMINAL COVER. Remove the terminal cover as follows:

- a. Unplug the power cord from the power receptacle at the rear of the terminal.
- b. Open the terminal cover by grasping the right and left front corners and gently lifting until the cover will raise no further. A plastic stay at the inside right rear holds the cover open at approximately 45 degrees from horizontal.
- c. While holding the terminal cover with one hand, grasp the top of the plastic stay with the other hand and move the stay to the right.
- d. Move the top of the plastic stay to the right until it clears the mounting pin.
- e. Holding the stay clear of the pin, the terminal cover can now be swung back until it rests on the desk or table-top in a fully opened position.

Reposition the terminal cover as follows:

- a. Holding the terminal cover with your left hand and the plastic stay attached to the inside right rear of the cover with your right hand, return the cover to an approximate 45 degree position.
- b. Supporting the terminal cover with the plastic stay, align the mounting pin with the stay and engage the plastic stay into the mounting pin.
- c. Close the terminal cover by gently pushing the cover down until the closures snap shut.
- d. Plug the power cord into the power receptacle at the rear of the Model 820 KSR or RO.

Table 5-1. Option PROM/ROM Part Numbers and Locations

Option	TI Part Number	Logic PWB (999694-0001) Device	Socket
DFC Option	2207626-0001	ROM	XU12
User-Defined Configuration or Protected ABM Option	2207628-0001 2207628-0002	PROM PROM	XU24 XU45 (Spare)
Alternate Character Sets	See Table C2 (Appendix C)	PROM	XU23

Table 5-2. Strappable Option On Logic PWB (999947)

Option	Jumper Location
To connect signal ground to chassis ground	E222 to E223
To isolate signal ground from chassis ground (STANDARD)	E221 to E222

5.7.2 REMOVAL AND REPLACEMENT OF THE KEYBOARD PLENUM. Remove the keyboard plenum as follows:

- a. Unplug power cord.
- b. Lift open the terminal cover.
- c. Remove the keyboard bezel by grasping the extreme right and left edges and lifting up.
- d. Manually move the printhead to the right approximately 4 inches to the right of the center of the platen.
- e. Using a standard slot screwdriver, disengage the four retainer clips at the front of the keyboard plenum.
- f. Grasping the right and left front edges of the keyboard plenum, raise the front of the plenum approximately 10 degrees to clear the clip latches.
- g. While supporting the plenum at approximately 10 degrees, disengage the three rear latches beginning with right rear latch.
- h. Lift the plenum clear of the terminal with slight forward motion and set it aside.

Replace the keyboard plenum as follows:

- a. Verify that the printhead is positioned approximately 4 inches to the right of the center of the platen.
- b. Verify that the cable from the mechanism to the PWB is routed correctly and secured properly.
- c. Grasp the edges of the plenum and insert the rear of the plenum between the printhead and cables, ensuring that the plenum fits over the rear fan plenum housing.
- d. Lift the front of the fan plenum approximately 10 degrees and insert the three rear tabs into their respective slots inside the terminal.
- e. Gently push the front of the fan plenum down until it rests on the four front retaining tabs.
- f. Using a standard slot screwdriver, engage the retaining tabs into their respective latches.
- g. Replace the keyboard bezel and close the terminal cover.

5.7.3 REMOVAL AND REPLACEMENT OF THE FAN ASSEMBLY. Remove the fan assembly as follows:

- a. Unplug power cord.

- b. Remove the terminal cover as described in subsection 5.7.1.
- c. Remove the keyboard plenum as described in subsection 5.7.2
- d. Using a standard slot screwdriver, remove the single retaining screw located on top of the fan plenum.
- e. Move the rear of the fan plenum toward the front of the terminal to remove it from under the hinge nut plate. Disengage the feet and lift the plenum up and to the left to remove it from the base.

NOTE

Observe the routing of the fan cable so you can reinstall it the same way.

- f. Disconnect the fan cable (connector P203) at J203 on the PWB and remove the cable from the snap-in type routing guides.
- g. Using a standard slot screwdriver, remove the two mounting screws and lift out the fan assembly.
- h. Slip the fan motor out of its bracket.

Replace the fan assembly as follows:

- a. Install the fan motor into the fan bracket.
- b. Mount the fan bracket with the two mounting screws while tightly grasping the bracket around the fan motor with needlenose pliers. Make sure that the fan blade can rotate freely before securing the two mounting screws.
- c. Reroute the fan assembly cable on the logic PWB as it was originally routed.
- d. Reconnect connector P203 to the PWB.
- e. Replace the fan plenum and the fan plenum retaining screw (ensuring that the two bottom plenum feet are engaged with the base slots and secured with the hinge nut plate).
- f. Replace the keyboard plenum as described in subsection 5.7.2.
- g. Apply power and verify operation.
- h. Replace the terminal cover as described in subsection 5.7.1.

5.7.4 REMOVAL AND REPLACEMENT OF THE KEYBOARD ASSEMBLY (Keyboard PWB)

- a. Unplug power cord.
- b. Lift the terminal cover.
- c. Remove the keyboard bezel by grasping the extreme right and left edges and lifting up the bezel.
- d. Remove the keyboard plenum as described in subsection 5.2.
- e. Remove the 33 mm (1¼ inch) wide sheet metal ground strap attached to the front left corner of the keyboard PWB by pulling it down and away from the plastic connector.

- f. Loosen the four keyboard PWB keepers along the rear edge of the PWB, using both hands to press in at the base of the keepers while lifting the keyboard slightly.
- g. Lift the tach motor cable, paper drive motor cable, and ribbon drive motor out of their cable retainers on the right side of the case.
- h. Remove the 25-conductor ribbon cable from its connector on the Keyboard PWB.
- i. Snap the keyboard keepers up and away from the keyboard.
- j. Lift the keyboard assembly up from the rear and remove the Keyboard PWB out of its plastic mounting assembly.

Replace the keyboard assembly as follows:

- a. Reconnect the 25-conductor ribbon cable to the Keyboard PWB.
- b. Snap the four keyboard assembly keepers back in place (if removed).
- c. Replace the tach motor cable, paper drive motor cable, and ribbon drive motor cable back into their holders on the right side of the case.
- d. Reconnect the ground strap to the front left corner of the Keyboard PWB.
- e. Replace the plenum as described in subsection 5.7.2.
- f. Replace the keyboard bezel and close the terminal cover.
- g. Replace the power cord and apply power to verify operation.

5.7.5 REMOVAL AND REPLACEMENT OF THE LOGIC PWB (Main Electronic PWB). Remove the Logic PWB as follows:

- a. Unplug power cord.
- b. Remove the keyboard assembly as described in subsections 5.7.4 (steps a. through g.).
- c. Lift the keyboard assembly from the terminal.
- d. Remove the two ac power connectors located in the lower left corner of the Logic PWB at E281 and E271 and disconnect the fan cable from J203. Disconnect the connectors attached to J101, J104, J105, J106, J6, and J8.
- e. Disconnect I/O interface connector P3 and the ground leads from the aluminum ground shield.
- f. Unscrew the three mounting screws.
- g. Lift the Logic PWB from the terminal.

NOTE

When replacing the Logic PWB, refer to Table 5-2 for location of the option PROM's and other components which must be transferred to the replacement PWB assembly. Table 5-3 lists strappable options.

Replace the Logic PWB as follows:

- a. Place the Logic PWB in the bottom of the terminal case.
- b. Reinsert the three mounting screws.
- c. Attach the ac power connectors at E281 and E271 and reconnect the I/O interface connector P3, fan connector P203, and ground leads to the aluminum ground shield. Reattach the cable connectors to J101, J104, J105, J106, J6, and J8.
- d. Reinstall the keyboard assembly by inserting the keyboard keeper posts in the slots provided on the Logic PWB.
- e. Complete replacement of the keyboard assembly as described in subsection 5.7.4.

5.7.6 REMOVAL AND REPLACEMENT OF LOGIC PWB BATTERY. Remove the Logic PWB battery as follows:

- a. Unplug the power cord.
- b. Remove the keyboard assembly as described in subsection 5.7.4 (steps a. through g.).
- c. Disconnect the battery cable at J9 located in the upper right corner of the Logic PWB.
- d. Carefully disengage the battery from the RTV adhesive with a knife.

Replace the Logic PWB battery as follows:

- a. Install a new battery (TI part number 999880-0001), using a cable strap or RTV adhesive, and reconnect the connector at J9. Figure 5-3 illustrates the PWB battery details.
- b. Reinstall the keyboard assembly as described in subsection 5.7.4.

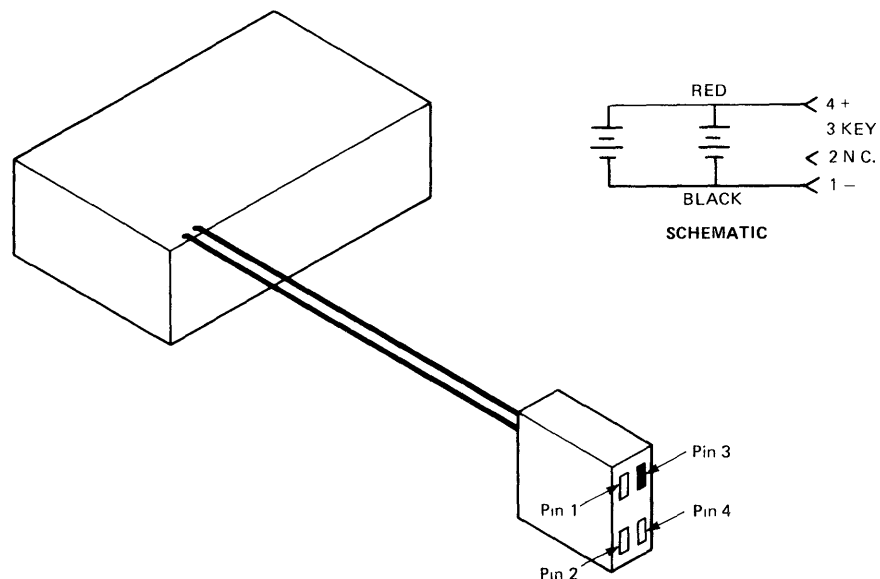

Figure 5-3. Logic PWB Battery Details

5.7.7 REMOVAL AND REPLACEMENT OF PWB FUSE (250V, 3A).

- a. Remove the keyboard assembly as described in subsection 5.7.4 (steps a. through g.)
- b. Replace the fuse (TI part number 416434-0303, LCT 312003) located in the front left corner of the PWB at F250.
- c. Reinstall the keyboard assembly as described in subsection 5.4.

5.7.8 REMOVAL AND REPLACEMENT OF PAPER DRIVE MOTOR. Remove the paper drive motor as follows:

- a. Unplug the power cord.
- b. Remove the terminal cover as described in subsection 5.7.1.
- c. Open the paper drive tractor flaps and remove any paper from the terminal.
- d. Remove the keyboard plenum as described in subsection 5.7.2.
- e. Lift both ribbon spools off their spindles and carefully remove the ribbon from the ribbon guides. Wind the excess ribbon onto either spool and set the ribbon spools aside.
- f. Using a standard slot screwdriver, remove single screw holding the ribbon guide on the right side of the printer subassembly as shown in Figure 5-1. Lay the guide aside. Remove all cable ties from the paper drive motor cable-to-cable bundle (observe location of the cable ties for subsequent replacement).
- g. Using a small wrench or hex driver, loosen the two nuts that hold the paper drive motor to the printer subassembly frame. The motor is attached via studs in the motor case.
- h. Grasp the motor with your right hand while removing the nuts and washers with your left; take care to avoid dropping the parts into the terminal base. Set the nuts and washers aside.
- i. Pull the motor out of the pinion hole and gently lift the motor cable from around the carriage motor (located below the paper drive motor), the cable clip, and the cable holders of the keyboard keepers.
- j. Set the motor on a bench or table top and remove connectors P106 and P104.

Replace the paper drive motor as follows;

- a. Insert the paper drive motor shaft into the hole provided in the printer mechanism frame and seat the motor flange flush with the mechanism side plate. Apply silicone grease (TI Part Number 0232334-6050) between the rivet on the end of the gear and the motor flange.
- b. Push in on the motor and the plastic tractor drive and rotate the motor slightly back and forth until the motor flange and the tractor drive fit flush against the frame.
- c. Align the mounting holes.
- d. Insert the top front screw through the gear bearing housing and frame until the screw engages the motor flange. Start the screw with a screwdriver.

- e. Insert the rear bottom screw through the gear bearing housing and frame and align it in the motor flange. Start the screw by hand.
- f. Tighten both screws.
- g. Route the cable around and under the rear of the carriage motor (located below the paper drive motor) and along the right side of the carriage motor. Insert the cable into the cable restraint and close the restraint.
- h. Place the cable into the two keyboard keepers on the right side. Replace the cable ties removed in step f. of the removal procedure.
- i. Connect P104 and P106 to J104 and J106 on the Logic PWB. Ensure that the connectors are seated all the way down or erratic terminal operation may result.
- j. Replace the right ribbon guide, ensuring that the paper drive motor cable is safely captured between the guide and the side plate.
- k. Replace the ribbon; replace the keyboard plenum as instructed in subsection 5.7.2; and replace the terminal cover as described in subsection 5.7.1.

5.7.9 REMOVAL AND REPLACEMENT OF THE TRACTOR ASSEMBLY. Remove the tractor assembly as follows:

- a. Remove the terminal cover as described in subsection 5.7.1.
- b. Remove the inside **E**-ring from the *round* tractor support rod by applying pressure between the rod and the ring with a screwdriver. Once the ring begins to detach, hold it with your free hand to prevent it from flying off.
- c. Remove the outer snap ring by hand.
- d. Loosen the locking device on the tractors and slide the round rod to the left and out of the mechanism.
- e. Use a standard slot screwdriver to remove the left bearing which supports the tractor *square* drive shaft. Carefully avoid dropping washers and nuts into the terminal base and do not lose the hub and spring located on that end of the bar.
- f. Remove the tractor assembly from the mechanism. (If the tractor drive gear remains on the end of the bar, slide it off and set it aside).
- g. Slide the tractors off the bar; take care not to bend the bar.

Replace the tractor assembly as follows:

- a. Slide the tractors onto the square drive bar. Verify that the locking device for the left tractor is on the left and the locking drive for the right tractor is on the right and that the alignment mark on both tractors' drive sprockets align with same corner of the square drive shaft.
- b. With the tractor doors facing you, place the drive gear (gear fitted tightly on the shaft) on the right end of the shaft with the semicircle portion of the gear adjacent to each flat surface of the shaft.

- c. Insert the gear and shaft into the bearing on the right side plate.
- d. Replace the hub with spring on the left end of the drive shaft with the semicircles of the hub adjacent to each drive shaft surface. Slip the bearing onto the hub and fasten the left side plate.
- e. Slide the round rod (non-grooved end first) from left to right through the left side plate, through the tractors, and through the right side plate.
- f. Using needlenose pliers, replace the E-ring on the round rod, ensuring it is located inside the left side plate.
- g. Replace the outer snap ring on the round rod outside the left side plate.
- h. Position the paper tractors as required and reload printing paper.

5.7.10 REMOVAL AND REPLACEMENT OF THE PRINTHEAD. Remove the printhead as follows:

- a. Disconnect the power cord at the power receptacle located at the rear of the Model 820 KSR or RO.
- b. Lift the terminal cover.
- c. Remove the keyboard plenum as described in subsection 5.7.2.
- d. Remove and save the plastic cable retainer clip at the pointer where the printhead cable is folded beneath the printhead.
- e. Using a small wrench, remove the two long hex nuts located behind the printhead and facing the ribbon guides.
- f. Grasp the printhead and pull it towards the front of the terminal until the two mounting bolts clear the mounting frame.
- g. Disconnect the printhead ribbon cable connector (J20) from the connector at the bottom of the printhead.

Replace the printhead as follows:

CAUTION

When handling the new printhead, take care not to damage the springs after removing the foam shipping material. Grasp the printhead only by the mounting plate or the plastic needle housing. DO NOT handle the printhead by the springs around the circumference of the printhead.

- a. Connect the printhead ribbon cable connector (J20) to the connector at the bottom of the printhead.
- b. Position the printhead so that the mounting screws align with the mounting holes in the support frame and slide the printhead toward the platen as far as it will go.
- c. Start the two long nuts on the mounting screws and hand tighten.
- d. With a small wrench or pliers tighten the long nuts 1/6 turn past hand tightened.

- e. Replace the plastic cable clip, starting the clip at the end with the notched corner.
- f. Replace the plenum as described in subsection 5.7.2 and reconnect the power cord to the rear of the terminal.
- g. If the printhead smudges the paper during printing and the problem cannot be corrected with the form thickness adjustment, it may be necessary to adjust the ribbon guide at the nose of the printhead as described in subsection 5.7.11.
- h. Close the terminal cover.

5.7.11 PRINTHEAD RIBBON GUIDE ADJUSTMENT.

- a. Lift the terminal cover and rotate the printhead adjustment lever all the way towards the keyboard.
- b. Remove the ribbon as described in step 5.7.8.e above.
- c. Loosen the two screws on either side of the nose of the printhead and slide the ribbon guide away from the platen, exposing the printhead nose through the ribbon guide window.
- d. Place a shim (file card, credit card, TI Badge, etc.) between the platen and the printhead nose.
- e. Using the adjustments lever, push the printhead nose against the shim until it is held firmly against the platen.
- f. Slide the ribbon guide toward the platen holding it flush against the shim and tighten the screws. Using the adjust lever remove the shim.
- g. Replace the printing ribbon and set the printhead adjust lever for proper printing.

5.7.12 REMOVAL AND REPLACEMENT OF THE RIBBON DRIVE SUBASSEMBLY. Remove the ribbon drive subassembly as follows:

- a. Unplug the power cord.
- b. Remove the terminal cover as described in subsection 5.7.1.
- c. Remove the printing ribbon spools from the ribbon spindles and guides and set aside.
- d. Remove the three screws that attach the ribbon drive subassembly to the printer mechanism frame.
- e. Tilt the subassembly backward to rest in the rear cavity of the terminal base.
- f. Remove the two space lugs from the ribbon reverse switch, noting their orientation for reconnection to the replacement unit.
- g. Cut the cable tie that secures the motor cable to the rear bar of the printer mechanism frame and the cable ties attaching it to the rest of cable, noting position of cable ties.
- h. Disconnect cable connector P101 from the Logic PWB (the main PWB) and carefully lift the cable out of the keyboard keepers, the cable restraint and from around the carriage motor.

Replace the ribbon drive subassembly as follows:

- a. Lay the replacement assembly in the rear cavity of the terminal base.
- b. Attach the two spade lugs to the ribbon reverse microswitch of the ribbon drive subassembly. Verify that the connections are oriented the same as the unit that was removed or the ribbon will not reverse automatically.
- c. Attach a cable tie to hold the motor cable to the rear frame bar of the print mechanism.
- d. Hold the ribbon drive subassembly in place and install the three screws that secure the subassembly to the rear of the print mechanism framework.
- e. Route the ribbon drive motor cable around and under the carriage motor and through the cable restraint. Using cable ties replace those removed in step g of the removal instructions.
- f. Connect P101 at J101 on the Logic PWB, ensuring that the connector is snugly joined.
- g. Place the cables in the keyboard keeper cable retainer.
- h. Replace the printing ribbon. It may be necessary to readjust the subassembly (by loosening the three mounting screws and moving the assembly to front or rear and retightening the screws) so that the ribbon passes through the center of the slots in the shift arm.
- i. Replace the terminal cover as instructed in subsection 5.7.1.

5.7.13 REMOVAL OF THE CARRIAGE MOTOR AND MECHANISM (Or Wire Rope Or Mechanism). To replace the wire rope, do steps "a", "b", "f", and "j" to remove, and steps "f" through "k" and "o" and "q" under replacement to reinstall the rope.

- a. Unplug the power cord.
- b. Remove the terminal cover and plenums as described in subsections 5.7.1, 5.7.2 and 5.7.3, respectively.
- c. Disconnect the ground strap on the left side of the mechanism that is attached to the PWB ground plane.
- d. Disconnect the ground lug at the rear of the terminal to the left of the EIA connector.
- e. Disconnect all the connectors at the rear of the Logic PWB, (including the printhead ribbon cable) and lift the cables out of the cable restraint and keyboard keepers. Remove all cable ties, noting their positions.
- f. Push the idler pully support to the right until the slot on the bottom of the support catches on the right sideplate of the print mechanism frame.
- g. Insert a slotted screwdriver at an angle next to the upper printhead carriage rod to remove the front two mounting screws.
- h. Remove the two rear mounting screws.
- i. Lift the entire printer mechanism subassembly up and out of the terminal. **DO NOT LIFT THE MECHANISM BY THE SQUARE TRACTOR DRIVE SHAFT.**

- j. Remove the wire rope from the capstan by disengaging the end of the wire rope from either end of the capstan and unwrapping the wire.
- k. Remove the ground strap screw from the front of the motor and remove the ground strap.
- l. Loosen the motor strap retaining screw inside the bottom of the right sideplate.
- m. Press down on the top of the motor strap to disengage the strap from the sideplate.
- n. Remove the carriage motor.
- o. Remove the plastic cradle from the carriage motor by removing the screw that holds the cradle to the motor.
- p. Remove the two wires from the motor terminal, noting their orientation for connecting the replacement unit.

Replace the carriage motor and mechanism as follows:

- a. Connect the motor drive cable spade lugs to the carriage motor terminals as they were connected to the old motor.
- b. Attach the plastic cradle to the motor.
- c. Position the motor against the sideplate.
- d. Hook the motor strap onto the tab in the sideplate and tighten the retaining screw.
- e. Replace the ground strap onto the front of the motor with the screw that previously held it.
- f. Turn the wire rope capstan so that the rear wire rope is at the top.
- g. Insert the ball of the top wire rope end into the slot. The tip of a screwdriver may be required to press the ball for a snug fit.
- h. Holding the wire rope between your left thumb and forefinger, turn the capstan clockwise $6\frac{1}{2}$ turns.
- i. Guide the wire rope into the capstan grooves. When complete, the outer capstan slot should be pointing up.
- j. Wrap the lower end of the wire rope counterclockwise around the capstan starting with the groove adjacent to the last one filled by the upper rope end.
- k. Insert the ball into the capstan slot.
- l. Loop the printhead cable and the motor cables over the tractor drive bar to keep them out of the way during installation of the printer mechanism subassembly.
- m. Replace the printer mechanism into the terminal base so that mounting screw holes are aligned with the mounting holes in the base. **DO NOT LIFT THE MECHANISM BY THE SQUARE TRACTOR DRIVE SHAFT.**
- n. Insert the mounting screws and partially tighten them.

- o. Gently return the idler pulley support to the operating position by lifting the right end while holding the support to the right with your free hand, preventing the pulley from snapping back.
- p. Route and connect all the cables, including the ground lugs to the left of the EIA connector and the ground strap on the left side. Replace all cable ties removed in step e. of the removal procedure.
- q. Replace the plenums and terminal cover as described in subsections 5.7.3, 5.7.2 and 5.7.1, respectively.

SECTION VI ASSEMBLY DRAWINGS AND LISTS OF MATERIALS

FUNCTIONAL INDEX

TI Drawing No.	Major Assemblies	Page No.
n/a	Figure 6-1 Model 820 KSR Illustrated Major Assemblies	6-5
n/a	Figure 6-2 Model 820 RO Illustrated Major Assemblies	6-6
999695	Model 820 KSR 10 CPI Terminal	6-7
999686	Model 820 KSR 10/16 CPI Terminal	6-12
999685	Model 820 KSR 10/16 CPI Package	6-17
999975	Model 820 RO 10 CPI Terminal	6-20
999980	Model 820 RO 10/16 CPI Terminal	6-25
999979	Model 820 RO 10/16 CPI Package	6-29
999690	Model 820 Basic Terminal	6-33
Major Sub-Assemblies		
999691	KSR Keyboard, Full ASCII or APL	6-48
999859	KSR Keyboard, Katakana	6-54
2206573	Mechanism	6-57
999972	RO Control Panel	6-67
999974	Terminal Electronics Board w/Ground Plane	6-69
999947	Terminal Electronics PWB	6-72
Sub-Assemblies		
999913	Carriage Assembly, Printhead	6-114
994238	Carriage Drive Assembly	6-116
999819	Fan Assembly	6-119
999780	Gear Assembly, Paper Advance	6-121
999872	Ground Plane Assembly	6-123
999829	Motor Assembly, Paper Drive	6-125
999738	Motor Assembly, Ribbon Drive	6-127
999732	Printhead Assembly, 30 Volt	6-129
999687	Ribbon Drive Assembly	6-132
999918	Terminal Cover Assembly	6-136
999925	Test Plug	6-139
Cables		
993205	Cable Assembly, 202/212	6-141
999736	Cable Assembly, Carriage Drive	6-143
993210	Cable Assembly, Data Terminal	6-145
996289	Cable Assembly, Domestic Power	6-147
993211	Cable Assembly, EIA Extension	6-152
999742	Cable Assembly, EIA (Internal)	6-154
996290	Cable Assembly, European Power	6-156
999790	Cable Assembly, Keyboard	6-160
999873	Cable Assembly, Mechanism Ground	6-162
999835	Cable Assembly, Power Distribution	6-164
999791	Cable Assembly, Printhead	6-166
999735	Cable Assembly, Ribbon Reverse/Paper Out	6-168
2207634	Cable Assembly, Synch/Asynch EIA Data Set	6-170

OPTIONS

994403	Cable Assembly, Current Loop (Ext)	6-172
2206536	Cable Assembly, Current Loop Power	6-174
2206535	Cable Assembly, I/O Current Loop	6-176
2207630	Kit, Configuration/Protected ABM PROM's	6-178
999734	Kit, 20 mA Current Loop Interface	6-180
999836	Kit, Device/Forms Control	6-182
2206548	Panel Assembly, EIA/Current Loop	6-184
2206532	PWB Assembly, Current Loop	6-186
2206534	Shorting Plug, Current Loop	6-189

NUMERICAL LISTING OF ASSEMBLY DRAWINGS AND LISTS OF MATERIALS

This listing is provided for cross-reference purposes.

TI Drawing No.	Major Assemblies	Page No.
993205	Cable Assembly, 202/212	6-141
993210	Cable Assembly, Data Terminal	6-145
993211	Cable Assembly, EIA Extension	6-152
994238	Carriage Drive Assembly	6-116
994403	Cable Assembly, Current Loop (Ext)	6-172
999685	Model 820 KSR 10/16 CPI Package	6-29
999686	Model 820 KSR 10/16 CPI Terminal	6-25
999687	Ribbon Drive Assembly	6-132
999690	Model 820 Basic Terminal	6-33
999691	KSR Keyboard, Full ASCII or APL	6-48
999695	Model 820 RO 10 CPI Terminal	6-7
999710	ASCII Keyboard (KSR)	7-3
999732	Printhead Assembly 30 Volt	6-129
999734	Kit, 20 mA Current Loop Interface	6-180
999735	Cable Assembly, Ribbon Reverse/Paper Out	6-168
999736	Cable Assembly, Carriage Drive	6-143
999738	Motor Assembly, Ribbon Drive	6-127
999742	Cable Assembly, EIA (Internal)	6-154
999780	Gear Assembly, Paper Advance	6-121
999790	Cable Assembly, Keyboard	6-160
999791	Cable Assembly, Printhead	6-166
999819	Fan Assembly	6-119
999835	Cable Assembly, Power Distribution	6-164
999836	Kit, Device/Forms Control	6-182
999859	KSR Keyboard, Katakana	6-54
999872	Ground Plane Assembly	6-123
999873	Cable Assembly, Mechanism Ground	6-162
999913	Carriage Assembly, Printhead	6-114
999918	Terminal Cover Assembly	6-136
999925	Test Plug	6-139
999945	Terminal Electronics	7-5
999947	Terminal Electronics PWB	6-72
999951	Operator's Panel (RO)	7-19
999972	RO Control Panel	6-67
999974	Terminal Electronics Board w/Ground Plane	6-69
999975	Model 820 RO 10 CPI Terminal	6-20
999979	Model 820 RO 10/16 CPI Package	6-29
999980	Model 820 RO 10/16 CPI Terminal	6-25
2206530	Current-Loop Electronics	7-21
2206532	PWB Assembly, Current Loop	6-186
2206534	Shorting Plug, Current Loop	6-189
2206535	Cable Assembly, I/O Current Loop	6-176

TI Drawing No.	Assemblies	Page No.
2206536	Cable Assembly, Current Loop Power	6-174
2206548	Panel Assembly EIA/Current Loop	6-184
2206573	Mechanism	6-57
2207630	Kit, Configuration/Protected ABM PROM's	6-178
2207634	Cable Assembly, Synch/Asynch EIA Data Set	6-170

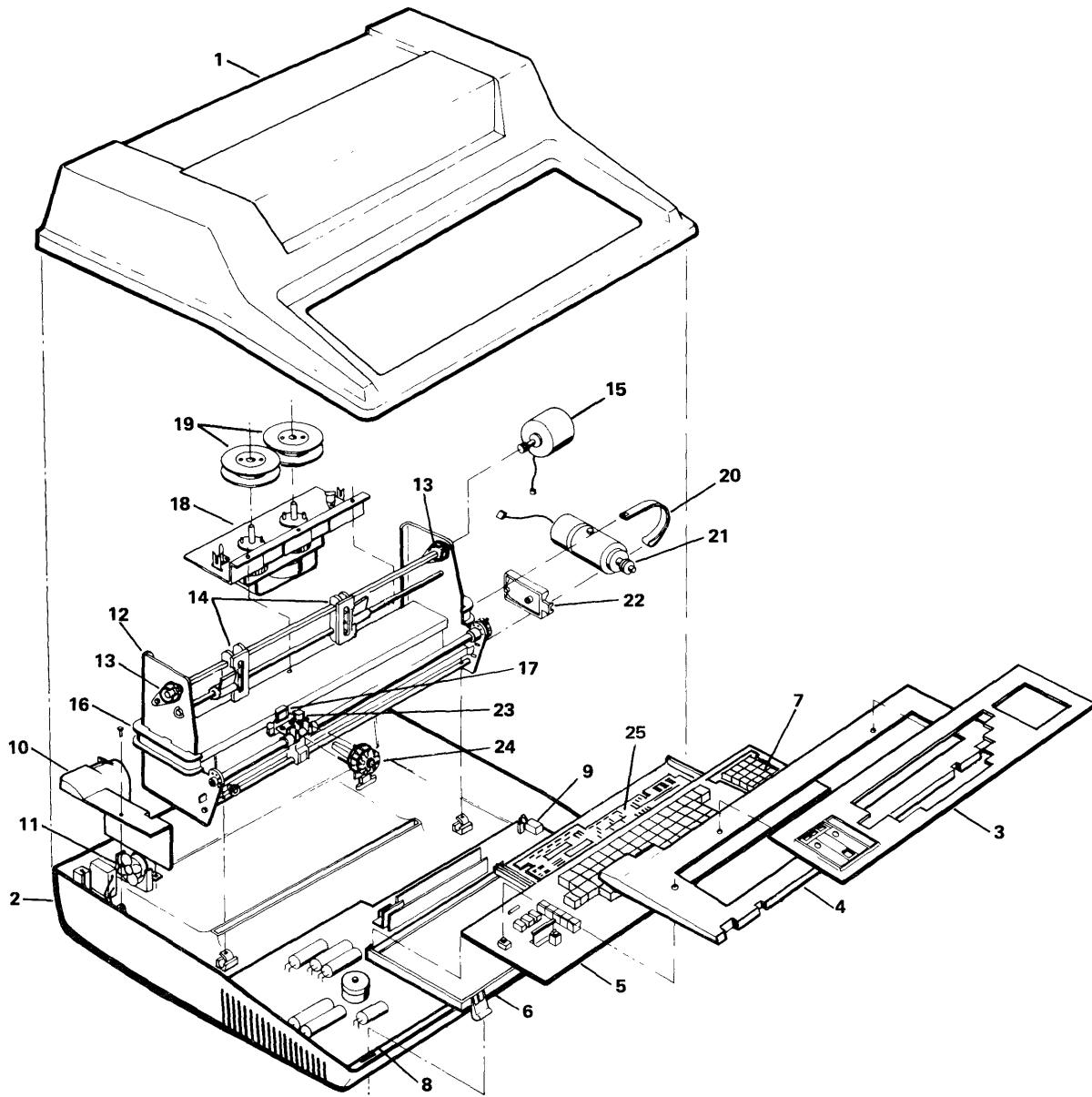

- 1. Terminal Cover
- 2. Terminal Base
- 3. Keyboard Bezel
- 4. Plenum,PWB
- 5. Keyboard,PWB
- 6. Card Frame
- 7. Numeric Keypad
- 8. Terminal Electronics

- 9. Kit,Battery,Package
- 10. Fan Plenum
- 11. Fan Assembly
- 12. Printer Mechanism Assembly
- 13. Paper Advance Bearing
- 14. Tractor,Paper,Precision
- 15. Motor Assembly,Paper Drive
- 16. Ribbon Guide

- 17. Nose Guide,Printhead
- 18. Ribbon Drive
- 19. Ribbon Spools
- 20. Strap,Motor
- 21. Carriage Drive Motor Assembly
- 22. Cradle Motor
- 23. Carriage Assembly,Printhead
- 24. Printhead Assembly,30V
- 25. Printed Wiring Board (PWB)

Figure 6-1. MODEL 820 KSR ILLUSTRATED MAJOR ASSEMBLIES

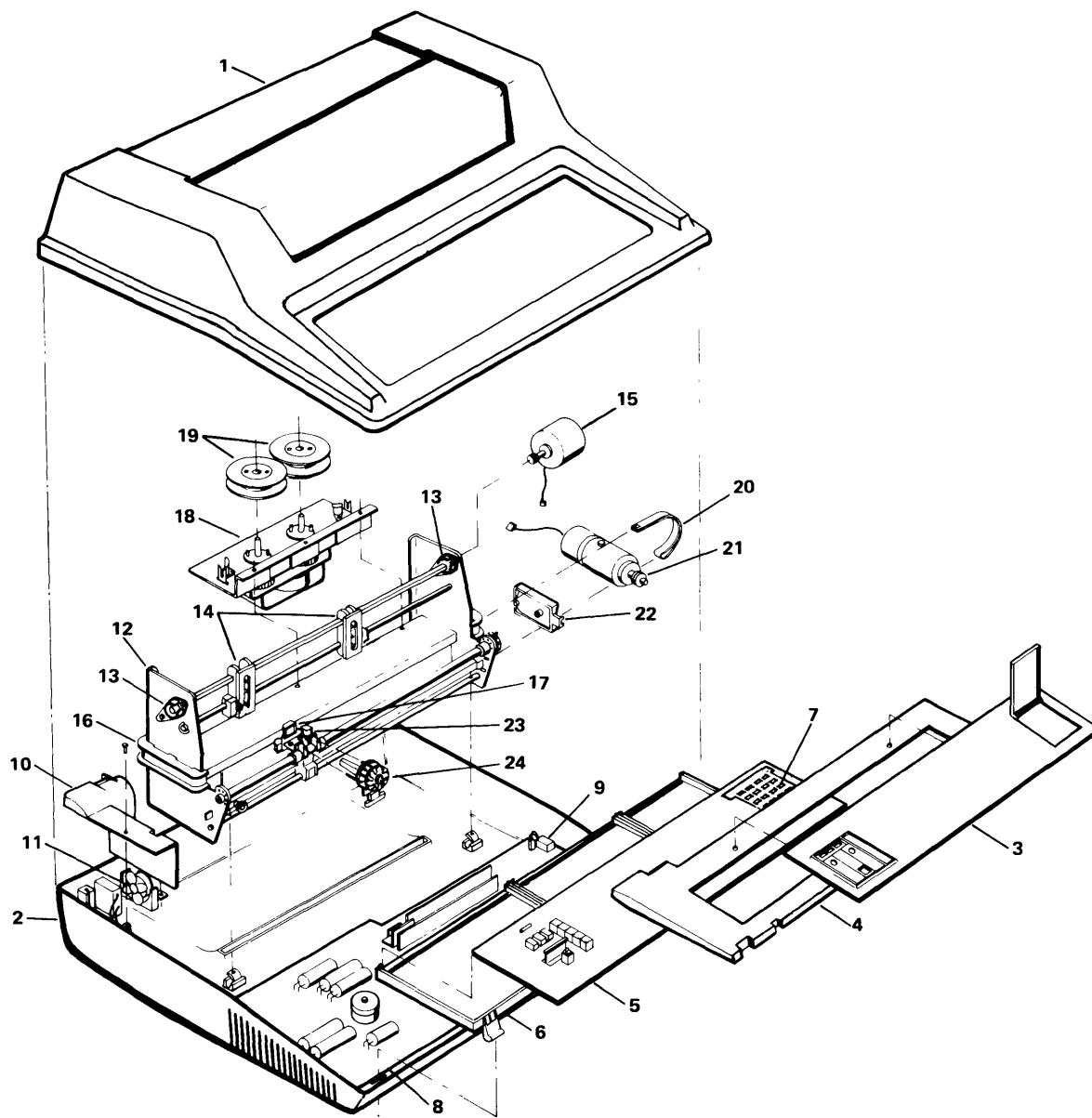

- 1. Terminal Cover
- 2. Terminal Base
- 3. Keyboard Bezel
- 4. Plenum,PWB
- 5. Keyboard,PWB
- 6. Card Frame
- 7. Operator's Keypad
- 8. Terminal Electronics

- 9. Kit,Battery,Package
- 10. Fan Plenum
- 11. Fan Assembly
- 12. Printer Mechanism Assembly
- 13. Paper Advance Bearing
- 14. Tractor,Paper,Precision
- 15. Motor Assembly,Paper Drive
- 16. Ribbon Guide

- 17. Nose Guide,Printhead
- 18. Ribbon Drive
- 19. Ribbon Spools
- 20. Strap,Motor
- 21. Carriage Drive Motor Assembly
- 22. Cradle Motor
- 23. Carriage Assembly,Printhead
- 24. Printhead Assembly,30V

Figure 6-2. MODEL 820 RO ILLUSTRATED MAJOR ASSEMBLIES.

LIST OF MATERIALS

DATE 07-12-79
P/N 0999695

820 KSR Terminal, 10 CPI

0101
REV L

PRINT ITEM NUMBER	QUANTITY PER ASSEMBLY	PART NUMBER	DESCRIPTION
0001	00001.000	0999690-0101	820 TERMINAL,BASIC-115V,10CPI
0004	00001.000	0999746-0001	PLENUM,PWB
0005	00001.000	0999747-0001	INSULATOR, SOUND AIR PLENUM
0006	00001.000	0999748-0001	COVER,TEST
0008	00001.000	0996704-0001	RIBBON,BLK MATRIX-SINGLE 60 YARD
0009	00001.000	0999854-9701	MANUAL, USER GUIDE
0010	00000.020	0996472-0001	PAPER,CPO-1 PART PREMIUM
0012	00001.000	0999456-9701	MANUAL,INFORMATION REQUEST FORM
0013	REF	0999760-9901	SHIPPING CONTAINER INDEX, 820 TERM
0014	00001.000	0999457-9701	MANUAL,FIELD SERVICE FLYER
0016	REF	0999858-9701	INSTRUCTIONS, PACKING
0017	00001.000	0999860-9701	MANUAL, RIBBON & PAPER RECOMMENDATIONS
0018	00001.000	0999713-0001	WINDOW, TERMINAL
0023	00001.000	0994472-0001	SERVICE KIT,MODEL 810 PRINTER
0025	00001.000	0996289-0001	CORD SET,3-PIN PWR-DOMESTIC BLACK
0025A			ITEM 26 MAY BE USED IN
0025B			PLACE OF ITEM 25
0026	00000.000	0996289-0002	CORD SET,3-PIN PWR-DOMESTIC GRAY W/CLIP
0026A			ITEM 25 MAY BE USED IN
0026B			PLACE OF ITEM 26
0027	REF	0999883-0001	INTERCONNECTION DIAGRAM, 820 KSR
0028	00001.000	0999934-0001	CARD CARRIER ASSY
0029	00000.000	2206541-0101	820 KSR, 115V 10 CPI E/D
0029A			ITEM 29 MAY BE USED IN
0029B			PLACE OF THIS UNIT IN ITS
0029C			ENTIRETY

LIST OF MATERIALS

DATE 07-12-79
P/N 0999695

820 KSR Terminal, 10 CPI

000 0201
REV L

PRINT ITEM NUMBER	QUANTITY PER ASSEMBLY	PART NUMBER	DESCRIPTION
0001	00001.000	J999690-0201	820 TERMINAL,BASIC-220V,10 CPI
0004	00001.000	J999746-0001	PLENUM,PWB
0005	00001.000	J999747-0001	INSULATOR, SOUND AIR PLENUM
0006	00001.000	J999748-0001	COVER,TEST
0008	00001.000	J996704-0001	RIBBON,BLK MATRIX-SINGLE 60 YARD
0009	00001.000	J999854-9701	MANUAL, USER GUIDE
0010	00000.020	J996472-0001	PAPER,CPO-1 PART PREMIUM
0012	00001.000	J999456-9701	MANUAL,INFORMATION REQUEST FORM
0013	REF	J999760-9901	SHIPPING CONTAINER INDEX, 820 TERM
0014	00001.000	J999457-9701	MANUAL,FIELD SERVICE FLYER
0016	REF	J999858-9701	INSTRUCTIONS, PACKING
0017	00001.000	J999860-9701	MANUAL, RIBBON & PAPER RECOMMENDATIONS
0018	00001.000	J999713-0001	WINDOW, TERMINAL
0023	00001.000	J994472-0001	SERVICE KIT,MODEL 810 PRINTER
0025	00001.000	J996290-0001	CURD SET,POWER-WEST EUROPEAN
0027	REF	J999883-0001	INTERCONNECTION DIAGRAM, 820 KSR
0028	00001.000	J999934-0001	CARD CARRIER ASSY
0029	00000.000	2206541-0201	820 KSR, 220V 10 CPI E/D
0029A			ITEM 29 MAY BE USED IN
0029B			PLACE OF THIS UNIT IN ITS
0029C			ENTIRETY

LIST OF MATERIALS

DATE 07-12-79
P/N 0999695

820 KSR Terminal, 10 CPI

000 0401
REV L

PRINT ITEM NUMBER	QUANTITY PER ASSEMBLY	PART NUMBER	DESCRIPTION
0001	00001.000	0999690-0401	820 TERMINAL,BASIC-220V,10 CPI (BPO)
0004	00001.000	0999746-0001	PLENUM,PWB
0005	00001.000	0999747-0001	INSULATOR, SOUND AIR PLENUM
0006	00001.000	0999748-0001	COVER,TEST
0008	00001.000	0996704-0001	RIBBON,BLK MATRIX-SINGLE 60 YARD
0009	00001.000	0999854-9701	MANUAL, USER GUIDE
0010	00000.020	0996472-0001	PAPER,CPO-1 PART PREMIUM
0012	00001.000	0999456-9701	MANUAL,INFORMATION REQUEST FORM
0013	REF	0999760-9901	SHIPPING CONTAINER INDEX, 820 TERM
0014	00001.000	0999457-9701	MANUAL,FIELD SERVICE FLYER
0016	REF	0999858-9701	INSTRUCTIONS, PACKING
0017	00001.000	0999860-9701	MANUAL, RIBBON & PAPER RECOMMENDATIONS
0018	00001.000	0999713-0001	WINDOW, TERMINAL
0023	00001.000	0994472-0001	SERVICE KIT,MODEL 810 PRINTER
0025	00001.000	0996290-0001	CORD SET,POWER-WEST EUROPEAN
0027	REF	0999883-0001	INTERCONNECTION DIAGRAM, 820 KSR
0028	00001.000	0999934-0001	CARD CARRIER ASSY
0029	00000.000	2206541-0401	820 KSR 220V,10 CPI,E/D (BPO)
0029A			ITEM 29 MAY BE USED IN
0029B			PLACE OF THIS UNIT IN ITS
0029C			ENTIRETY

LIST OF MATERIALS

DATE 07-12-79
P/N 0999686

820 KSR Terminal, 10/16 CPI

0101
REV J

PRINT ITEM NUMBER	QUANTITY PER ASSEMBLY	PART NUMBER	DESCRIPTION
0001	00001.000	0999690-0102	820 TERMINAL,BASIC-115V,10/16CPI
0004	00001.000	0999746-0001	PLENUM,PWB
0005	00001.000	0999747-0001	INSULATOR, SOUND AIR PLENUM
0006	00001.000	0999748-0001	COVER,TEST
0008	00001.000	0996704-0001	RIBBON,BLK MATRIX-SINGLE 60 YARD
0009	00001.000	0999854-9701	MANUAL, USER GUIDE
0010	00000.020	0996472-0001	PAPER,CPO-1 PART PREMIUM
0012	00001.000	0999456-9701	MANUAL,INFORMATION REQUEST FORM
0013	REF	0999760-9901	SHIPPING CONTAINER INDEX, 820 TERM
0014	00001.000	0999457-9701	MANUAL,FIELD SERVICE FLYER
0016	REF	0999858-9701	INSTRUCTIONS, PACKING
0017	00001.000	0999860-9701	MANUAL, RIBBON & PAPER RECOMMENDATIONS
0018	00001.000	0999713-0001	WINDOW, TERMINAL
0023	00001.000	0994472-0001	SERVICE KIT,MODEL 810 PRINTER
0025	00001.000	0996289-0001	CORD SET,3-PIN PWR-DOMESTIC BLACK
0025A			ITEM 26 MAY BE USED IN
0025B			PLACE OF ITEM 25
0026	00000.000	0996289-0002	CORD SET,3-PIN PWR-DOMESTIC GRAY W/CLIP
0026A			ITEM 25 MAY BE USED IN
0026B			PLACE OF ITEM 26
0027	REF	0999883-0001	INTERCONNECTION DIAGRAM, 820 KSR
0028	00001.000	0999934-0001	CARD CARRIER ASSY
0029	00000.000	2206542-0101	820 KSR, 115V 10/16 CPI, E/D
0029A			ITEM 29 MAY BE USED IN
0029B			PLACE OF THIS UNIT IN ITS
0029C			ENTIRETY

LIST OF MATERIALS

DATE 07-12-79
P/N 0999686

820 KSR Terminal, 10/16 CPI

0201
REV J

PRINT ITEM NUMBER	QUANTITY PER ASSEMBLY	PART NUMBER	DESCRIPTION
0001	00001.000	0999690-0202	820 TERMINAL,BASIC-220V,10/16 CPI
0004	00001.000	0999746-0001	PLENUM,Pwb
0005	00001.000	0999747-0001	INSULATOR, SOUND AIR PLENUM
0006	00001.000	0999748-0001	COVER,TEST
0008	00001.000	0996704-0001	RIBBON,BLK MATRIX-SINGLE 60 YARD
0009	00001.000	0999854-9701	MANUAL, USER GUIDE
0010	00000.020	0996472-0001	PAPER,CPO-1 PART PREMIUM
0012	00001.000	0999456-9701	MANUAL,INFORMATION REQUEST FORM
0013	REF	0999760-9901	SHIPPING CONTAINER INDEX, 820 TERM
0014	00001.000	0999457-9701	MANUAL,FIELD SERVICE FLYER
0016	REF	0999858-9701	INSTRUCTIONS, PACKING
0017	00001.000	0999860-9701	MANUAL, RIBBON & PAPER RECOMMENDATIONS
0018	00001.000	0999713-0001	WINDOW, TERMINAL
0023	00001.000	0994472-0001	SERVICE KIT,MODEL 810 PRINTER
0026	00001.000	0996290-0001	CORD SET,POWER-WEST EUROPEAN
0027	REF	0999883-0001	INTERCONNECTION DIAGRAM, 820 KSR
0028	00001.000	0999934-0001	CARD CARRIER ASSY
0029	00000.000	2206542-0201	820 KSR, 220V 10/16 CPI, E/D
0029A			ITEM 29 MAY BE USED IN
0029B			PLACE OF THIS UNIT IN ITS
0029C			ENTIRETY

LIST OF MATERIALS

DATE 07-12-79
P/N 0999686

820 KSR Terminal, 10/16 CPI

0401
REV J

PRINT ITEM NUMBER	QUANTITY PER ASSEMBLY	PART NUMBER	DESCRIPTION
0001	00001.000	0999690-0402	820 TERMINAL,BASIC-220V,10/16 CPI (BPO)
0004	00001.000	0999746-0001	PLENUM,PWB
0005	00001.000	0999747-0001	INSULATOR, SOUND AIR PLENUM
0006	00001.000	0999748-0001	COVER,TEST
0008	00001.000	0996704-0001	RIBBON,BLK MATRIX-SINGLE 60 YARD
0009	00001.000	0999854-9701	MANUAL, USER GUIDE
0010	00000.020	0996472-0001	PAPER,CPO-1 PART PREMIUM
0012	00001.000	0999456-9701	MANUAL,INFORMATION REQUEST FORM
0013	REF	0999760-9901	SHIPPING CONTAINER INDEX, 820 TERM
0014	00001.000	0999457-9701	MANUAL,FIELD SERVICE FLYER
0016	REF	0999858-9701	INSTRUCTIONS, PACKING
0017	00001.000	0999860-9701	MANUAL, RIBBON & PAPER RECOMMENDATIONS
0018	00001.000	0999713-0001	WINDOW, TERMINAL
0023	00001.000	0994472-0001	SERVICE KIT,MODEL 810 PRINTER
0026	00001.000	0996290-0001	CORD SET,POWER-WEST EUROPEAN
0027	REF	0999883-0001	INTERCONNECTION DIAGRAM, 820 KSR
0028	00001.000	0999934-0001	CARD CARRIER ASSY
0029	00000.000	2206542-0401	820 KSR 220V 10/16 CPI,E/D (BPO)
0029A			ITEM 29 MAY BE USED IN
0029B			PLACE OF THIS UNIT IN ITS
0029C			ENTIRETY

LIST OF MATERIALS

DATE 06-25-79
P/N 0999685

820 KSR Package, 10/16 CPI

0101
REV C

PRINT ITEM NUMBER	QUANTITY PER ASSEMBLY	PART NUMBER	DESCRIPTION
0001	00001.000	0999690-0102	820 TERMINAL,BASIC-115V,10/16CPI
0004	00001.000	0999746-0001	PLENUM,PMB
0005	00001.000	0999747-0001	INSULATOR, SOUND AIR PLENUM
0006	00001.000	0999748-0001	COVER,TEST
0007	00001.000	0999934-0001	CARD CARRIER ASSY
0008	00001.000	0996704-0001	RIBBON,BLK MATRIX-SINGLE 60 YARD
0009	00001.000	0999854-9701	MANUAL, USER GUIDE
0010	00000.020	0996472-0001	PAPER,CPO-1 PART PREMIUM
0012	00001.000	0999456-9701	MANUAL,INFORMATION REQUEST FORM
0013	0 R E F	0999760-9901	SHIPPING CONTAINER INDEX, 820 TERM
0014	00001.000	0999457-9701	MANUAL,FIELD SERVICE FLYER
0016	REF	0999858-9701	INSTRUCTIONS, PACKING
0017	00001.000	0999860-9701	MANUAL, RIBBON & PAPER RECOMMENDATIONS
0018	00001.000	0999713-0001	WINDOW, TERMINAL
0023	00001.000	0994472-0001	SERVICE KIT,MODEL 810 PRINTER
0024	00001.000	0993205-0001	CABLE ASSY,202/212 DATA SET
0025	00001.000	0996289-0001	CORD SET,3-PIN PWR-DOMESTIC BLACK
0025A			ITEM 26 MAY BE USED IN
0025B			PLACE OF ITEM 25
0026	00000.000	0996289-0002	CORD SET,3-PIN PWR-DOMESTIC GRAY W/CLIP
0026A			ITEM 25 MAY BE USED IN
0026B			PLACE OF ITEM 26
0027	00001.000	0999691-0102	KIT,KYBD ASSY,FULL ASCII W/NUMERIC PAD
0028	00001.000	0999845-0001	KIT,DEVICE/FORMS CONTROL
0029	REF	0999883-0001	INTERCONNECTION DIAGRAM, 820 KSR
0030	00000.000	2206543-0101	820 PACK, 115V 10/16 CPI, E/D
0030A			ITEM 30 MAY BE USED IN
0030B			PLACE OF THIS UNIT IN IT'S
0030C			ENTIRETY

REVISIONS		
REV. NO.	DESCRIPTION	DATE
2	CU 93382 C 12	12/22/72
1 LM-0101 AND -0201 DELETED ITEM 24 WAS DN		
999205-1 BTT I (2) CREATED -0401 LM		

NOTES:
 1 THE WINDOW SHALL BE FREE OF ANY OBVIOUS
 FLAWS AND SCRATCHES WHEN VIEWED FROM
 A DISTANCE OF 3 FEET AND HAVING A NORMAL
 VIEWING ANGLE OF 30° OVERHEAD LIGHTING
 HAVING 75 TO 100 FOOT CANDLES IS REQUIRED
 WITH AN INSPECTION TIME PER WINDOW OF 4
 SECONDS. WINDOW MUST BE PROPERLY
 SAMPLED IN THE COVER WITH THE BACKGROUND
 BEING 152 COLUMNS OF PRINTED BARBERPOLE TEXT.

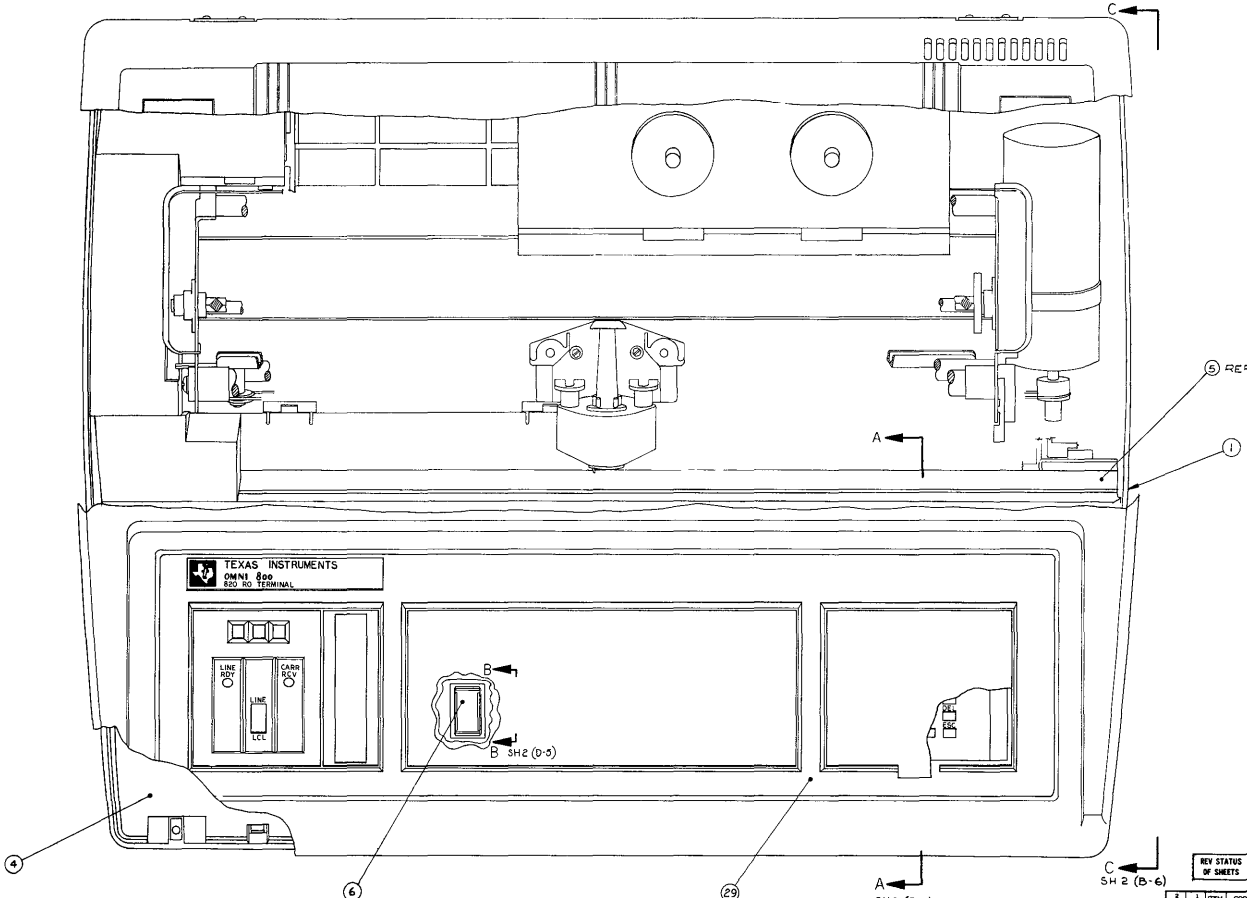

999975-0401	820 RO PRINTER, 10 CPI, 220V 60C
999975-0201	820 RO PRINTER, 10 CPI, 220V
999975-0101	820 RO PRINTER, 10 CPI, 115V
PART NUMBER	DESCRIPTION

REV STATUS	REV	A	X
OF SHEETS	SH	7	2

PARTS LIST			
QTY	ITEM	CODE	PART OR IDENTIFYING NUMBER
			UNLESS OTHERWISE SPECIFIED DIMENSIONS ARE IN INCHES TOLERANCES UNLESS SHOWN OTHERWISE ARE: .0005 IN. .001 IN. .002 IN. .005 IN. .010 IN. .015 IN. .030 IN. .050 IN. .100 IN. .150 IN. .300 IN. .500 IN. 1.000 IN. 1.500 IN. 2.000 IN. 3.000 IN. 4.000 IN. 5.000 IN. 6.000 IN. 8.000 IN. 10.000 IN. 12.000 IN. 15.000 IN. 20.000 IN. 25.000 IN. 30.000 IN. 40.000 IN. 50.000 IN. 60.000 IN. 75.000 IN. 100.000 IN. 125.000 IN. 150.000 IN. 200.000 IN. 250.000 IN. 300.000 IN. 400.000 IN. 500.000 IN. 600.000 IN. 750.000 IN. 1000.000 IN. 1250.000 IN. 1500.000 IN. 2000.000 IN. 2500.000 IN. 3000.000 IN. 4000.000 IN. 5000.000 IN. 6000.000 IN. 7500.000 IN. 10000.000 IN. 12500.000 IN. 15000.000 IN. 20000.000 IN. 25000.000 IN. 30000.000 IN. 40000.000 IN. 50000.000 IN. 60000.000 IN. 75000.000 IN. 100000.000 IN. 125000.000 IN. 150000.000 IN. 200000.000 IN. 250000.000 IN. 300000.000 IN. 400000.000 IN. 500000.000 IN. 600000.000 IN. 750000.000 IN. 1000000.000 IN.

PARTS LIST			
QTY	ITEM	CODE	PART OR IDENTIFYING NUMBER
			UNLESS OTHERWISE SPECIFIED DIMENSIONS ARE IN INCHES TOLERANCES UNLESS SHOWN OTHERWISE ARE: .0005 IN. .001 IN. .002 IN. .005 IN. .010 IN. .015 IN. .030 IN. .050 IN. .100 IN. .150 IN. .300 IN. .500 IN. 1.000 IN. 1.500 IN. 2.000 IN. 3.000 IN. 4.000 IN. 5.000 IN. 6.000 IN. 8.000 IN. 10.000 IN. 12.000 IN. 15.000 IN. 20.000 IN. 25.000 IN. 30.000 IN. 40.000 IN. 50.000 IN. 60.000 IN. 75.000 IN. 100.000 IN. 125.000 IN. 150.000 IN. 200.000 IN. 250.000 IN. 300.000 IN. 400.000 IN. 500.000 IN. 600.000 IN. 750.000 IN. 1000.000 IN. 1250.000 IN. 1500.000 IN. 2000.000 IN. 2500.000 IN. 3000.000 IN. 4000.000 IN. 5000.000 IN. 6000.000 IN. 7500.000 IN. 10000.000 IN. 12500.000 IN. 15000.000 IN. 20000.000 IN. 25000.000 IN. 30000.000 IN. 40000.000 IN. 50000.000 IN. 60000.000 IN. 75000.000 IN. 100000.000 IN.

6-20

999975
 E
 B
 A
 30
 LM

LIST OF MATERIALS

DATE 07-02-79
P/N 0999975

820 RO Printer, 10 CPI

0101
REV A

PRINT ITEM NUMBER	QUANTITY PER ASSEMBLY	PART NUMBER	DESCRIPTION
0001	00001.000	0999690-0101	820 TERMINAL,BASIC-115V,10CPI
0004	00001.000	0999746-0001	PLENUM,PWB
0005	00001.000	0999747-0001	INSULATOR, SOUND AIR PLENUM
0006	00001.000	0999748-0001	COVER,TEST
0008	00001.000	0996704-0001	RIBBON,BLK MATRIX-SINGLE 60 YARD
0009	00001.000	0999854-9701	MANUAL, USER GUIDE
0010	00000.020	0996472-0001	PAPER,CPO-1 PART PREMIUM
0012	00001.000	0999456-9701	MANUAL,INFORMATION REQUEST FORM
0013	REF	0999760-9901	SHIPPING CONTAINER INDEX, 820 TRFM
0014	00001.000	0999457-9701	MANUAL,FIELD SERVICE FLYER
0016	REF	0999858-9701	INSTRUCTIONS, PACKING
0017	00001.000	0999860-9701	MANUAL, RIBBON & PAPER RECOMMENDATIONS
0018	00001.000	0999713-0001	WINDOW, TERMINAL
0023	00001.000	0994472-0001	SERVICE KIT,MODEL 810 PRINTER
0025	00001.000	0996289-0001	CORD SET,3-PIN PWR-DOMESTIC BLACK
0025A			ITEM 25 MAY BE USED AS AN
0025B			ALTERNATE FOR ITEM 26
0026	00000.000	0996289-0002	CORD SET,3-PIN PWR-DOMESTIC GRAY W/CLIP
0026A			ITEM 26 MAY BE USED AS AN
0026B			ALTERNATE FOR ITEM 25
0027	REF	0999883-0001	INTERCONNECTION DIAGRAM, 820 KSR
0028	00001.000	0999934-0001	CARD CARRIER ASSY
0029	00001.000	0999972-0001	CONTROL PANEL ASSY, 820 RO

LIST OF MATERIALS

DATE 07-02-79
P/N 0999975

820 RO Printer, 10 CPI

000 0201
REV A

PRINT ITEM NUMBER	QUANTITY PER ASSEMBLY	PART NUMBER	DESCRIPTION
0001	00001.000	0999690-0201	820 TERMINAL,BASIC-220V,10 CPI
0004	00001.000	0999746-0001	PLENUM,PWB
0005	00001.000	0999747-0001	INSULATOR, SOUND AIR PLENUM
0006	00001.000	0999748-0001	COVER,TEST
0008	00001.000	0996704-0001	RIBBON,BLK MATRIX-SINGLE 60 YARD
0009	00001.000	0999854-9701	MANUAL, USER GUIDE
0010	00000.020	0996472-0001	PAPER,CPO-1 PART PREMIUM
0012	00001.000	0999456-9701	MANUAL,INFORMATION REQUEST FORM
0013	REF	0999760-9901	SHIPPING CONTAINER INDEX, 820 TERM
0014	00001.000	0999457-9701	MANUAL,FIELD SERVICE FLYER
0016	REF	0999858-9701	INSTRUCTIONS, PACKING
0017	00001.000	0999860-9701	MANUAL, RIBBON & PAPER RECOMMENDATIONS
0018	00001.000	0999713-0001	WINDOW, TERMINAL
0023	00001.000	0994472-0001	SERVICE KIT,MODEL 810 PRINTER
0025	00001.000	0996290-0001	CORD SET,POWER-WEST EUROPEAN
0027	REF	0999883-0001	INTERCONNECTION DIAGRAM, 820 KSP
0028	00001.000	0999934-0001	CARD CARRIER ASSY
0029	00001.000	0999972-0001	CONTROL PANEL ASSY, 820 RO

LIST OF MATERIALS

DATE 07-02-79
P/N 0999975

820 RO Printer, 10 CPI

0401
REV A

PRINT ITEM NUMBER	QUANTITY PER ASSEMBLY	PART NUMBER	DESCRIPTION
0001	00001.000	0999690-0401	820 TERMINAL,BASIC-220V,10 CPI (BPO)
0004	00001.000	0999746-0001	PLENUM,PWB
0005	00001.000	0999747-0001	INSULATOR, SOUND AIR PLENUM
0006	00001.000	0999748-0001	COVER,TEST
0008	00001.000	0996704-0001	RIBBON,BLK MATRIX-SINGLE 60 YARD
0009	00001.000	0999854-9701	MANUAL, USER GUIDE
0010	00000.020	0996472-0001	PAPER,CPO-1 PART PREMIUM
0012	00001.000	0999456-9701	MANUAL,INFORMATION REQUEST FORM
0013	REF	0999760-9901	SHIPPING CONTAINER INDFX, 820 TERM
0014	00001.000	0999457-9701	MANUAL,FIELD SERVICE FLYER
0016	REF	0999858-9701	INSTRUCTIONS, PACKING
0017	00001.000	0999860-9701	MANUAL, RIBBON & PAPER RECOMMENDATIONS
0018	00001.000	0999713-0001	WINDOW, TERMINAL
0023	00001.000	0994472-0001	SERVICE KIT,MODEL 810 PRINTER
0025	00001.000	0996348-0001	CORD SET,PWR ,W/O CONN.,10 AMPS 3COND
0027	REF	0999883-0001	INTERCONNECTION DIAGRAM, 820 KSR
0028	00001.000	0999934-0001	CARD CARRIER ASSY
0029	00001.000	0999972-0001	CONTROL PANEL ASSY, 820 RO

LIST OF MATERIALS

DATE 06-18-79
P/N 0999980

820 RO Printer, 10/16 CPI

0101
REV A

PRINT ITEM NUMBER	QUANTITY PER ASSEMBLY	PART NUMBER	DESCRIPTION
0001	00001.000	0999690-0102	820 TERMINAL, BASIC-115V, 10/16CPI
0004	00001.000	0999746-0001	PLENUM, PWB
0005	00001.000	0999747-0001	INSULATOR, SOUND AIR PLENUM
0006	00001.000	0999749-0001	COVER, TEST
0008	00001.000	0996704-0001	PIRION, BLK MATRIX-SINGLE 60 YARD
0009	00001.000	0999854-9701	MANUAL, USER GUIDE
0010	00000.020	0996472-0001	PAPER, CPO-1 PART PREMIUM
0012	00001.000	0999456-9701	MANUAL, INFORMATION REQUEST FORM
0013	REF	0999760-9901	SHIPPING CONTAINER INDEX, 820 TERM
0014	00001.000	0999457-9701	MANUAL, FIELD SERVICE FLYER
0016	REF	0999858-9701	INSTRUCTIONS, PACKING
0017	00001.000	0999860-9701	MANUAL, PIRION & PAPER RECOMMENDATIONS
0018	00001.000	0999713-0001	WINDOW, TERMINAL
0023	00001.000	0994472-0001	SERVICE KIT, MODEL 810 PRINTER
0024	00001.000	0993205-0001	CABLE ASSY, 207/212 DATA SFT
0025	00001.000	0996289-0001	CORD SET, 3-PIN PWR-DOMESTIC BLACK
0026	00000.000	0996277-0002	CORD SET, 3-PIN PWR-DOMESTIC GRAY W/CLIP
0026A			ITEM 26 MAY BE USED AS AN
0026B			ALTERNATE FOR ITEM 25
0027	REF	0999883-0001	INTERCONNECTION DIAGRAM, 820 KSR
0028	00001.000	0999934-0001	CARD CARRIER ASSY
0029	00001.000	0999972-0001	CONTROL PANEL ASSY, 820 RO

LIST OF MATERIALS

DATE 06-18-79
P/N 0999980

820 RO Printer, 10/16 CPI

0201
REV A

PRINT ITEM NUMBER	QUANTITY PER ASSEMBLY	PART NUMBER	DESCRIPTION
0001	00001.000	0999690-0702	820 TERMINAL, BASIC-220V, 10/16 CPI
0004	00001.000	0999746-0001	PLENIUM, PWR
0005	00001.000	0999747-0001	INSULATOR, SOUND AIR PLENIUM
0006	00001.000	0999748-0001	COVER, TEST
0008	00001.000	0996704-0001	RIBBON, RLK MATRIX-SINGLE 60 YARD
0009	00001.000	0999854-9701	MANUAL, USER GUIDE
0010	00000.020	0996472-0001	PAPER, CPD-1 PART PREMIUM
0012	00001.000	0999456-9701	MANUAL, INFORMATION REQUEST FORM
0013	REF	0999760-9901	SHIPPING CONTAINER INDEX, 820 TERM
0014	00001.000	0999457-9701	MANUAL, FIELD SERVICE FLYER
0016	REF	0999858-9701	INSTRUCTIONS, PACKING
0017	00001.000	0999860-9701	MANUAL, RIBBON & PAPER RECOMMENDATIONS
0018	00001.000	0999713-0001	WINDOW, TERMINAL
0023	00001.000	0994472-0001	SERVICE KIT, MODEL 810 PRINTER
0024	00001.000	0993205-0001	CABLE ASSY, 2027/212 DATA SET
0026	00001.000	0996290-0001	CORD SET, POWER-WEST EUROPEAN
0027	REF	0999883-0001	INTERCONNECTION DIAGRAM, 820 KSR
0028	00001.000	0999934-0001	CARD CARRIER ASSY
0029	00001.000	0999972-0001	CONTROL PANEL ASSY, 820 RO

NOTES

1 THE WINDOW SHALL BE FREE OF ANY OBVIOUS FLAWS AND SCRATCHES WHEN VIEWED FROM A DISTANCE OF 2 FEET AND HAVING A NORMAL VIEWING ANGLE OF 30° OVERHEAD LIGHTING HAVING 75 TO 100 FOOT CANDLES IS REQUIRED WITH AN INSPECTION TIME PER WINDOW OF 4 SECONDS. WINDOW MUST BE PROPERLY ASSEMBLED IN THE COV. 2 WITH THE BACKGROUND BEING 152 COLUMN OF PRINTED GASDERPOLE TEXT.

2 INSTALL ITEM 28 IN SOCKET U12 ON THE PRINTED WIRING BOARD ASSEMBLY

REV	DATE	APPROVED
A	04/23/64	C. Brown
LM-0201	ITEM 25	11/5/74

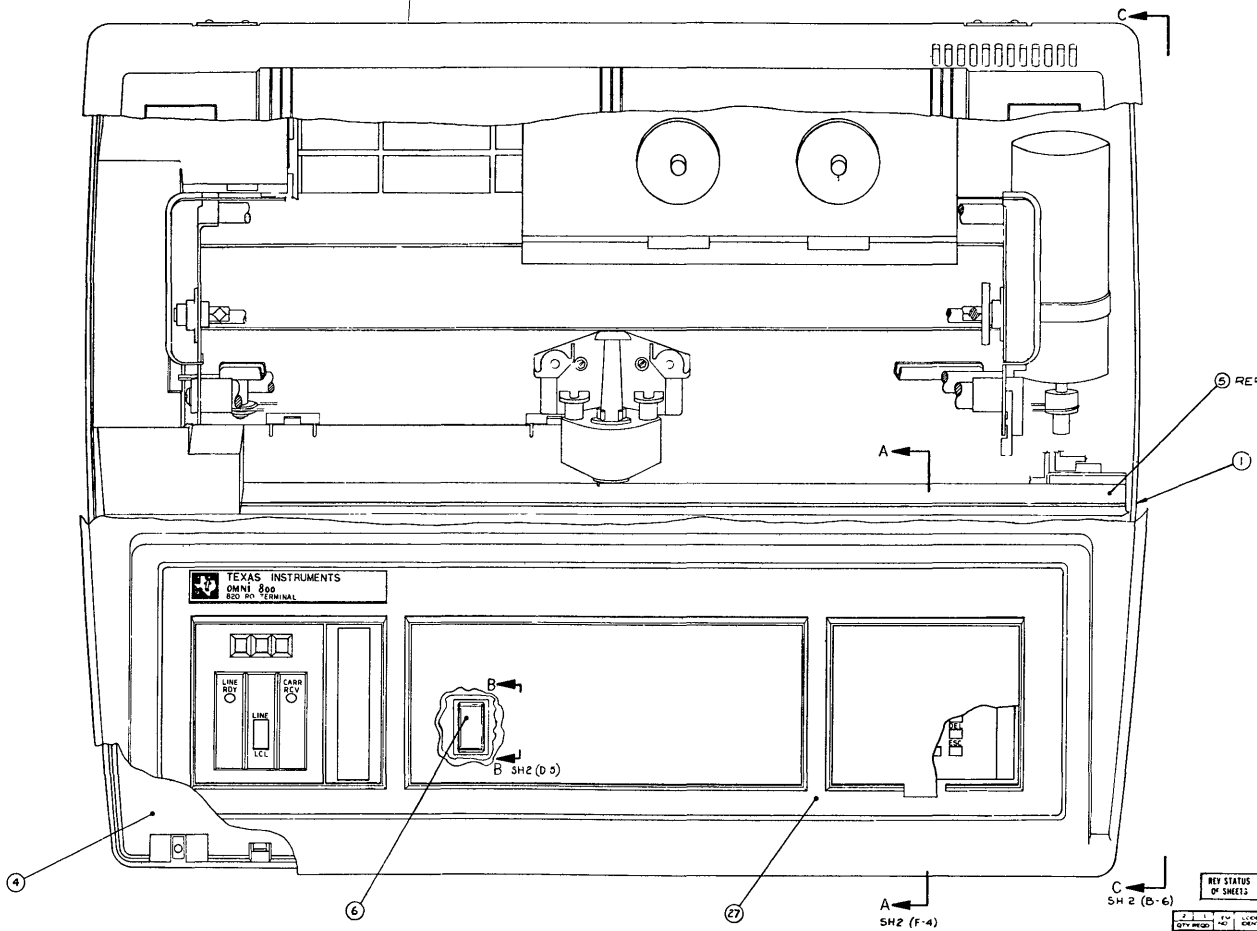

PART NUMBER	DESCRIPTION
999979 0201	820 RO PACKAGE, 220V, 10/16 CPI
999979-0101	820 RO PACKAGE, 110V, 10/16 CPI

REV	STATUS	REV	A	X
1	SM	1	2	

UNLESS OTHERWISE SPECIFIED		UNLESS OTHERWISE SPECIFIED		UNLESS OTHERWISE SPECIFIED	
REMOVE ALL BURRS AND SHARP EDGES	FINISH TO 250 P.S.I.	FINISH TO 250 P.S.I.	FINISH TO 250 P.S.I.	FINISH TO 250 P.S.I.	FINISH TO 250 P.S.I.
REMOVE ALL BURRS AND SHARP EDGES	FINISH TO 250 P.S.I.	FINISH TO 250 P.S.I.	FINISH TO 250 P.S.I.	FINISH TO 250 P.S.I.	FINISH TO 250 P.S.I.
REMOVE ALL BURRS AND SHARP EDGES	FINISH TO 250 P.S.I.	FINISH TO 250 P.S.I.	FINISH TO 250 P.S.I.	FINISH TO 250 P.S.I.	FINISH TO 250 P.S.I.

6-29

H
H
23
G
F
E
D
C
B
A

L.V.

6-30

797

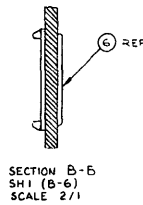
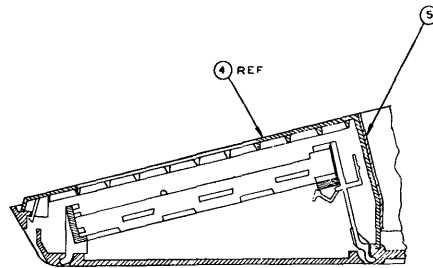
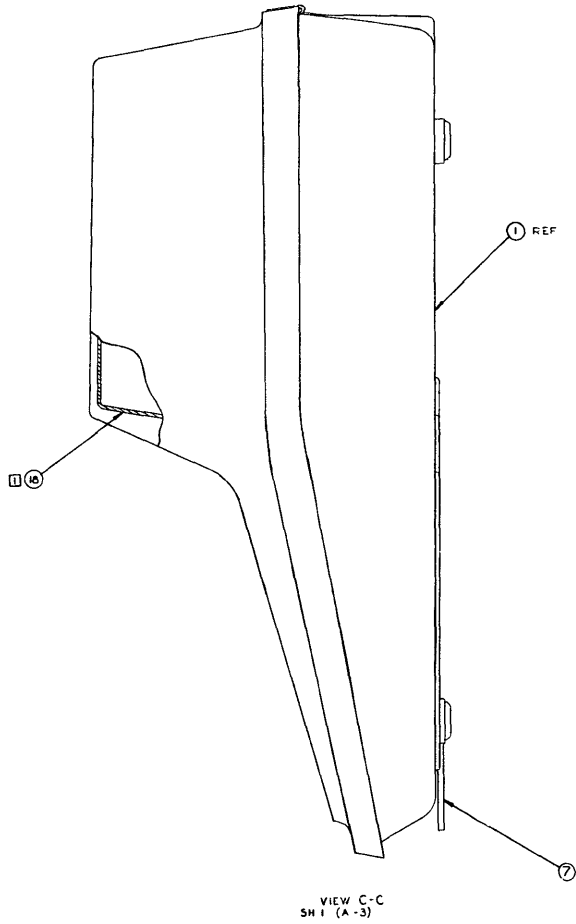

REV	DATE	DESCRIPTION	BY	CHKD

UNLESS OTHERWISE SPECIFIED	UNLESS OTHERWISE SPECIFIED	DATE	BY
REMOVE ALL BURRS AND SHARP EDGES	DIMENSIONS ARE IN INCHES		
FINISH SURFACES AS SHOWN	TOLERANCE		
DIMENSIONS TO FACE UNLESS OTHERWISE SPECIFIED	FRACTIONS		
BEFORE FINAL FINISHING	DECIMALS		
CONVERTING TO METRIC DIMENSIONS	FRACTIONS		
CONVERTING TO METRIC DIMENSIONS	DECIMALS		
ALTERATIONS ORDERED IN ACCORDANCE WITH THIS SPECIFICATION	FRACTIONS		
	DECIMALS		

HOLE TOLERANCES DIA - .001 DIA - .002 DIA - .003 DIA - .004 DIA - .005 DIA - .006 DIA - .007 DIA - .008 DIA - .009 DIA - .010	HOLE TOLERANCES DIA - .001 DIA - .002 DIA - .003 DIA - .004 DIA - .005 DIA - .006 DIA - .007 DIA - .008 DIA - .009 DIA - .010	HOLE TOLERANCES DIA - .001 DIA - .002 DIA - .003 DIA - .004 DIA - .005 DIA - .006 DIA - .007 DIA - .008 DIA - .009 DIA - .010	HOLE TOLERANCES DIA - .001 DIA - .002 DIA - .003 DIA - .004 DIA - .005 DIA - .006 DIA - .007 DIA - .008 DIA - .009 DIA - .010
---	---	---	---

MATERIAL PART NO. QUANTITY APPLICATION	DRAWING NO. DATE BY CHKD	TITLE DATE BY CHKD	DRAWING NO. DATE BY CHKD
---	-----------------------------------	-----------------------------	-----------------------------------

TEXAS INSTRUMENTS INSTRUMENT DIVISION 12000 TI BLDG DALLAS, TEXAS 75243	DRAWING NO. DATE BY CHKD	TITLE DATE BY CHKD	DRAWING NO. DATE BY CHKD
--	-----------------------------------	-----------------------------	-----------------------------------

5
H
23
G
F
E
D
C
B
A

REV
E: 96214
999979
SCALE 1/1
SHEET 2

LIST OF MATERIALS

DATE 06-18-79
P/N 0999979

820 RO Package, 10/16 CPI

0101
REV A

PRINT ITEM NUMBER	QUANTITY PER ASSEMBLY	PART NUMBER	DESCRIPTION
0001	00001.000	0999690-0102	820 TERMINAL, BASIC-115V, 10/16CPI
0004	00001.000	0999746-0001	PLENUM, PWR
0005	00001.000	0999747-0001	INSULATOR, SOUND AIR PLENUM
0006	00001.000	0999748-0001	COVER, TEST
0007	00001.000	0999934-0001	CARD CARRIER ASSY
0008	00001.000	0996704-0001	RIBBON, BLK MATRIX-SINGLE 60 YARD
0009	00001.000	0999854-9701	MANUAL, USER GUIDE
0010	00000.020	0996472-0001	PAPER, CPD-1 PART PREMIUM
0012	00001.000	0999456-9701	MANUAL, INFORMATION REQUEST FORM
0013	REF	0999760-9901	SHIPPING CONTAINER INDEX, 820 TERM
0014	00001.000	0999457-9701	MANUAL, FIELD SERVICE FLYER
0016	REF	0999858-9701	INSTRUCTIONS, PACKING
0017	00001.000	0999860-9701	MANUAL, RIBBON & PAPER RECOMMENDATIONS
0018	00001.000	0999713-0001	WINDOW, TERMINAL
0023	00001.000	0994472-0001	SERVICE KIT, MODEL 810 PRINTER
0024	00001.000	0993205-0001	CABLE ASSY, 202/212 DATA SET
0025	00001.000	0996289-001	CORD SET, 3-PIN PWR-DOME. IC BLACK
0026	00000.000	0996289-0002	CORD SET, 3-PIN PWR-DOMESTIC GRAY W/CLIP
0026A			ITEM 26 MAY BE USED AS AN
0026B			ALTERNATE FOR ITEM 25
0027	00001.000	0999972-0001	CONTROL PANEL ASSY, 820 RO
0028	00001.000	0999978-0001	KIT, DEVICE/FORM CONTROL

LIST OF MATERIALS

DATE 06-18-79
P/N 0999979

820 RO Package, 10/16 CPI

0201
REV A

PRINT ITEM NUMBER	QUANTITY PER ASSEMBLY	PART NUMBER	DESCRIPTION
0001	00001.000	0999690-0202	820 TERMINAL, BASIC-220V, 10/16 CPI
0004	00001.000	0999746-0001	PLENUM, PWB
0005	00001.000	0999747-0001	INSULATOR, SOUND AIR PLENUM
0006	00001.000	0999748-0001	COVER, TEST
0007	00001.000	0999934-0001	CARD CARRIER ASSY
0008	00001.000	0996704-0001	RIBBON, BLK MATRIX-SINGLE 60 YARD
0009	00001.000	0999854-9701	MANUAL, USER GUIDE
0010	00000.020	0996472-0001	PAPER, CPO-1 PART PREMIUM
0012	00001.000	0999456-9701	MANUAL, INFORMATION REQUEST FORM
0013	REF	0999760-9901	SHIPPING CONTAINER INDEX, 820 TERM
0014	00001.000	0999457-9701	MANUAL, FIELD SERVICE FLYER
0016	REF	0999858-9701	INSTRUCTIONS, PACKING
0017	00001.000	0999860-9701	MANUAL, RIBBON & PAPER RECOMMENDATIONS
0018	00001.000	0999713-0001	WINDOW, TERMINAL
0023	00001.000	0996472-0001	SERVICE KIT, MODEL 810 PRINTER
0024	00001.000	0993205-0001	CABLE ASSY, 202/212 DATA SET
0025	00001.000	0996290-0001	CORD SET, POWER-WEST EUROPEAN
0027	00001.000	0999972-0001	CONTROL PANFL ASSY, 820 RO
0028	00001.000	0999978-0001	KIT, DEVICE/FORM CONTROL

NOTES

- 1 PIN NUMBERS ON CABLE CONNECTOR, P31, DO NOT AGREE WITH PIN NUMBERS ON EMULATOR BOARD & ITS CONNECTOR, J31, P31 PIN 39 CONNECTS TO J31 PIN 1.
- 2 APPLY ADHESIVE (ITEM 80) BETWEEN EDGES OF ITEM 39 CARD CARRIER SUPPORT AND RIBS ON ITEM 11 TERMINAL BASE OVER LENGTH INDICATED. USE EDWARDS PASTE.
- 3 DISCARD ON/OFF PLATE SUPPLIED WITH ITEM 16 AND USE ITEM 85.
- 4 1/4" AND .040" ASSEMBLED SOLDER BR LAD WIRE (1 - 1/4" & 1/4" PLY P.C.T. AND REF. VEC. 0114) IN 1/16"

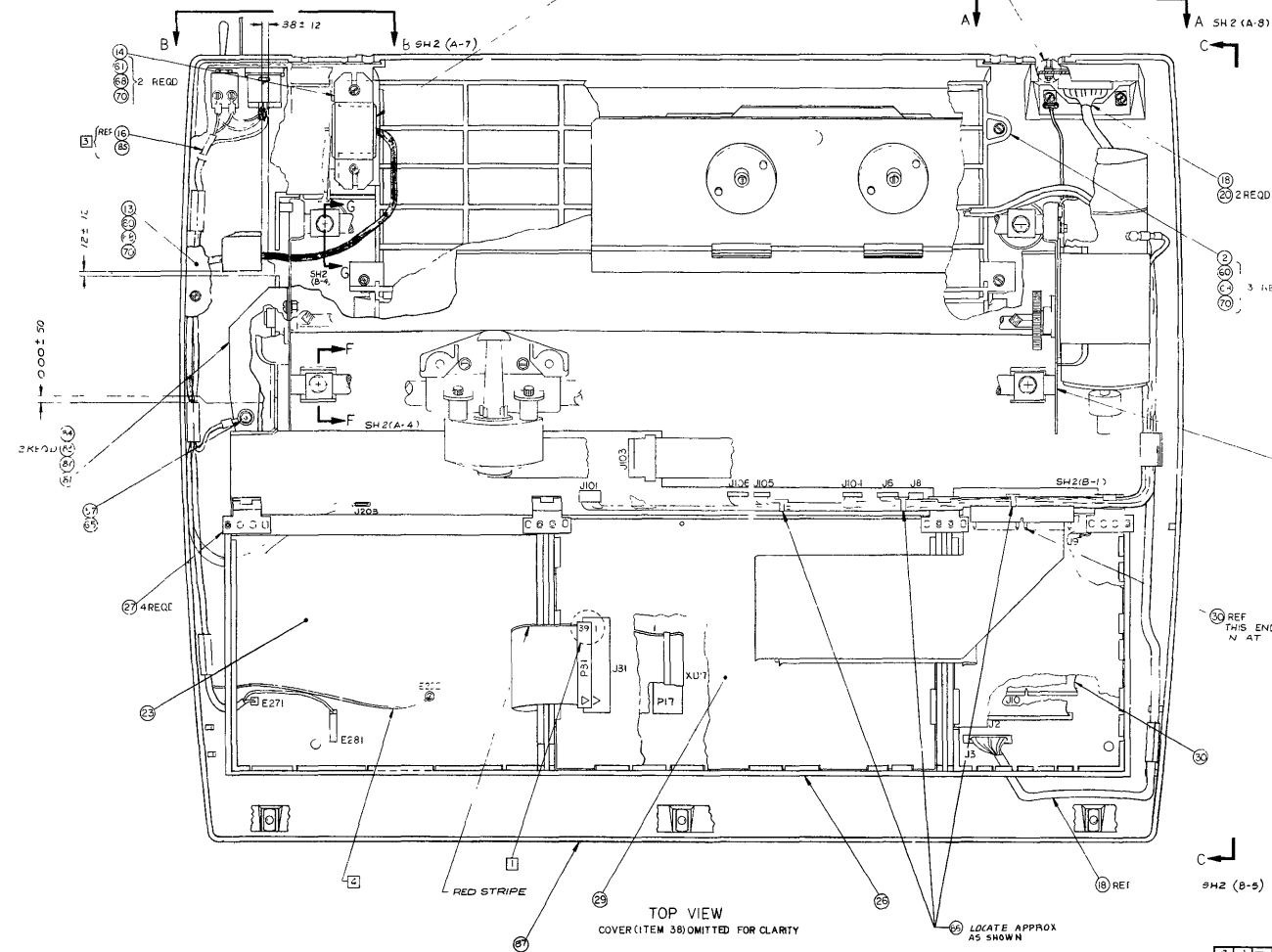

PART NUMBER	DESCRIPTION
999690-0202	820 TERMINAL, BASIC - 115V, 10/16CPI
999690-0201	820 TERMINAL, BASIC - 120V, 10CPI
999690-0102	820 TERMINAL, BASIC - 115V, 10/16CPI
999690-0101	820 TERMINAL, BASIC - 115V, 10CPI

REV STATUS REV IS IN IN QTY REQD

REV	STATUS	REV IS IN IN	QTY REQD
1	Q	1	1
2	Q	1	1
3	Q	1	1
4	Q	1	1
5	Q	1	1
6	Q	1	1
7	Q	1	1
8	Q	1	1
9	Q	1	1
10	Q	1	1
11	Q	1	1
12	Q	1	1
13	Q	1	1
14	Q	1	1
15	Q	1	1
16	Q	1	1
17	Q	1	1
18	Q	1	1
19	Q	1	1
20	Q	1	1
21	Q	1	1
22	Q	1	1
23	Q	1	1
24	Q	1	1
25	Q	1	1
26	Q	1	1
27	Q	1	1
28	Q	1	1
29	Q	1	1
30	Q	1	1

1	SLOK	127-02	00
2	127-02	00	00
3	127-02	00	00
4	127-02	00	00

6-33

820 TERMINAL, BASIC

E 96214 999690

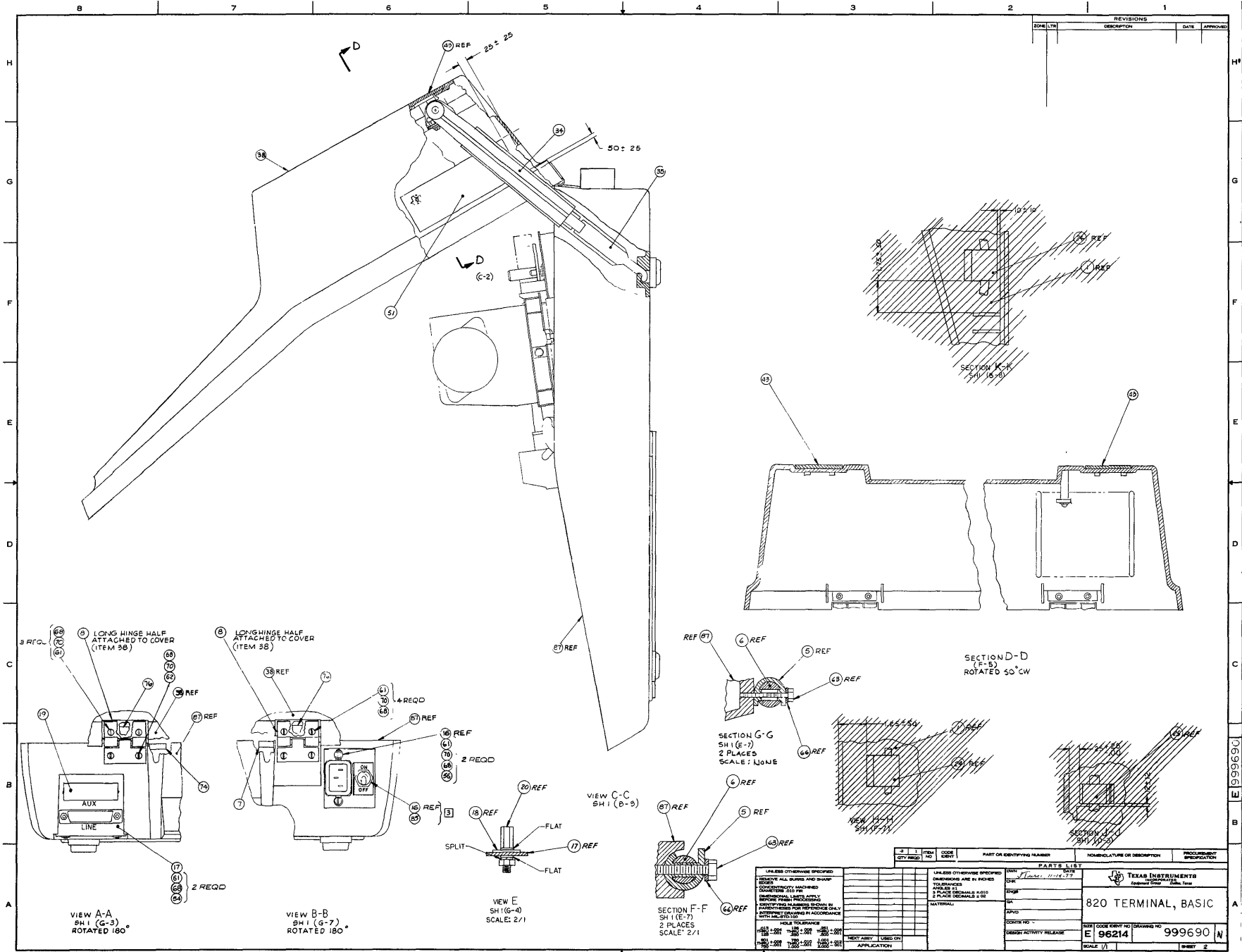

999690

REV	ITM	NO	CODE	DATE	PART OR IDENTIFYING NUMBER	DESCRIPTION	PREPARED BY	APPROVED

UNLESS OTHERWISE SPECIFIED:		PARTS LIST	
1. FINISH: ALL SURFS AND SWAMP	2. DIMENSIONS ARE IN INCHES	DATE: 1/16/57	TEXAS INSTRUMENTS
3. TOLERANCES:	4. MATERIAL:	DESIGNER: J. L. ...	820 TERMINAL, BASIC
FRACTIONS DECIMALS	5. FINISH: ALL SURFS AND SWAMP	DATE: 1/16/57	820 TERMINAL, BASIC
1/16 0.0625 0.001	6. DIMENSIONS ARE IN INCHES	DESIGNER: J. L. ...	820 TERMINAL, BASIC
1/8 0.125 0.001	7. TOLERANCES:	DATE: 1/16/57	820 TERMINAL, BASIC
3/16 0.1875 0.001	8. MATERIAL:	DESIGNER: J. L. ...	820 TERMINAL, BASIC
1/4 0.250 0.001	9. FINISH: ALL SURFS AND SWAMP	DATE: 1/16/57	820 TERMINAL, BASIC
5/16 0.3125 0.001	10. DIMENSIONS ARE IN INCHES	DESIGNER: J. L. ...	820 TERMINAL, BASIC
3/8 0.375 0.001	11. TOLERANCES:	DATE: 1/16/57	820 TERMINAL, BASIC
7/16 0.4375 0.001	12. MATERIAL:	DESIGNER: J. L. ...	820 TERMINAL, BASIC
1/2 0.500 0.001	13. FINISH: ALL SURFS AND SWAMP	DATE: 1/16/57	820 TERMINAL, BASIC
5/8 0.625 0.001	14. DIMENSIONS ARE IN INCHES	DESIGNER: J. L. ...	820 TERMINAL, BASIC
3/4 0.750 0.001	15. TOLERANCES:	DATE: 1/16/57	820 TERMINAL, BASIC
7/8 0.875 0.001	16. MATERIAL:	DESIGNER: J. L. ...	820 TERMINAL, BASIC
1 1.000 0.001	17. FINISH: ALL SURFS AND SWAMP	DATE: 1/16/57	820 TERMINAL, BASIC
1 1/8 1.125 0.001	18. DIMENSIONS ARE IN INCHES	DESIGNER: J. L. ...	820 TERMINAL, BASIC
1 1/4 1.250 0.001	19. TOLERANCES:	DATE: 1/16/57	820 TERMINAL, BASIC
1 3/8 1.375 0.001	20. MATERIAL:	DESIGNER: J. L. ...	820 TERMINAL, BASIC
1 1/2 1.500 0.001	21. FINISH: ALL SURFS AND SWAMP	DATE: 1/16/57	820 TERMINAL, BASIC
1 5/8 1.625 0.001	22. DIMENSIONS ARE IN INCHES	DESIGNER: J. L. ...	820 TERMINAL, BASIC
1 3/4 1.750 0.001	23. TOLERANCES:	DATE: 1/16/57	820 TERMINAL, BASIC
1 7/8 1.875 0.001	24. MATERIAL:	DESIGNER: J. L. ...	820 TERMINAL, BASIC
2 2.000 0.001	25. FINISH: ALL SURFS AND SWAMP	DATE: 1/16/57	820 TERMINAL, BASIC
2 1/8 2.125 0.001	26. DIMENSIONS ARE IN INCHES	DESIGNER: J. L. ...	820 TERMINAL, BASIC
2 1/4 2.250 0.001	27. TOLERANCES:	DATE: 1/16/57	820 TERMINAL, BASIC
2 3/8 2.375 0.001	28. MATERIAL:	DESIGNER: J. L. ...	820 TERMINAL, BASIC
2 1/2 2.500 0.001	29. FINISH: ALL SURFS AND SWAMP	DATE: 1/16/57	820 TERMINAL, BASIC
2 5/8 2.625 0.001	30. DIMENSIONS ARE IN INCHES	DESIGNER: J. L. ...	820 TERMINAL, BASIC
2 3/4 2.750 0.001	31. TOLERANCES:	DATE: 1/16/57	820 TERMINAL, BASIC
2 7/8 2.875 0.001	32. MATERIAL:	DESIGNER: J. L. ...	820 TERMINAL, BASIC
3 3.000 0.001	33. FINISH: ALL SURFS AND SWAMP	DATE: 1/16/57	820 TERMINAL, BASIC
3 1/8 3.125 0.001	34. DIMENSIONS ARE IN INCHES	DESIGNER: J. L. ...	820 TERMINAL, BASIC
3 1/4 3.250 0.001	35. TOLERANCES:	DATE: 1/16/57	820 TERMINAL, BASIC
3 3/8 3.375 0.001	36. MATERIAL:	DESIGNER: J. L. ...	820 TERMINAL, BASIC
3 1/2 3.500 0.001	37. FINISH: ALL SURFS AND SWAMP	DATE: 1/16/57	820 TERMINAL, BASIC
3 5/8 3.625 0.001	38. DIMENSIONS ARE IN INCHES	DESIGNER: J. L. ...	820 TERMINAL, BASIC
3 3/4 3.750 0.001	39. TOLERANCES:	DATE: 1/16/57	820 TERMINAL, BASIC
3 7/8 3.875 0.001	40. MATERIAL:	DESIGNER: J. L. ...	820 TERMINAL, BASIC
4 4.000 0.001	41. FINISH: ALL SURFS AND SWAMP	DATE: 1/16/57	820 TERMINAL, BASIC
4 1/8 4.125 0.001	42. DIMENSIONS ARE IN INCHES	DESIGNER: J. L. ...	820 TERMINAL, BASIC
4 1/4 4.250 0.001	43. TOLERANCES:	DATE: 1/16/57	820 TERMINAL, BASIC
4 3/8 4.375 0.001	44. MATERIAL:	DESIGNER: J. L. ...	820 TERMINAL, BASIC
4 1/2 4.500 0.001	45. FINISH: ALL SURFS AND SWAMP	DATE: 1/16/57	820 TERMINAL, BASIC
4 5/8 4.625 0.001	46. DIMENSIONS ARE IN INCHES	DESIGNER: J. L. ...	820 TERMINAL, BASIC
4 3/4 4.750 0.001	47. TOLERANCES:	DATE: 1/16/57	820 TERMINAL, BASIC
4 7/8 4.875 0.001	48. MATERIAL:	DESIGNER: J. L. ...	820 TERMINAL, BASIC
5 5.000 0.001	49. FINISH: ALL SURFS AND SWAMP	DATE: 1/16/57	820 TERMINAL, BASIC
5 1/8 5.125 0.001	50. DIMENSIONS ARE IN INCHES	DESIGNER: J. L. ...	820 TERMINAL, BASIC
5 1/4 5.250 0.001	51. TOLERANCES:	DATE: 1/16/57	820 TERMINAL, BASIC
5 3/8 5.375 0.001	52. MATERIAL:	DESIGNER: J. L. ...	820 TERMINAL, BASIC
5 1/2 5.500 0.001	53. FINISH: ALL SURFS AND SWAMP	DATE: 1/16/57	820 TERMINAL, BASIC
5 5/8 5.625 0.001	54. DIMENSIONS ARE IN INCHES	DESIGNER: J. L. ...	820 TERMINAL, BASIC
5 3/4 5.750 0.001	55. TOLERANCES:	DATE: 1/16/57	820 TERMINAL, BASIC
5 7/8 5.875 0.001	56. MATERIAL:	DESIGNER: J. L. ...	820 TERMINAL, BASIC
6 6.000 0.001	57. FINISH: ALL SURFS AND SWAMP	DATE: 1/16/57	820 TERMINAL, BASIC
6 1/8 6.125 0.001	58. DIMENSIONS ARE IN INCHES	DESIGNER: J. L. ...	820 TERMINAL, BASIC
6 1/4 6.250 0.001	59. TOLERANCES:	DATE: 1/16/57	820 TERMINAL, BASIC
6 3/8 6.375 0.001	60. MATERIAL:	DESIGNER: J. L. ...	820 TERMINAL, BASIC
6 1/2 6.500 0.001	61. FINISH: ALL SURFS AND SWAMP	DATE: 1/16/57	820 TERMINAL, BASIC
6 5/8 6.625 0.001	62. DIMENSIONS ARE IN INCHES	DESIGNER: J. L. ...	820 TERMINAL, BASIC
6 3/4 6.750 0.001	63. TOLERANCES:	DATE: 1/16/57	820 TERMINAL, BASIC
6 7/8 6.875 0.001	64. MATERIAL:	DESIGNER: J. L. ...	820 TERMINAL, BASIC
7 7.000 0.001	65. FINISH: ALL SURFS AND SWAMP	DATE: 1/16/57	820 TERMINAL, BASIC
7 1/8 7.125 0.001	66. DIMENSIONS ARE IN INCHES	DESIGNER: J. L. ...	820 TERMINAL, BASIC
7 1/4 7.250 0.001	67. TOLERANCES:	DATE: 1/16/57	820 TERMINAL, BASIC
7 3/8 7.375 0.001	68. MATERIAL:	DESIGNER: J. L. ...	820 TERMINAL, BASIC
7 1/2 7.500 0.001	69. FINISH: ALL SURFS AND SWAMP	DATE: 1/16/57	820 TERMINAL, BASIC
7 5/8 7.625 0.001	70. DIMENSIONS ARE IN INCHES	DESIGNER: J. L. ...	820 TERMINAL, BASIC
7 3/4 7.750 0.001	71. TOLERANCES:	DATE: 1/16/57	820 TERMINAL, BASIC
7 7/8 7.875 0.001	72. MATERIAL:	DESIGNER: J. L. ...	820 TERMINAL, BASIC
8 8.000 0.001	73. FINISH: ALL SURFS AND SWAMP	DATE: 1/16/57	820 TERMINAL, BASIC
8 1/8 8.125 0.001	74. DIMENSIONS ARE IN INCHES	DESIGNER: J. L. ...	820 TERMINAL, BASIC
8 1/4 8.250 0.001	75. TOLERANCES:	DATE: 1/16/57	820 TERMINAL, BASIC
8 3/8 8.375 0.001	76. MATERIAL:	DESIGNER: J. L. ...	820 TERMINAL, BASIC
8 1/2 8.500 0.001	77. FINISH: ALL SURFS AND SWAMP	DATE: 1/16/57	820 TERMINAL, BASIC
8 5/8 8.625 0.001	78. DIMENSIONS ARE IN INCHES	DESIGNER: J. L. ...	820 TERMINAL, BASIC
8 3/4 8.750 0.001	79. TOLERANCES:	DATE: 1/16/57	820 TERMINAL, BASIC
8 7/8 8.875 0.001	80. MATERIAL:	DESIGNER: J. L. ...	820 TERMINAL, BASIC
9 9.000 0.001	81. FINISH: ALL SURFS AND SWAMP	DATE: 1/16/57	820 TERMINAL, BASIC
9 1/8 9.125 0.001	82. DIMENSIONS ARE IN INCHES	DESIGNER: J. L. ...	820 TERMINAL, BASIC
9 1/4 9.250 0.001	83. TOLERANCES:	DATE: 1/16/57	820 TERMINAL, BASIC
9 3/8 9.375 0.001	84. MATERIAL:	DESIGNER: J. L. ...	820 TERMINAL, BASIC
9 1/2 9.500 0.001	85. FINISH: ALL SURFS AND SWAMP	DATE: 1/16/57	820 TERMINAL, BASIC
9 5/8 9.625 0.001	86. DIMENSIONS ARE IN INCHES	DESIGNER: J. L. ...	820 TERMINAL, BASIC
9 3/4 9.750 0.001	87. TOLERANCES:	DATE: 1/16/57	820 TERMINAL, BASIC
9 7/8 9.875 0.001	88. MATERIAL:	DESIGNER: J. L. ...	820 TERMINAL, BASIC
10 10.000 0.001	89. FINISH: ALL SURFS AND SWAMP	DATE: 1/16/57	820 TERMINAL, BASIC
10 1/8 10.125 0.001	90. DIMENSIONS ARE IN INCHES	DESIGNER: J. L. ...	820 TERMINAL, BASIC
10 1/4 10.250 0.001	91. TOLERANCES:	DATE: 1/16/57	820 TERMINAL, BASIC
10 3/8 10.375 0.001	92. MATERIAL:	DESIGNER: J. L. ...	820 TERMINAL, BASIC
10 1/2 10.500 0.001	93. FINISH: ALL SURFS AND SWAMP	DATE: 1/16/57	820 TERMINAL, BASIC
10 5/8 10.625 0.001	94. DIMENSIONS ARE IN INCHES	DESIGNER: J. L. ...	820 TERMINAL, BASIC
10 3/4 10.750 0.001	95. TOLERANCES:	DATE: 1/16/57	820 TERMINAL, BASIC
10 7/8 10.875 0.001	96. MATERIAL:	DESIGNER: J. L. ...	820 TERMINAL, BASIC
11 11.000 0.001	97. FINISH: ALL SURFS AND SWAMP	DATE: 1/16/57	820 TERMINAL, BASIC
11 1/8 11.125 0.001	98. DIMENSIONS ARE IN INCHES	DESIGNER: J. L. ...	820 TERMINAL, BASIC
11 1/4 11.250 0.001	99. TOLERANCES:	DATE: 1/16/57	820 TERMINAL, BASIC
11 3/8 11.375 0.001	100. MATERIAL:	DESIGNER: J. L. ...	820 TERMINAL, BASIC

6-35

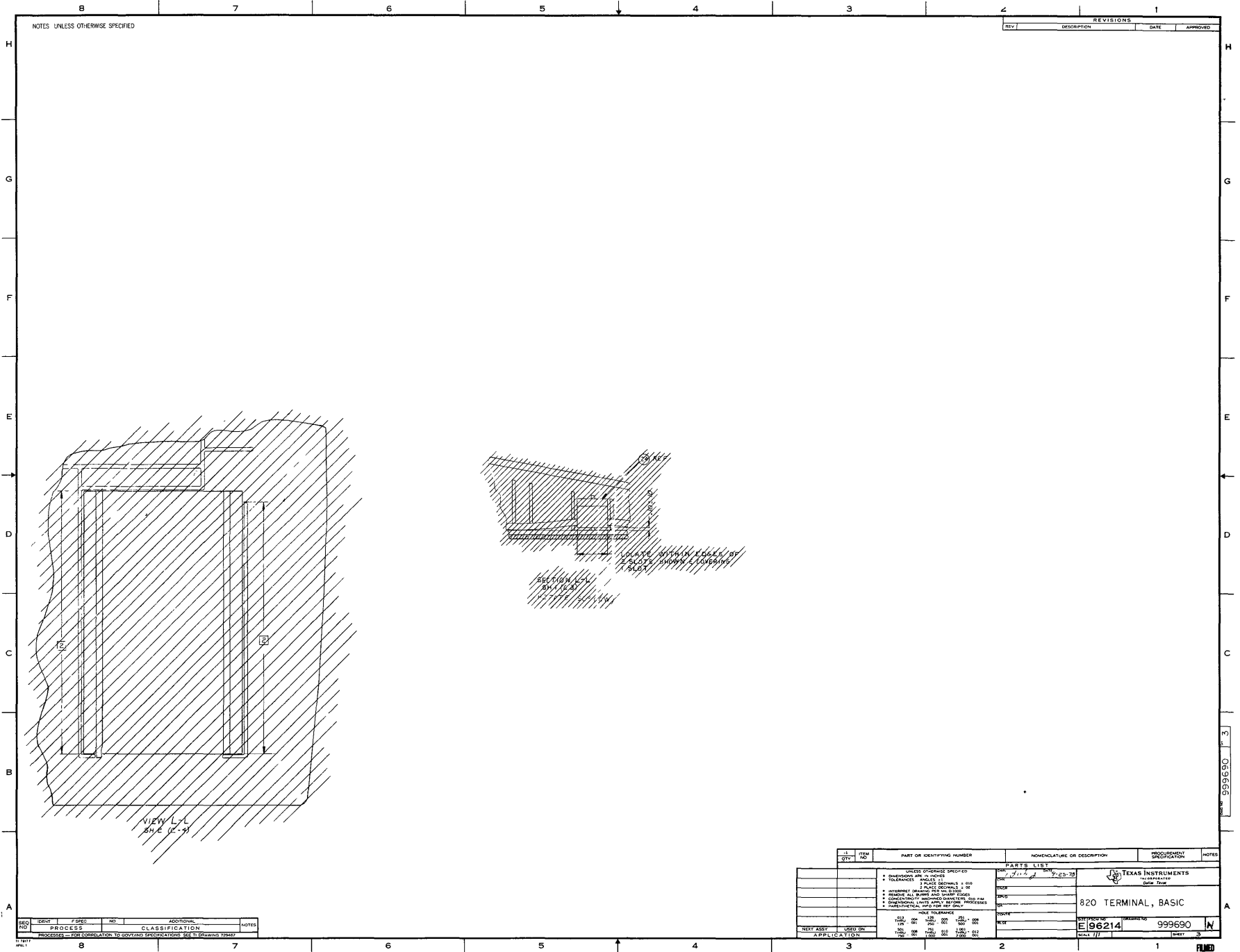

NOTES UNLESS OTHERWISE SPECIFIED

REVISIONS			
REV	DESCRIPTION	DATE	APPROVED

REV	DATE	PROCESS	NO	ADDITIONAL CLASSIFICATION	NOTES

QTY	ITEM	PART OR IDENTIFYING NUMBER	NOMENCLATURE OR DESCRIPTION	REQUIREMENT SPECIFICATION	NOTES

UNLESS OTHERWISE SPECIFIED
 DIMENSIONS ARE IN INCHES
 TOLERANCES UNLESS INDICATED AS FOLLOWS:
 • FRACTIONS .010
 • DECIMALS .010
 • ANGLES .010
 • HOLE TOLERANCES:
 H11 D9
 H8 D8
 H7 D7
 H6 D6
 H5 D5
 H4 D4
 H3 D3
 H2 D2
 H1 D1

TEXAS INSTRUMENTS
 CORPORATION
 Dallas, Texas
 820 TERMINAL, BASIC
 E 96214 999690 N
 SHEET 1/1

FILED

LIST OF MATERIALS

DATE 07-12-79
P/N 0999690

820 Terminal, Basic - 115 V, 10CPI

0101
REV R

PRINT ITEM NUMBER	QUANTITY PER ASSEMBLY	PART NUMBER	DESCRIPTION
0002	00001.000	0999739-0001	COVER, PAPER CHUTE
0005	00004.000	0999885-0001	SHOCK MOUNT
0006	00001.000	0999689-0001	MECHANISM, 10 CPI
0007	00001.000	0999740-0001	NUTPLATE,HINGE-LEFT TERMINAL BASE
0008	00002.000	0999741-0001	HINGE, TERMINAL COVER
0012	00001.000	0999819-0001	FAN ASSEMBLY
0013	00001.000	0999720-0001	PLENUM, FAN
0014	00001.000	0983863-0001	BRACKET,FAN MOTOR
0016	00001.000	0999835-0001	CABLE ASSY, POWER DISTRIBUTION
0017	00001.000	0999743-0001	PANFL, EIA CABLE
0018	00001.000	0999742-0001	CABLE ASSEMBLY, EIA (INTERNAL)
0019	00001.000	0999781-0001	COVER, EIA CABLE PANEL
0020	00002.000	0808129-0001	CONNECTOR,ELECT SCREW-LOCK ASSY FEMALE
0023	00001.000	0999820-0101	TERMINAL ELECTRONICS W/GND PLANE-115V
0026	00001.000	0999744-0001	CARD FRAME, KEYBOARD/OPTION
0027	00004.000	0999745-0001	KEEPER, CARD FRAME
0029	00001.000	0999903-0001	KIT,EMULATOF-DECREMENTER
0030	00001.000	0996774-0002	CABLE,ELEC,8.50LG FLAT,FLEXIBLE
0034	00001.000	0999749-0001	STAY, EXTERNAL
0035	00001.000	0999750-0001	STAY, INTERNAL
0038	00001.000	0999918-0001	COVER ASSY
0043	00002.000	0999762-0001	COVER, FALSE-ASR TERMINAL
0051	00001.000	0999833-0001	IDENTIFICATION KIT
0054	00002.000	0972734-0001	TERMINAL,ELECTRICAL,TAB-.250 INCH
0056	00002.000	0411115-0044	NUT,4-40 HEXAGON CRES STEEL
0057	00001.000	0411115-0084	NUT,PLAIN 8-32 UNC-2B HEX CRES
0060	00004.000	0972988-0014	SCREW 4-40 X .312 PAN HEAD CRES
0061	00013.000	0972988-0016	SCREW 4-40 X .438 PAN HEAD CRES
0062	00001.000	0972988-0018	SCREW 4-40 X .625 PAN HEAD CRES
0063	00004.000	2210071-0024	SCREW,8-32 X 1" MACHINE,HEX HEAD
0065	00001.000	0411101-0059	LOCKWASHER # 8 EXTERNAL TOOTH CRES
0066	00004.000	0416622-0024	WASHER #8 FLAT
0068	00018.000	0411104-0135	WASHER, LOCK-SPRING, HELICAL, #4
0070	00016.000	0416622-0011	WASHER #4 FLAT
0074	00001.000	0999792-0001	NUTPLATE,HINGE-RH TERMINAL BASE
0076	00002.000	0999793-0001	NUTPLATE,HINGE- TERMINAL COVER
0078	REF	0999833-9901	INTERCONNECTION DIAG 820 KSR
0081	00001.000	0999927-0001	GROUND STRAP MECHANISM
0082	00001.000	0972988-0027	SCREW 6-32 X .312 PAN HEAD CRES
0083	00002.000	0411101-0058	LOCKWASHER #6 EXTERNAL TOOTH CRES

LIST OF MATERIALS

DATE 07-12-79
P/N 0999690

820 Terminal, Basic - 115 V, 10CPI

REV 0101
R

PRINT ITEM NUMBER	QUANTITY PER ASSEMBLY	PART NUMBER	DESCRIPTION
0084	00001.000	0411115-0064	NUT, PLAIN 6-32 UNC-2B HEX CRES
0085	00001.000	J999924-0001	SWITCH GUARD
0086	00003.000	0418212-0040	STRAP, TIEDOWN, ADJUSTABLE, PLASTIC
0087	00001.000	0999737-8001	BASE ASSEMBLY, 820

LIST OF MATERIALS

DATE 07-12-79
P/N 0999690

820 Terminal, Basic - 115 V, 10CPI

0102
REV R

PRINT ITEM NUMBER	QUANTITY PER ASSEMBLY	PART NUMBER	DESCRIPTION
0002	00001.000	0999739-0001	COVER, PAPER CHUTE
0005	00004.000	0999885-0001	SHOCK MOUNT
0006	00001.000	0999689-0002	MECHANISM, 10 & 16.5 CPI
0007	00001.000	0999740-0001	NUTPLATE,HINGE-LEFT TERMINAL BASE
0008	00002.000	0999741-0001	HINGE, TERMINAL COVER
0012	00001.000	0999819-0001	FAN ASSEMBLY
0013	00001.000	0999720-0001	PLENUM, FAN
0014	00001.000	0983863-0001	BRACKET,FAN MOTOR
0016	00001.000	0999835-0001	CABLE ASSY, POWER DISTRIBUTION
0017	00001.000	0999743-0001	PANEL, EIA CABLE
0018	00001.000	0999742-0001	CABLE ASSEMBLY, EIA (INTERNAL)
0019	00001.000	0999781-0001	COVER, EIA CABLE PANEL
0020	00002.000	0808129-0001	CONNECTOR,ELECT SCREW-LOCK ASSY FEMALE
0023	00001.000	0999820-0101	TERMINAL ELECTRONICS w/GND PLANE-115V
0026	00001.000	0999744-0001	CARD FRAME, KEYBOARD/OPTION
0027	00004.000	0999745-0001	KEEPER, CARD FRAME
0029	00001.000	0999903-0001	KIT,EMULATOR-DECKEMENTER
0030	00001.000	0996774-0002	CABLE,ELEC,8.50LG FLAT,FLEXIBLE
0034	00001.000	0999749-0001	STAY, EXTERNAL
0035	00001.000	0999750-0001	STAY, INTERNAL
0038	00001.000	0999918-0001	COVER ASSY
0043	00002.000	0999762-0001	COVER, FALSE-ASR TERMINAL
0051	00001.000	0999833-0001	IDENTIFICATION KIT
0054	00002.000	0972734-0001	TERMINAL,ELECTRICAL,TAB-.250 INCH
0056	00002.000	0411115-0044	NUT,4-40 HEXAGON CRES STEEL
0057	00001.000	0411115-0084	NUT,PLAIN 8-32 UNC-2B HEX CRES
0060	00004.000	0972988-0014	SCREW 4-40 X .312 PAN HEAD CRES
0061	00013.000	0972988-0016	SCREW 4-40 X .438 PAN HEAD CRES
0062	00001.000	0972988-0018	SCREW 4-40 X .625 PAN HEAD CRES
0063	00004.000	2210071-0024	SCREW,8-32 X 1" MACHINE,HEX HEAD
0065	00001.000	0411101-0059	LOCKWASHER # 8 EXTERNAL TOOTH CRES
0066	00004.000	0416622-0024	WASHER #8 FLAT
0068	00018.000	0411104-0135	WASHER, LOCK-SPRING, HELICAL, #4
0070	00016.000	0416622-0011	WASHER #4 FLAT
0074	00001.000	0999792-0001	NUTPLATE,HINGE-RH TERMINAL BASE
0076	00002.000	0999793-0001	NUTPLATE,HINGE- TERMINAL COVER
0078	REF	0999833-9901	INTERCONNECTION DIAG 820 KSR
0081	00001.000	0999927-0001	GROUND STRAP MECHANISM
0082	00001.000	0972988-0027	SCREW 6-32 X .312 PAN HEAD CRES
0083	00002.000	0411101-0058	LOCKWASHER #6 EXTERNAL TOOTH CRES

LIST OF MATERIALS

DATE 07-12-79
P/N 0999690

820 Terminal, Basic - 115 V, 10CPI

0102
REV R

PRINT ITEM NUMBER	QUANTITY PER ASSEMBLY	PART NUMBER	DESCRIPTION
0084	00001.000	0411115-0064	NUT, PLAIN 6-32 UNC-2B HEX CRES
0085	00001.000	0999924-0001	SWITCH GUARD
0086	00003.000	0418212-0040	STRAP, TIEDOWN, ADJUSTABLE, PLASTIC
0087	00001.000	0999737-8001	BASE ASSEMBLY, 820

LIST OF MATERIALS

DATE 07-12-79
P/N 0999690

820 Terminal, Basic - 220, 10/16 CPI

0201
REV R

PRINT ITEM NUMBER	QUANTITY PER ASSEMBLY	PART NUMBER	DESCRIPTION
0002	00001.000	J999739-0001	COVER, PAPER CHUTE
0005	00004.000	J999885-0001	SHOCK MOUNT
0006	00001.000	J999689-0001	MECHANISM, 10 CPI
0007	00001.000	J999740-0001	NUTPLATE, HINGE-LEFT TERMINAL BASE
0008	00002.000	J999741-0001	HINGE, TERMINAL COVER
0012	00001.000	J999819-0001	FAN ASSEMBLY
0013	00001.000	J999720-0001	PLENUM, FAN
0014	00001.000	0983863-0001	BRACKET, FAN MOTOR
0016	00001.000	J999835-0001	CABLE ASSY, POWER DISTRIBUTION
0017	00001.000	J999743-0001	PANEL, EIA CABLE
0018	00001.000	J999742-0001	CABLE ASSEMBLY, EIA (INTERNAL)
0019	00001.000	J999781-0001	COVER, EIA CABLE PANEL
0020	00002.000	0808129-0001	CONNECTOR, ELECT SCREW-LOCK ASSY FEMALE
0023	00001.000	J999820-0201	TERMINAL ELECTRONICS W/GND PLANE-230V
0026	00001.000	J999744-0001	CARD FRAME, KEYBOARD/OPTION
0027	00004.000	J999745-0001	KEEPER, CARD FRAME
0029	00001.000	J999903-0001	KIT, EMULATOR-DECREMENTER
0030	00001.000	J996774-0002	CABLE, ELEC, 8.50LG FLAT, FLEXIBLE
0034	00001.000	J999749-0001	STAY, EXTERNAL
0035	00001.000	J999750-0001	STAY, INTERNAL
0038	00001.000	J999918-0001	COVER ASSY
0043	00002.000	J999762-0001	COVER, FALSE-ASR TERMINAL
0051	00001.000	J999833-0001	IDENTIFICATION KIT
0054	00002.000	J972734-0001	TERMINAL, ELECTRICAL, TAB-.250 INCH
0056	00002.000	0411115-0044	NUT, 4-40 HEXAGON CRES STEEL
0057	00001.000	0411115-0084	NUT, PLAIN 8-32 UNC-2B HEX CRES
0060	00004.000	0972988-0014	SCREW 4-40 X .312 PAN HEAD CRES
0061	00013.000	0972988-0016	SCREW 4-40 X .438 PAN HEAD CRES
0062	00001.000	0972988-0018	SCREW 4-40 X .625 PAN HEAD CRES
0063	00004.000	2210071-0024	SCREW, 8-32 X 1" MACHINE, HEX HEAD
0065	00001.000	0411101-0059	LOCKWASHER # 8 EXTERNAL TOOTH CRES
0066	00004.000	0416622-0024	WASHER #8 FLAT
0068	00018.000	0411104-0135	WASHER, LOCK-SPRING, HELICAL, #4
0070	00016.000	0416622-0011	WASHER #4 FLAT
0074	00001.000	J999792-0001	NUTPLATE, HINGE-RH TERMINAL BASE
0076	00002.000	J999793-0001	NUTPLATE, HINGE- TERMINAL COVER
0078	REF	J999833-9901	INTERCONNECTION DIAG 820 KSR
0081	00001.000	J999927-0001	GROUND STRAP MECHANISM
0082	00001.000	J972988-0027	SCREW 6-32 X .312 PAN HEAD CRES
0083	00002.000	0411101-0058	LOCKWASHER #6 EXTERNAL TOOTH CRES

LIST OF MATERIALS

DATE 07-12-79
P/N 0999690

820 Terminal, Basic - 220, 10/16 CPI

0201
REV R

PRINT ITEM NUMBER	QUANTITY PER ASSEMBLY	PART NUMBER	DESCRIPTION
0084	00001.000	0411115-0064	NUT, PLAIN 6-32 UNC-2B HEX CRES
0085	00001.000	0999924-0001	SWITCH GUARD
0086	00003.000	0418212-0040	STRAP, TIEDOWN, ADJUSTABLE, PLASTIC
0087	00001.000	0999737-8001	BASE ASSEMBLY, 820

LIST OF MATERIALS

DATE 07-12-79
P/N 0999690

820 Terminal, Basic - 220, 10/16 CPI

0202
REV R

PRINT ITEM NUMBER	QUANTITY PER ASSEMBLY	PART NUMBER	DESCRIPTION
0002	00001.000	J999739-0001	COVER, PAPER CHUTE
0005	00004.000	J999885-0001	SHOCK MOUNT
0006	00001.000	J999689-0002	MECHANISM, 10 & 16.5 CPI
0007	00001.000	J999740-0001	NUTPLATE, HINGE-LEFT TERMINAL BASE
0008	00002.000	J999741-0001	HINGE, TERMINAL COVER
0012	00001.000	J999819-0001	FAN ASSEMBLY
0013	00001.000	J999720-0001	PLENUM, FAN
0014	00001.000	J983863-0001	BRACKET, FAN MOTOR
0016	00001.000	J999835-0001	CABLE ASSY, POWER DISTRIBUTION
0017	00001.000	J999743-0001	PANEL, EIA CABLE
0018	00001.000	J999742-0001	CABLE ASSEMBLY, EIA (INTERNAL)
0019	00001.000	J999781-0001	COVER, EIA CABLE PANEL
0020	00002.000	J808129-0001	CONNECTOR, ELECT SCREW-LOCK ASSY FEMALE
0023	00001.000	J999820-0201	TERMINAL ELECTRONICS W/GND PLANE-230V
0026	00001.000	J999744-0001	CARD FRAME, KEYBOARD/OPTION
0027	00004.000	J999745-0001	KEEPER, CARD FRAME
0029	00001.000	J999903-0001	KIT, EMULATOR-DECREMENTER
0030	00001.000	J996774-0002	CABLE, ELEC, 8.50LG FLAT, FLEXIBLE
0034	00001.000	J999749-0001	STAY, EXTERNAL
0035	00001.000	J999750-0001	STAY, INTERNAL
0038	00001.000	J999918-0001	COVER ASSY
0043	00002.000	J999762-0001	COVER, FALSE-ASK TERMINAL
0051	00001.000	J999833-0001	IDENTIFICATION KIT
0054	00002.000	J972734-0001	TERMINAL, ELECTRICAL, TAB-.250 INCH
0056	00002.000	J411115-0044	NUT, 4-40 HEXAGON CRES STEEL
0057	00001.000	J411115-0084	NUT, PLAIN 8-32 UNC-2B HEX CRES
0060	00004.000	J972988-0014	SCREW 4-40 X .312 PAN HEAD CRES
0061	00013.000	J972988-0016	SCREW 4-40 X .438 PAN HEAD CRES
0062	00001.000	J972988-0019	SCREW 4-40 X .750 PAN HEAD CRES
0063	00004.000	2210071-0024	SCREW, 8-32 X 1" MACHINE, HEX HEAD
0065	00001.000	J411101-0059	LOCKWASHER # 8 EXTERNAL TOOTH CRES
0066	00004.000	J416622-0024	WASHER #8 FLAT
0068	00018.000	J411104-0135	WASHER, LOCK-SPRING, HELICAL, #4
0070	00016.000	J416622-0011	WASHER #4 FLAT
0074	00001.000	J999792-0001	NUTPLATE, HINGE-RH TERMINAL BASE
0076	00002.000	J999793-0001	NUTPLATE, HINGE- TERMINAL COVER
0078	REF	J999833-9901	INTERCONNECTION DIAG 820 KSR
0081	00001.000	J999927-0001	GROUND STRAP MECHANISM
0082	00001.000	J972988-0027	SCREW 6-32 X .312 PAN HEAD CRES
0083	00002.000	J411101-0058	LOCKWASHER #6 EXTERNAL TOOTH CRES

LIST OF MATERIALS

DATE 07-12-79
P/N 0999690

820 Terminal, Basic - 220, 10/16 CPI

0202
REV R

PRINT ITEM NUMBER	QUANTITY PER ASSEMBLY	PART NUMBER	DESCRIPTION
0084	00001.000	0411115-0064	NUT, PLAIN 6-32 UNC-2B HEX CRES
0085	00001.000	0999924-0001	SWITCH GUARD
0086	00003.000	0418212-0040	STRAP, TIEDOWN, ADJUSTABLE, PLASTIC
0087	00001.000	0999737-8001	BASE ASSEMBLY, 820

LIST OF MATERIALS

DATE 07-12-79
P/N 0999690

820 Terminal, Basic - 220, 10/16 CPI (BPD)

0401
REV R

PRINT ITEM NUMBER	QUANTITY PER ASSEMBLY	PART NUMBER	DESCRIPTION
0002	00001.000	0999739-0001	COVER, PAPER CHUTE
0005	00004.000	0999885-0001	SHOCK MOUNT
0006	00001.000	0999689-0001	MECHANISM, 10 CPI
0007	00001.000	0999740-0001	NUTPLATE,HINGE-LEFT TERMINAL BASE
0008	00002.000	0999741-0001	HINGE, TERMINAL COVER
0012	00001.000	0999819-0001	FAN ASSEMBLY
0013	00001.000	0999720-0001	PLENUM, FAN
0014	00001.000	0983863-0001	BRACKET,FAN MOTOR
0016	00001.000	0999835-0002	CABLE ASSY,POWER DISTRIBUTION (BPD)
0017	00001.000	0999743-0001	PANEL, EIA CABLE
0018	00001.000	0999742-0001	CABLE ASSEMBLY, EIA (INTERNAL)
0019	00001.000	0999781-0001	COVER, EIA CABLE PANEL
0020	00002.000	0808129-0001	CONNECTOR,ELECT SCREW-LOCK ASSY FEMALE
0023	00001.000	0999820-0401	TERM ELECTRONICS W/GND PLANE-230V BPD
0026	00001.000	0999744-0001	CARD FRAME, KEYBOARD/OPTION
0027	00004.000	0999745-0001	KEEPER, CARD FRAME
0029	00001.000	0999903-0001	KIT,EMULATOF-DECREMENTER
0030	00001.000	0996774-0002	CABLE,ELEC,8.50LG FLAT,FLEXIBLE
0034	00001.000	0999749-0001	STAY, EXTERNAL
0035	00001.000	0999750-0001	STAY, INTERNAL
0038	00001.000	0999918-0001	COVER ASSY
0043	00002.000	0999762-0001	COVER, FALSE-ASR TERMINAL
0051	00001.000	0999833-0001	IDENTIFICATION KIT
0054	00002.000	0972734-0001	TERMINAL,ELECTRICAL,TAG-.250 INCH
0056	00002.000	0411115-0044	NUT,4-40 HEXAGON CRES STEEL
0057	00001.000	0411115-0084	NUT,PLAIN 8-32 UNC-2B HEX CRES
0060	00004.000	0972988-0014	SCREW 4-40 X .312 PAN HEAD CRES
0061	00013.000	0972988-0016	SCREW 4-40 X .438 PAN HEAD CRES
0062	00001.000	0972988-0018	SCREW 4-40 X .625 PAN HEAD CRES
0063	00004.000	2210071-0024	SCREW,8-32 X 1" MACHINE,HEX HEAD
0065	00001.000	0411101-0059	LOCKWASHER # 8 EXTERNAL TOOTH CRES
0066	00004.000	0416622-0024	WASHER #8 FLAT
0068	00018.000	0411104-0135	WASHER, LOCK-SPRING, HELICAL, #4
0070	00016.000	0416622-0011	WASHER #4 FLAT
0074	00001.000	0999792-0001	NUTPLATE,HINGE-RH TERMINAL BASE
0076	00002.000	0999793-0001	NUTPLATE,HINGE- TERMINAL COVER
0078	REF	0999833-9901	INTERCONNECTION DIAG 820 KSR
0081	00001.000	0999927-0001	GROUND STRAP MECHANISM
0082	00001.000	0972988-0027	SCREW 6-32 X .312 PAN HEAD CRES
0083	00002.000	0411101-0058	LOCKWASHER #6 EXTERNAL TOOTH CRES

LIST OF MATERIALS

DATE 07-12-79
P/N 0999690

820 Terminal, Basic - 220, 10/16 CPI (BPD)

REV 0401
R

PRINT ITEM NUMBER	QUANTITY PER ASSEMBLY	PART NUMBER	DESCRIPTION
0084	00001.000	0411115-0064	NUT, PLAIN 6-32 UNC-2B HEX CKES
0085	00001.000	0999924-0001	SWITCH GUARD
0086	00003.000	0418212-0040	STRAP, TIEDOWN, ADJUSTABLE, PLASTIC
0087	00001.000	0999737-8001	BASE ASSEMBLY, 820

LIST OF MATERIALS

DATE 07-12-79
P/N 0999690

820 Terminal, Basic - 220, 10/16 CPI (BPD)

0402
REV R

PRINT ITEM NUMBER	QUANTITY PER ASSEMBLY	PART NUMBER	DESCRIPTION
0002	0001.000	0999739-0001	COVER, PAPER CHUTE
0005	00004.000	0999885-0001	SHOCK MOUNT
0006	00001.000	0999689-0002	MECHANISM, 10 & 16.5 CPI
0007	00001.000	0999740-0001	NUTPLATE,HINGE-LEFT TERMINAL BASE
0008	00002.000	0999741-0001	HINGE, TERMINAL COVER
0012	00001.000	0999819-0001	FAN ASSEMBLY
0013	00001.000	0999720-0001	PLENUM, FAN
0014	00001.000	0983863-0001	BRACKET,FAN MOTOR
0016	00001.000	0999835-0002	CABLE ASSY,POWER DISTRIBUTION (BPD)
0017	00001.000	0999743-0001	PANEL, EIA CABLE
0018	00001.000	0999742-0001	CABLE ASSEMBLY, EIA (INTERNAL)
0019	00001.000	0999781-0001	COVER, EIA CABLE PANEL
0020	00002.000	0808129-0001	CONNECTOR,ELECT SCREW-LOCK ASSY FEMALE
0023	00001.000	0999820-0401	TERM ELECTRONICS W/GND PLANE-230V BPD
0026	00001.000	0999744-0001	CARD FRAME, KEYBOARD/OPTION
0027	00004.000	0999745-0001	KEEPER, CARD FRAME
0029	00001.000	0999903-0001	KIT,EMULATOR-DECREMENTER
0030	00001.000	0996774-0002	CABLE,ELEC,8.50LG FLAT,FLEXIBLE
0034	00001.000	0999749-0001	STAY, EXTERNAL
0035	00001.000	0999750-0001	STAY, INTERNAL
0038	00001.000	0999918-0001	COVER ASSY
0043	00002.000	0999762-0001	COVER, FALSE-ASK TERMINAL
0051	00001.000	0999833-0001	IDENTIFICATION KIT
0054	00002.000	0972734-0001	TERMINAL,ELECTRICAL,TAB-.250 INCH
0056	00002.000	0411115-0044	NUT,4-40 HEXAGON CRES STEEL
0057	00001.000	0411115-0084	NUT,PLAIN 8-32 UNC-2B HEX CRES
0060	00004.000	0972988-0014	SCREW 4-40 X .312 PAN HEAD CRES
0061	00013.000	0972988-0016	SCREW 4-40 X .438 PAN HEAD CRES
0062	00001.000	0972988-0019	SCREW 4-40 X .750 PAN HEAD CRES
0063	00004.000	2210071-0024	SCREW,8-32 X 1" MACHINE,HEX HEAD
0065	00001.000	0411101-0059	LOCKWASHER # 8 EXTERNAL TOOTH CRES
0066	00004.000	0416622-0024	WASHER #8 FLAT
0068	00018.000	0411104-0135	WASHER, LOCK-SPRING, HELICAL, #4
0070	00016.000	0416622-0011	WASHER #4 FLAT
0074	00001.000	0999792-0001	NUTPLATE,HINGE-RH TERMINAL BASE
0076	00002.000	0999793-0001	NUTPLATE,HINGE- TERMINAL COVER
0078	REF	0999833-9901	INTERCONNECTION DIAG 820 KSR
0081	00001.000	0999927-0001	GROUND STRAP MECHANISM
0082	00001.000	0972988-0027	SCREW 6-32 X .312 PAN HEAD CRES
0083	00002.000	0411101-0058	LOCKWASHER #6 EXTERNAL TOOTH CRES

LIST OF MATERIALS

DATE 07-12-79
P/N 0999690

820 Terminal, Basic - 220, 10/16 CPI (BPD)

0402
REV R

PRINT ITEM NUMBER	QUANTITY PER ASSEMBLY	PART NUMBER	DESCRIPTION
0084	00001.000	0411115-0064	NUT, PLAIN 6-32 UNC-2B HEX CRES
0085	00001.000	0999924-0001	SWITCH GUARD
0086	00003.000	0418212-0040	STRAP, TIEDOWN, ADJUSTABLE, PLASTIC
0087	00001.000	0999737-8001	BASE ASSEMBLY, 820

8

7

6

5

4

3

DWG NO 999691 2

1

D

D

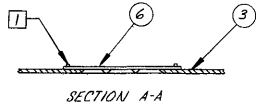

2

1

5

C

C

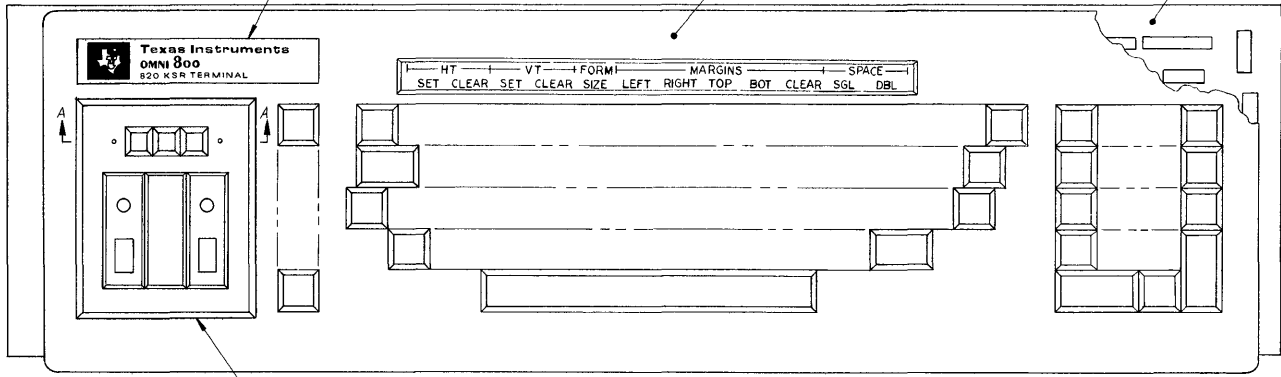

Texas Instruments
OMNI 800
820 KSR TERMINAL

HT	VT	FORM	MARGINS	SPACE
SET	CLEAR	SET	CLEAR	SIZE
LEFT	RIGHT	TOP	BOT	CLEAR
SGL	DBL			

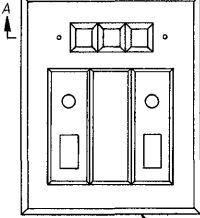

3

- 0102

B

B

A

A

6-49

8

7

6

5

4

3

2

1

TEXAS INSTRUMENTS CORPORATION DALLAS, TEXAS	DATE	12 16 77	DWG NO	D 96214	DRAWING NO	999691	REV	FLM C
	ISSUE DATE		SCALE	1/1	SHEET	2		

LIST OF MATERIALS

DATE 6-29-79
P/N 999691

Keyboard Assy, Full ASCII

000 0101
REV D

PRINT ITEM NUMBER	QUANTITY PER ASSEMBLY	PART NUMBER	DESCRIPTION
0001	00001.000	0999766-0001	BEZFL, KEYBOARD
0002	00001.000	0999758-0001	NAMEPLATF, 820 TERMINAL
0003	00001.000	0999767-0002	PLATE, KEYBOARD, US ASCII
0004	00001.000	0999767-0001	PLATE, KEYBOARD, BLANK
0005	00001.000	0999712-0101	KYBD, 820 KSR- STD ASCII
0006	00001.000	0999733-0001	FILTER, KEYBOARD PLATE
0007	00000.000	0999864-0101	KYBD, UNENCODED USASCII
0007A			THIS ITEM MAY BE
0007B			SUBSTITUTED FOR ITEM 5.
0007C			IT IS TO BE USED ON ALL
0007D			INT'L CHARACTER SETS

DATE 6-29-79
P/N 999961

Keyboard Assy, Full ASCII

000 0102
REV D

0001	00001.000	0999766-0001	BEZEL, KEYBOARD
0002	00001.000	0999758-0001	NAMEPLATE, 820 TERMINAL
0003	00001.000	0999767-0002	PLATE, KEYBOARD, US ASCII
0005	00001.000	0999712-0102	KYBD, 820 KSR, STD. ASCII, W/NUM CLST OPTION
0006	00001.000	0999733-0001	FILTER, KEYBOARD PLATE
0007	00000.000	0999864-0102	KYBD, UNENCODED, W/NUM KEYPAD, USASCII
0007A			THIS ITEM MAY BE
0007B			SUBSTITUTED FOR ITEM 5.
0007C			IT IS TO BE USED ON ALL
0007D			INT'L CHARACTER SETS

LIST OF MATERIALS

DATE 06-29-79
P/N 999691

Keyboard Assy, APL

000 0201
REV D

PRINT ITEM NUMBER	QUANTITY PER ASSEMBLY	PART NUMBER	DESCRIPTION
0001	00001.000	0999766-0001	BEZEL, KEYBOARD
0002	00001.000	0999758-0001	NAMEPLATE, 820 TERMINAL
0003	00001.000	0999767-0004	PLATE, KEYBOARD, APL
0004	00001.000	0999767-0001	PLATE, KEYBOARD, BLANK
0005	00001.000	0999868-0201	KYBD, UNENCODED, APL
0006	00001.000	0999733-0001	FILTER, KEYBOARD PLATE

DATE 06-29-79
P/N 999691

Keyboard Assy, APL

000 0202
REV D

0001	00001.000	0999766-0001	BEZEL, KEYBOARD
0002	00001.000	0999758-0001	NAMEPLATE, 820 TERMINAL
0003	00001.000	0999767-0004	PLATE, KEYBOARD, APL
0005	00001.000	0999868-0202	KYBD, UNENCODED, W/NUM KEYPAD, APL
0006	00001.000	0999733-0001	FILTER, KEYBOARD PLATE

LIST OF MATERIALS

DATE 06-29-79
P/N 999691

Keyboard Assy, APL

000 8201
REV D

PRINT ITEM NUMBER	QUANTITY PER ASSEMBLY	PART NUMBER	DESCRIPTION
0001	00001.000	0999691-0201	KIT, KYBD ASSY, APL

DATE 06-29-79
P/N 999691

Keyboard Assy, APL

000 8202
REV D

0001	00001.000	0999691-0202	KIT, KYBD ASSY, W/NUM PAD
------	-----------	--------------	---------------------------

LIST OF MATERIALS

DATE 06-29-79
P/N 999691

Keyboard Assy, Full ASCII

000 8101
REV D

PRINT ITEM NUMBER	QUANTITY PER ASSEMBLY	PART NUMBER	DESCRIPTION
0001	00001.000	0999691-0101	KIT, KYBD ASSY, FULL ASCII

DATE 06-29-79
P/N 999691

000 8102
REV D

0001	00001.000	0999691-0102	KIT, KYBD ASSY, FULL ASCII W/NUMERIC PAD
------	-----------	--------------	--

8

7

6

5

4

3

999859

1

NOTES UNLESS OTHERWISE SPECIFIED
 1 INSTALL ITEM 6 TO ITEM 3 BY HEAT
 SWAGING POST-2 PLACES

REVISIONS			
REV	DESCRIPTION	DATE	APPROVED
A	CN445396 <i>Shi</i>	7-11-79	<i>[Signature]</i>
SHI 2A-1, TITLE WAS "KIT, KEYBOARD"			
FORMAL RELEASE			

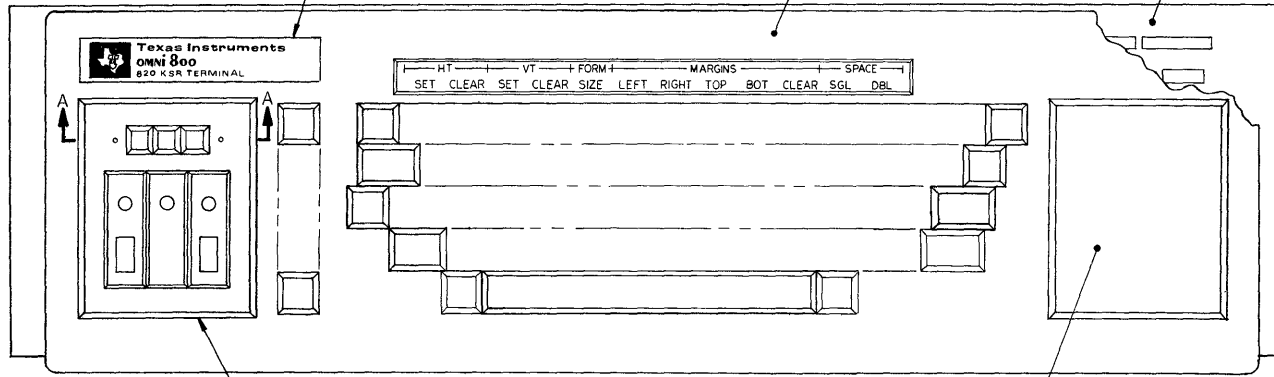
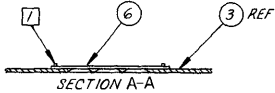

6-54

PART NUMBER	DESCRIPTION
999859-0001	KEYBOARD KIT, KATAKANA
999859-0002	KEYBOARD KIT, KATAKANA WITH NUMERIC PAD

REV STATUS OF SHEETS	REV	A	B	C	D
SH	1	2			

-0001

QTY	ITEM NO	PART OR IDENTIFYING NUMBER	NOMENCLATURE OR DESCRIPTION	PROCUREMENT SPECIFICATION	NOTES
			UNLESS OTHERWISE SPECIFIED * DIMENSIONS ARE IN INCHES * TOLERANCES - ANGLES ±1° 3 PLACE DECIMALS ± 0.01 2 PLACE DECIMALS ± 0.02 * INTERPRET DRAWING PER MIL-D-1000 * REMOVE ALL BURRS AND SHARP EDGES * CONCENTRICITY MACHINED DIAMETERS .010 F/M * DIMENSIONAL LIMITS APPLY BEFORE PROCESSES * PARENTHETICAL INFO FOR REF ONLY HOLE TOLERANCE THRU + .004 - .002 125 - .001 250 - .001 500 - .001 750 - .001 1000 - .002 2000 - .002		
999683	8740		DATE 5/11/79 BY <i>[Signature]</i> CHKD <i>[Signature]</i> 7/11/79 APPD <i>[Signature]</i> 7/12/79 DATE <i>[Signature]</i> 7/12/79 BY <i>[Signature]</i>	TEXAS INSTRUMENTS INCORPORATED DALLAS, TEXAS KEYBOARD KIT, KATAKANA	
			999859	999859	

SEQ NO	IDENT	F SPEC	NO	ADDITIONAL	NOTES

PROCESSES - FOR CORRELATION TO GOVT/IND SPECIFICATIONS SEE TI DRAWING 723467

8

7

6

5

4

30

3

2

LM

1

SHEET 1 OF 2

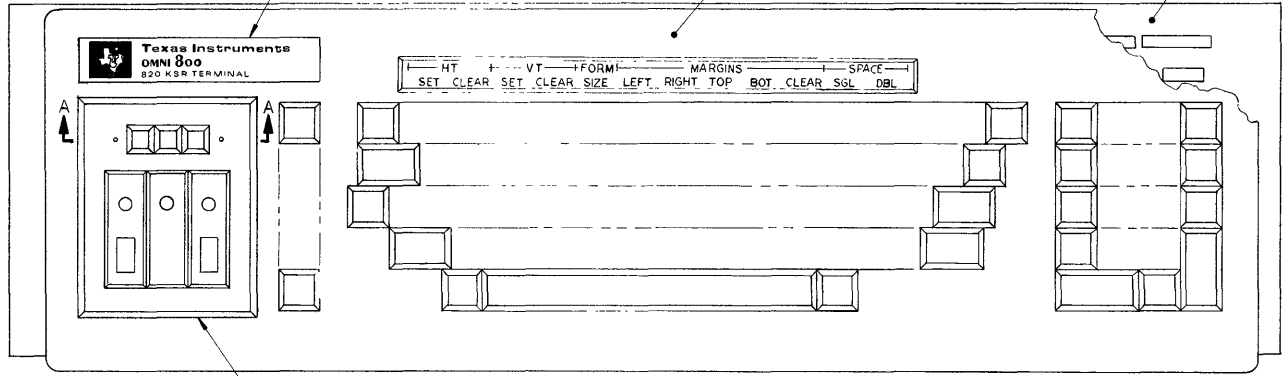
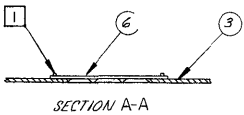

HT		VT		FORM		MARGINS			SPACE		
SET	CLEAR	SET	CLEAR	SIZE	LEFT	RIGHT	TOP	BOT.	CLEAR	SGL	DBL

-0002

6-55

LIST OF MATERIALS

DATE 06-28-79
P/N 0999859

Keyboard Kit, Katakana

000 1
REV A

PRINT ITEM NUMBER	QUANTITY PER ASSEMBLY	PART NUMBER	DESCRIPTION
0301	00001.000	2206571-0001	BEZEL, KEY BOARD, KATAKANA
0302	00001.000	0999758-0001	NAMEPLATE, 820 TERMINAL
0303	00001.000	0999767-0003	PLATE, KEYBOARD, KATAKANA
0304	00001.000	0999767-0001	PLATE, KEYBOARD, BLANK
0305	00001.000	2206572-0101	KEYBOARD, KATAKANA
0306	00001.000	0999733-0001	FILTER, KEYBOARD PLATE

DATE 06-28-79
P/N 0999859

000 2
REV A

0301	00001.000	2206571-0001	BEZEL, KEY BOARD, KATAKANA
0302	00001.000	0999758-0001	NAMEPLATE, 820 TERMINAL
0303	00001.000	0999767-0003	PLATE, KEYBOARD, KATAKANA
0305	00001.000	2206572-0102	KEYBOARD, KATAKANA
0306	00001.000	0999733-0001	FILTER, KEYBOARD PLATE

- NOTES UNLESS OTHERWISE SPECIFIED
- 1 TIGHTEN TO 16±1 IN-LB AFTER POSITIONING CARRIAGE
 - 2 TIGHTEN TO 13±1 FT-LB AFTER POSITIONING PLATEN (ITEM 3) AND BEFORE ASSEMBLING HOUSINGS (ITEM 34) TO SIDE PLATES (ITEMS 112)
 - 3 TIGHTEN TO 30±1 IN-LB AFTER POSITIONING SIDE PLATES

- 4 ADJUST SWITCH (ITEM 44) TO DIM SHOWN WHEN SWITCH LEVER (IN CLOSED POSITION) IS IN CONTACT WITH SWITCH CASE
- 5 WITH HEAD ADJUSTMENT LEVER (ITEM 10) IN INNERMOST POSITION, ADJUST PLATEN TO CARRIAGE HEAD MOUNTING SURFACE A DISTANCE OF 2.210±.002 OVER FULL TRAVEL OF CARRIAGE CHECK THAT PARALLELISM BETWEEN CARRIAGE TRAVEL AND PLATEN DOES NOT VARY MORE THAN .004 IN MIDDLE AND OUTERMOST POSITIONS OF HEAD ADJUST LEVER
- 6 TIGHTEN TO 4.5 ±.5 IN-LB

- 7 TIGHTEN SCREW (ITEM 67) 1/4 TO 1/2 TURN AFTER ZERO END PLAY IS ACHIEVED IN UPPER CARRIAGE ROD. CAUTION! OVERTIGHTENING (GREATER THAN 1/2 TURN PAST ZERO END PLAY) WILL DEFORM SIDE PLATE AND CREATE EXCESSIVE FRICTION IN HEAD ADJUST LEVER MOVEMENT
- 8 USE 10 TO 12 DROPS ON FELT AT EACH END
- 9 PAPER GUIDE (ITEM 4) SHALL BE ADJUSTED SO THAT THE ASSY SHALL MEET THE DIMENSION SHOWN

- 10 PHASING MARKS ON PAPER TRACTOR (ITEM 25) SHALL BE ALIGNED TO THE SAME CORNER OF DRIVE SHAFT (ITEM 28)
- 11 MARK ASSY NO, APPROPRIATE REV LETTER, SERIAL NO (SITE DATE CODE & SERIAL NO) PER ITEM 94 PARAGRAPH 3.0 AND MADE IN USA ON ITEM 93 LOCATED APPROXIMATELY AS SHOWN USING GOTHIC STYLE LETTERS PER PROCESS 1
- 12 ASSEMBLE PAPER RETAINER (ITEM 5) SO THAT ASSEMBLY MEETS DIMENSION SHOWN

NOTES CONT'D ON SH 2

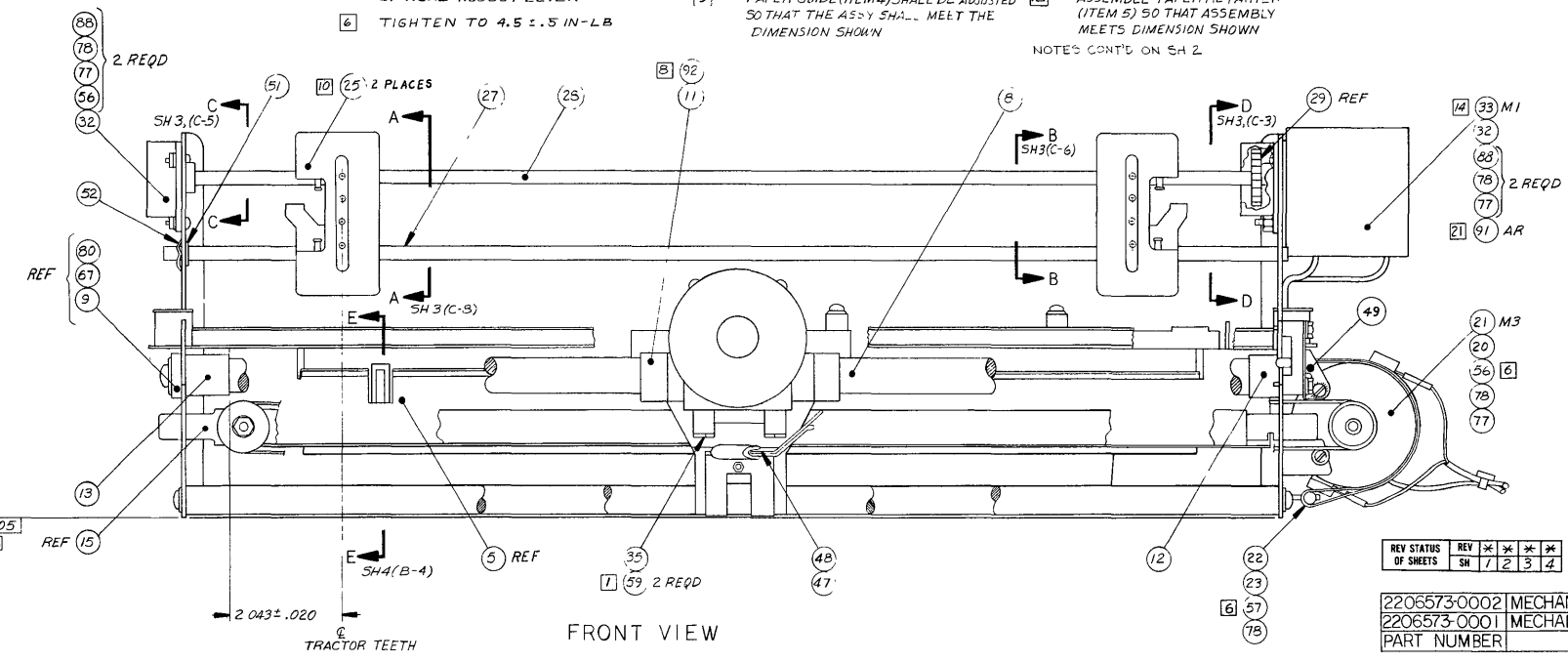

REV STATUS OF SHEETS	REV	BY	CHK	APP	DATE
	1	2	3	4	

2206573-0002	MECHANISM, IO & 16.5 CPI
2206573-0001	MECHANISM, IO
PART NUMBER	DESCRIPTION

6-57

1	MARK	100-00	00	HEIGHT .10 COLOR BLACK	17
SEQ NO	IDENT	F SPEC	NO	ADDITIONAL	NOTES
	PROCESS			CLASSIFICATION	

ITEM NO	QTY	PART OR IDENTIFYING NUMBER	NOMENCLATURE OR DESCRIPTION	PROCUREMENT SPECIFICATION	NOTES
UNLESS OTHERWISE SPECIFIED					
• DIMENSIONS ARE IN INCHES					
• TOLERANCES - ANGLES .1					
• 3 PLACE DECIMALS ±.010					
• 2 PLACE DECIMALS ±.02					
• INTERPRET DRAWING PER MIL D 1000					
• REMOVE ALL BURRS AND SHARP EDGES					
• CONCENTRICITY MACHINED DIAMETERS .010 FMM					
• DIMENSIONAL LIMITS APPLY BEFORE PROCESSES					
• PARENTHEICAL INFO FOR REF ONLY					
HOLE TOLERANCE					
.013	.004	.125	.005	.751	.006
.125	.001	.125	.001	.751	.002
.501	.008	.125	.010	1.001	.012
.750	.011	1.000	.031	2.000	.031
DATE: 7-15-79					
DRAWN BY: Dan Stamm 8-8-79					
CHECKED BY: Dan Stamm 8-8-79					
DATE: 8/6/79					
APPROVED BY: [Signature]					
DATE: 8/8/79					
PARTS LIST				TEXAS INSTRUMENTS INCORPORATED DALLAS, TEXAS	
999690 8740 NEXT ASSY USED ON APPLICATION				MECHANISM, 820 D 96214 2206573 SCALE 1/1 SHEET 1 OF 4	

- 13 APPLIES AT LOCATION DIRECTLY BELOW THE TWO BOTTOM SPACER MOUNTING HOLES
- 14 ORIENT MOTOR (ITEM 33) SO THAT MOTOR CABLE EXITS IN POSITION SHOWN
- 15 TIGHTEN TO 9±1IN-LB
- 16 CENTER RIBBON IN SLOTS ON EACH END OF SHIFT ARM SO THAT RIBBON DOES NOT TOUCH SIDES OF SLOTS BY ADJUSTING RIBBON DRIVE ASSY (ITEM 39)
- 17 TIGHTEN PRINTHEAD MOUNTING NUTS (ITEM 37) TO 5.0±.5 IN LB.(FINGERTIGHT PLUS ONE SIXTH (1/6) TURN APPROXIMATELY)
- 18 ROLLER (ITEM 45) SHALL BE ASSEMBLED TO HOUSING (ITEM 34) AND NOSEGUIDE (ITEM 38) WITH RIVETS (ITEM 46). AFTER ASSEMBLY, ROLLERS SHALL ROTATE FREELY ABOUT RIVETS.
- 19 NOSEGUIDE (ITEM 38) SHALL BE ASSEMBLED PER DIM SHOWN IN SECTION K-K
- 20 APPLY LUBRICANT (ITEM 91) TO SUPPORT (ITEM 15) WHERE RETAINER (ITEM 5) PASSES THRU LEFT SIDE PLATE (ITEM 2 ONLY)
- 21 APPLY LUBRICANT (ITEM 91) BETWEEN RIVET ON GEAR (ITEM 29) AND MOTOR ASSY (ITEM 33)
- 22 AFTER ASSY IT IS PERMISSIBLE FOR BUMPER TO TOUCH SIDE PLATE PLANE

85-9

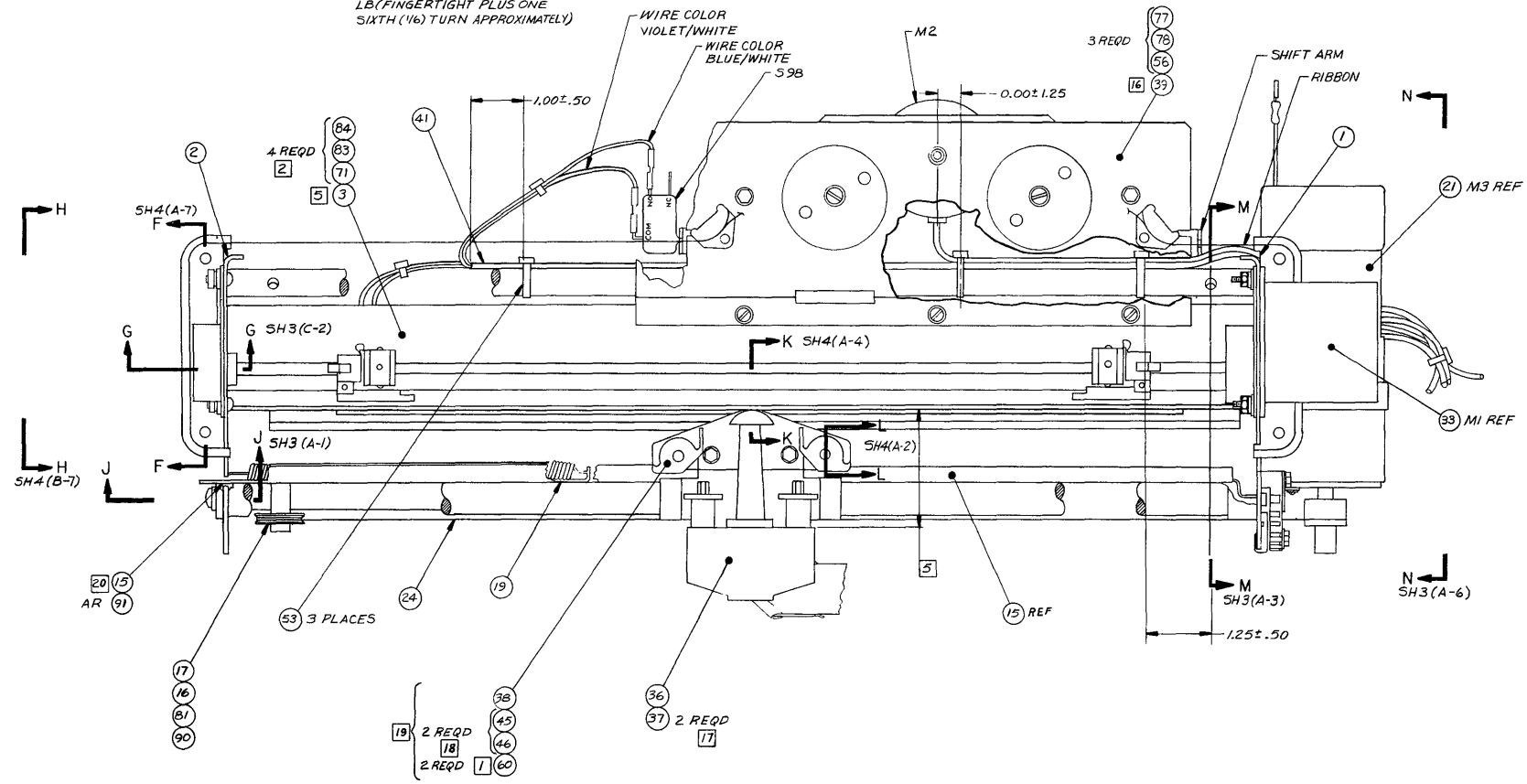

TOP VIEW

TEXAS INSTRUMENTS CORPORATION	DATE 7-12-79	SIZE FROM NO D96214	DRAWING NO 2206573	REV
ISSUE DATE	SCALE 1/1	SHEET 2	FILED	

8 7 6 5 4 3 2 1

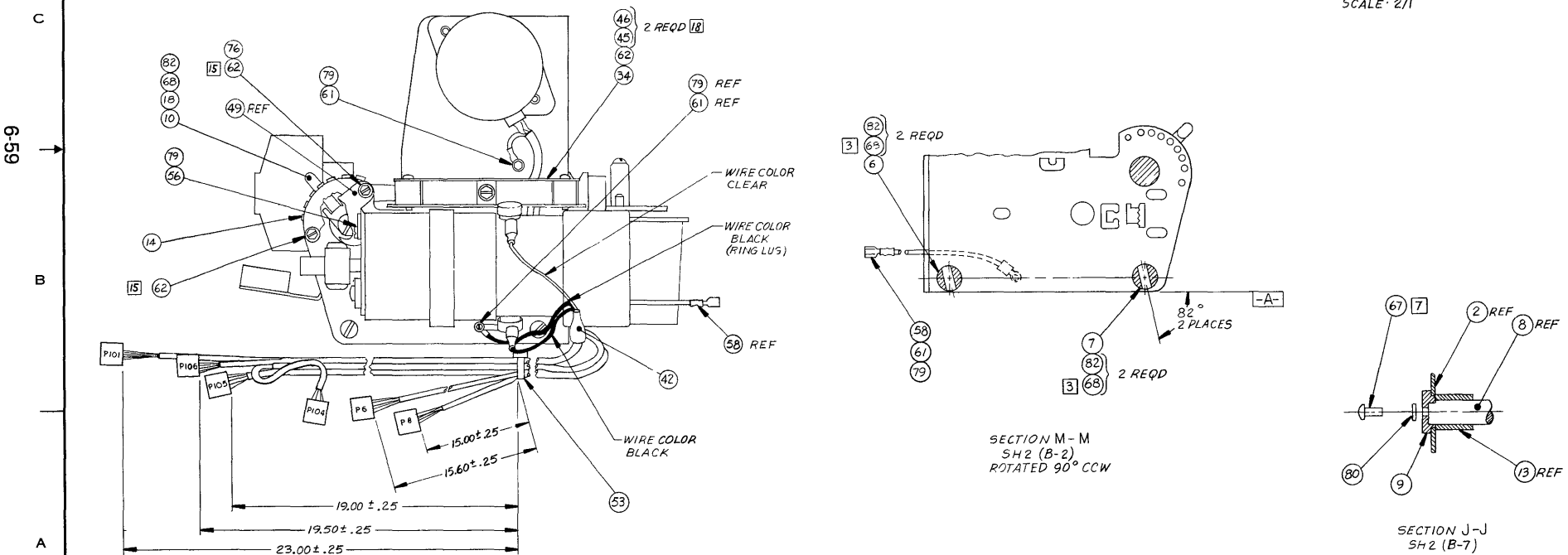
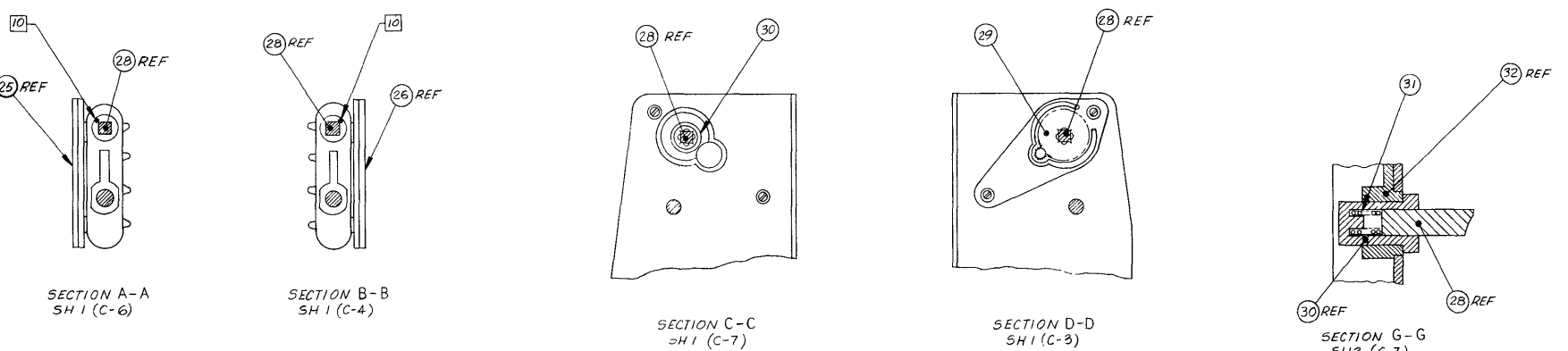

65-59

D
C
B
A

D
C
B
A

8 7 6 5 4 3 2 1

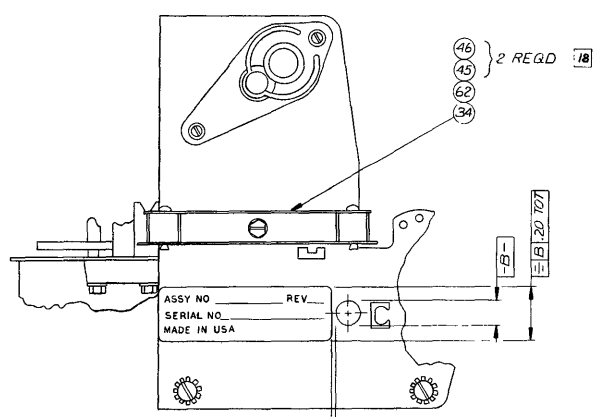

VIEW H-H
SH 2 (B-8)
ROTATED 90° CCW

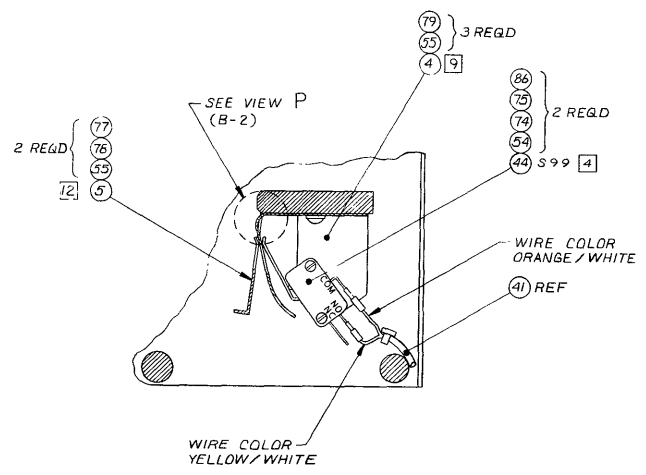

SECTION E-E
SH 1 (B-7)

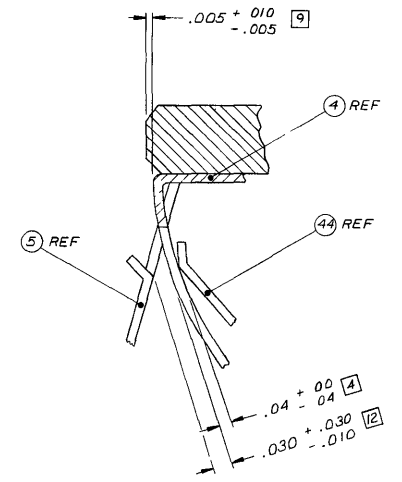

VIEW P
(D-4)
SCALE: NONE



SECTION F-F
SH 2 (C-7)
SCALE: 2/1
ROTATED 90° CW
2 PLACES
(1 OPP HAND)

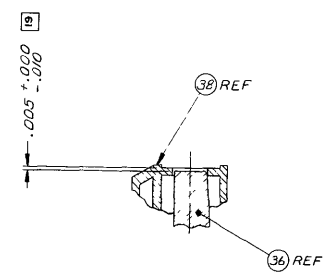

SECTION K-K
SH 2 (C-4)
SCALE: 2/1

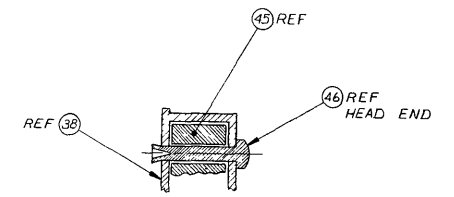

SECTION L-L
SH 2 (B-4)
SCALE: 2/1
2 PLACES

09-9

LIST OF MATERIALS

DATE: 08-06-79
P/N 2206573

Mechanism, 10/16 CPI

000 1
REV *

PRINT ITEM NUMBER	QUANTITY PER ASSEMBLY	PART NUMBER	DESCRIPTION
0001	00001.000	0999715-0001	SIDE PLATE,DRIVE MECHANISM-RIGHT SIDE
0002	00001.000	0999715-0002	SIDE PLATE,DRIVE MECHANISM-LEFT SIDE
0003	00001.000	0999724-0001	PLATEN, 820 TERMINAL
0004	00001.000	0994210-0001	PAPER GUIDE,PLATEN
0005	00001.000	0999725-0001	RETAINER, PAPER-PLATEN
0006	00001.000	0994186-0002	SPACER,LOWER REAR .250 HOLE DIA 820CPNTR
0007	00001.000	0999705-0001	ROD,GUIDE-LOWER
0008	00001.000	0994490-0001	GUIDE ROD, UPPER
0009	00001.000	0994197-0001	BUSHING,GUIDE ROD
0010	00001.000	0999726-0001	LEVER, ADJUSTMENT- PRINTHEAD
0011	00001.000	0999913-0001	CARRIAGE ASSY, PRINTHEAD
0012	00001.000	0999727-0001	BUMPER,CARRIAGE-RIGHT
0013	00001.000	0999727-0002	BUMPER,CARRIAGE-LEFT
0014	00001.000	0994232-0001	SCALE,HEAD GAP
0015	00001.000	0994194-0001	SUPPORT, IDLER PULLEY
0016	00001.000	0994195-0001	SPACER, IDLER PULLEY
0017	00001.000	0994241-0001	PULLEY ASSY, IDLER
0018	00001.000	0994454-0001	SPRING,GROUNDING
0019	00001.000	0994263-0001	SPRING,TENSION WIRE ROPE
0020	00001.000	0999703-0001	CRADLE, MOTOR
0021	00001.000	0994238-0003	CARRIAGE DRIVE MOTOR ASSY-10 CPI (820)
0021A			M3
0022	00001.000	0994201-0001	STRAP,MOTOR
0023	00001.000	0994202-0001	NUT,MOTOR STRAP
0024	00001.000	0994233-0001	WIRE ROPE,DRIVE MECHANISM
0025	00001.000	0996158-0003	TRACTOR,PAPER,PREC. PR RT & LF HAND
0027	00001.000	0994209-0001	ROD,TRACTOR SUPPORT
0028	00001.000	0994172-0001	DRIVE SHAFT,TRACTOR
0029	00001.000	0999780-0001	GEAR ASSY, PAPER ADVANCE
0030	00001.000	0994173-0001	HUB,PAPER ADVANCE
0031	00001.000	0994302-0001	SPRING,COMPRESSION-PAPER DRIVE SHAFT
0032	00002.000	0999729-0001	BEARING, PAPER ADVANCE
0033	00001.000	0999829-0001	MOTOR ASSEMBLY, PAPER DRIVE
0033A			M1
0034	00002.000	0999731-0001	HOUSING,RIBBON GUIDE-SIDE PLATE
0035	00001.000	0999704-0001	CLAMP, WIRE ROPE
0036	00001.000	0999732-0001	PRINTHEAD ASSEMBLY,30VCLT
0037	00002.000	0994199-0001	NUT,PRINTHEAD

LIST OF MATERIALS

DATE: 08-06-79
P/N: 2206573

Mechanism, 10/16 CPI

000 1
REV *

PRINT ITEM NUMBER	QUANTITY PER ASSEMBLY	PART NUMBER	DESCRIPTION
0038	00001.000	0999698-0001	NOSEGUIDE, PRINTHEAD
0039	00001.000	0999687-0001	RIBBON DRIVE
0041	00001.000	0999735-0001	CABLE ASSY, PAPER OUT
0042	00001.000	0999736-0001	CABLE ASSY, CARRIAGE DRIVE
0044	00001.000	0996169-0001	SWITCH, SENSITIVE
0044A			S99
0045	00006.000	0999697-0001	ROLLER, RIBBON
0046	00006.000	0411059-0169	RIVET-TUBULAR, .680LG, .123NCM SZ, OVAL HD
0047	00001.000	0983903-0002	CLIP, CABLE
0048	00001.000	0999791-0001	CABLE ASSY, PRINTHEAD
0049	00001.000	0999928-0001	GROUND STRAP, CARRIAGE MOTOR
0051	00001.000	0416402-4031	RING, RETAINING, EXTERNAL "E"
0052	00001.000	0411778-0005	RING, RETAINING, EXTERNAL BOWED
0053	00004.000	0418212-0040	STRAP, TIEDOWN, ADJUSTABLE, PLASTIC
0054	00002.000	0972988-0018	SCREW 4-40 X .625 PAN HEAD CRES
0055	00005.000	0972988-0026	SCREW 6-32 X .250 PAN HEAD CRES
0056	00007.000	0972988-0028	SCREW 6-32 X .375 PAN HEAD CRES
0057	00001.000	0972988-0031	SCREW 6-32 X .625 PAN HEAD CRES
0058	00001.000	0999823-0001	CABLE ASSY, GROUND
0059	00002.000	0972969-0006	SCREW #6-20 X 1/2 LG THD PL HEX WASHER
0060	00002.000	0972679-0013	SCREW # 6-19 X 1/2 SLETTED HEX
0061	00002.000	0972684-0011	SCREW, THREAD FORMING, #6-32
0062	00004.000	0972684-0013	SCREW, THD FRMG, HEX-WSHR HD, 6-32X.625LG
0067	00001.000	0996300-0003	SCREW #10-32 MACHINE, PAN HEAD
0068	00005.000	0972986-0008	SCREW 10-32 .375 PAN HEAD CRES
0071	00004.000	0996596-0041	SCREW, CAP, SOCKET HEAD, .500
0074	00002.000	0416622-0011	WASHER #4 FLAT
0075	00002.000	0411104-0135	WASHER, LOCK-SPRING, HELICAL, #4
0076	00001.000	0411100-0071	LOCKWASHER #6 INTERNAL TOOTH CRES
0077	00010.000	0416622-0013	WASHER #6 FLAT
0078	00010.000	0411104-0136	WASHER, LOCK-SPRING, HELICAL, #6
0079	00006.000	0411101-0058	LOCKWASHER #6 EXTERNAL TOOTH CRES
0080	00001.000	0416622-0033	WASHER #10 FLAT
0081	00001.000	0411104-0138	WASHER, LOCK-SPRING, HELICAL, #10
0082	00005.000	0411101-0060	LOCKWASHER #10 EXTERNAL TOOTH CRES
0083	00004.000	0411027-0810	WASHER .281 X .065 FLAT CRES
0084	00004.000	0411104-0139	WASHER, LOCK-SPRING, HELICAL, 1/4

LIST OF MATERIALS

DATE: 08-06-79
P/N: 2206573

Mechanism, 10/16 CPI

000 1
REV *

PRINT ITEM NUMBER	QUANTITY PER ASSEMBLY	PART NUMBER	DESCRIPTION
0086	00002.000	0411115-0044	NUT, 4-40 HEXAGON CRES STEEL
0088	00004.000	0416453-0022	NUT, PLAIN 6-32 UNC-2B HEX CRES, SMALL
0090	00001.000	0416453-0024	NUT, #10 HEX SMALL PATTERN
0091	AR	0232334-6050	LUBRICANT SILICONE GRS 1T GR 2 OZ TUBE
0092	AR	0996622-0001	OIL, TURBINE-GRADE 32
0093	00001.000	0232208-7000	LABEL 1X3INS RECTL SELF-ADHESIVE
0094	REF	0994396-9901	PROCEDURE, SITE & DATE CODE SERIALIZATION

LIST OF MATERIALS

DATE 08-06-79
P/N 2206573

Mechanism, 10/16 CPI

000 2
REV *

PRINT ITEM NUMBER	QUANTITY PER ASSEMBLY	PART NUMBER	DESCRIPTION
0001	00001.000	0999715-0001	SIDE PLATE,DRIVE MECHANISM-RIGHT SIDE
0002	00001.000	0999715-0002	SIDE PLATE,DRIVE MECHANISM-LEFT SIDE
0003	00001.000	0999724-0001	PLATEN, 820 TERMINAL
0004	00001.000	0994210-0001	PAPER GUIDE,PLATEN
0005	00001.000	0999725-0001	RETAINER, PAPER-PLATEN
0006	00001.000	0994186-0002	SPACER,LOWER REAR .250 HOLE DIA 820CPNTR
0007	00001.000	0999705-0001	RCD,GUIDE-LOWER
0008	00001.000	0994490-0001	GUIDE RCD, UPPER
0009	00001.000	0994197-0001	BUSHING,GUIDE RCD
0010	00001.000	0999726-0001	LEVER, ADJUSTMENT- PRINTHEAD
0011	00001.000	0999913-0001	CARRIAGE ASSY, PRINTHEAD
0012	00001.000	0999727-0001	BUMPER,CARRIAGE-RIGHT
0013	00001.000	0999727-0002	BUMPER,CARRIAGE-LEFT
0014	00001.000	0994232-0001	SCALE,HEAD GAP
0015	00001.000	0994194-0001	SUPPORT,IDLER PULLEY
0016	00001.000	0994195-0001	SPACER,IDLER PULLEY
0017	00001.000	0994241-0001	PULLEY ASSY,IDLER
0018	00001.000	0994454-0001	SPRING,GROUNDING
0019	00001.000	0994203-0001	SPRING,TENSION WIRE ROPE
0020	00001.000	0999703-0001	CRADLE, MOTOR
0021	00001.000	0994238-0004	CARRIAGE DR MOTOR ASSY 10016.5CPI(820)
0021A			M3
0022	00001.000	0994201-0001	STRAP,MOTOR
0023	00001.000	0994202-0001	NUT,MOTOR STRAP
0024	00001.000	0994233-0001	WIRE ROPE,DRIVE MECHANISM
0025	00001.000	0996158-0003	TRACTOR,PAPER,PREC. PR RT & LF HAND
0027	00001.000	0994209-0001	RUD,TRACTOR SUPPORT
0028	00001.000	0994172-0001	DRIVE SHAFT,TRACTOR
0029	00001.000	0999780-0001	GEAR ASSY, PAPER ADVANCE
0030	00001.000	0994173-0001	HUB,PAPER ADVANCE
0031	00001.000	0994302-0001	SPRING,COMPRESSION-PAPER DRIVE SHAFT
0032	00002.000	0999729-0001	BEARING, PAPER ADVANCE
0033	00001.000	0999829-0001	MOTOR ASSEMBLY, PAPER DRIVE
0033A			M1
0034	00002.000	0999731-0001	HOUSING,RIBBON GUIDE-SIDE PLATE
0035	00001.000	0999704-0001	CLAMP, WIRE ROPE
0036	00001.000	0999732-0001	PRINTHEAD ASSEMBLY,30VCLT

LIST OF MATERIALS

DATE: 08-06-79
P/N 2206573

Mechanism, 10/16 CPI

000 2
REV *

PRINT ITEM NUMBER	QUANTITY PER ASSEMBLY	PART NUMBER	DESCRIPTION
0037	00002.000	0994199-0001	NUT, PRINTHEAD
0038	00001.000	0999698-0001	NOSEGUIDE, PRINTHEAD
0039	00001.000	0999687-0001	RIBBON CRIVE
0041	00001.000	0999735-0001	CABLE ASSY, PAPER OUT
0042	00001.000	0999736-0001	CABLE ASSY, CARRIAGE DRIVE
0044	00001.000	0996169-0001	SWITCH, SENSITIVE
0044A			S99
0045	00006.000	0999697-0001	ROLLER, RIBBON
0046	00006.000	0411059-0169	RIVET-TUBULAR, .680LG, .123NCM SZ, OVAL HD
0047	00001.000	0983903-0002	CLIP, CABLE
0048	00001.000	0999791-0001	CABLE ASSY, PRINTHEAD
0049	00001.000	0999928-0001	GROUND STRAP, CARRIAGE MOTOR
0051	00001.000	0416402-4031	RING, RETAINING, EXTERNAL "E"
0052	00001.000	0411778-0005	RING, RETAINING, EXTERNAL BOWED
0053	00004.000	0418212-0040	STRAP, TIEDOWN, ADJUSTABLE, PLASTIC
0054	00002.000	0972988-0018	SCREW 4-40 X .625 PAN HEAD CRES
0055	00005.000	0972988-0026	SCREW 6-32 X .250 PAN HEAD CRES
0056	00007.000	0972988-0028	SCREW 6-32 X .375 PAN HEAD CRES
0057	00001.000	0972988-0031	SCREW 6-32 X .625 PAN HEAD CRES
0058	00001.000	0999823-0001	CABLE ASSY, GROUND
0059	00002.000	0972969-0006	SCREW #6-20 X 1/2 LG THD PL HEX WASHER
0060	00002.000	0972679-0013	SCREW # 6-19 X 1/2 SLCTED HEX
0061	00002.000	0972684-0011	SCREW, THREAD FORMING, #6-32
0062	00004.000	0972684-0013	SCREW, THD FRMG, HEX-WSHR HD, 6-32X.625LG
0067	00001.000	0996300-0003	SCREW #10-32 MACHINE, PAN HEAD
0068	00005.000	0972986-0008	SCREW 10-32 .375 PAN HEAD CRES
0071	00004.000	0996596-0041	SCREW, CAP, SOCKET HEAD, .500
0074	00002.000	0416622-0011	WASHER #4 FLAT
0075	00002.000	0411104-0135	WASHER, LOCK-SPRING, HELICAL, #4
0076	00001.000	0411100-0071	LOCKWASHER #6 INTERNAL TOOTH CRES
0077	00010.000	0416622-0013	WASHER #6 FLAT
0078	00010.000	0411104-0136	WASHER, LOCK-SPRING, HELICAL, #6
0079	00006.000	0411101-0058	LOCKWASHER #6 EXTERNAL TOOTH CRES
0080	00001.000	0416622-0033	WASHER #10 FLAT
0081	00001.000	0411104-0138	WASHER, LOCK-SPRING, HELICAL, #10
0082	00005.000	0411101-0060	LOCKWASHER #10 EXTERNAL TOOTH CRES

LIST OF MATERIALS

DATE 08-06-79
P/N 2206573

Mechanism, 10/16 CPI

000 2
REV *

PRINT ITEM NUMBER	QUANTITY PER ASSEMBLY	PART NUMBER	DESCRIPTION
0083	00004.000	0411027-0810	WASHER, 281 X .065 FLAT CRES
0084	00004.000	0411104-0139	WASHER, LOCK-SPRING, HELICAL, 1/4
0086	00002.000	0411115-0044	NUT, 4-40 HEXAGON CRES STEEL
0088	00004.000	0416453-0022	NUT, PLAIN 6-32 UNC-2B HEX CRES, SMALL
0090	00001.000	0416453-0024	NUT, #10 HEX SMALL PATTERN
0091	AR	0232334-6050	LUBRICANT SILICONE GRS LT GR 2 OZ TUBE
0092	AR	0996622-0001	OIL, TURBINE-GRADE 32
0093	00001.000	0232208-7000	LABEL 1X3INS RECTL SELF-ADHESIVE
0094	REF	0994396-9901	PROCEDURE, SITE & DATE CODE SERIALIZATION

6-67

NOTES UNLESS OTHERWISE SPECIFIED

DWG. NO. 0999972		REV.	DESCRIPTION	DATE	APPROVED
----------------------------	--	------	-------------	------	----------

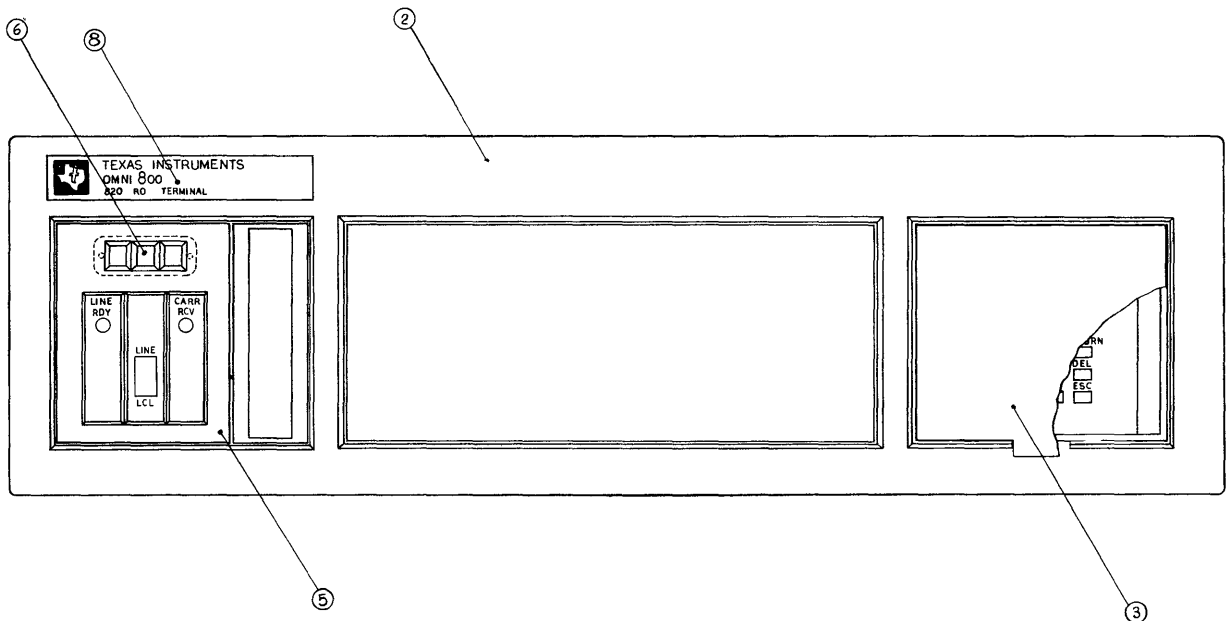

SEQ. NO.	IDENT	F.SPEC.	NO.	ADDITIONAL CLASSIFICATION	NOTES

QTY	ITEM NO.	PART OR IDENTIFYING NUMBER	NOMENCLATURE OR DESCRIPTION	PROCUREMENT SPECIFICATION	NOTES

TEXAS INSTRUMENTS
INCORPORATED
DALLAS, TEXAS

CONTROL PANEL ASSY.
820 RO

DATE: 3/16/72
DRAWN: J. Young
CHECKED: Dave Schuler 3-29-72
APP'D: J. Young
DATE: 3/30/72

SCALE 1/1

LIST OF MATERIALS

DATE 03-27-79
 P/N 0999972

Control Panel Assy, 820 RO

000 1
 REV *

PRINT ITEM NUMBER	QUANTITY PER ASSEMBLY	PART NUMBER	DESCRIPTION
0001	00001.000	0999953-0101	KYBD, 820 RO ASCII
0002	00001.000	0999963-0001	BEZEL, KEYBOARD, 820 RO
0003	00001.000	0999967-0001	DOOR BEZEL, 820 RO
0004	00002.000	0999968-0001	SPRING, LEAF, BEZEL DOOR
0005	00001.000	0999966-0001	PLATE, BEZEL, 820 RO
0006	00001.000	0999733-0001	FILTER, KEYBOARD PLATE
0007	00002.000	0972988-0013	SCREW 4-40 X .250 PAN HEAD CRES
0008	00001.000	0999977-0001	NAMEPLATE, 820 RO
0009	00002.000	0416622-0011	WASHER #4 FLAT

8

7

6

5

4

3

1

DWG NO 999974

REV

REVISIONS

REV	DESCRIPTION	DATE	APPROVED
A	CN 433427 ADDED -0401 LM	6-19-79	D. Starn

NOTES UNLESS OTHERWISE SPECIFIED

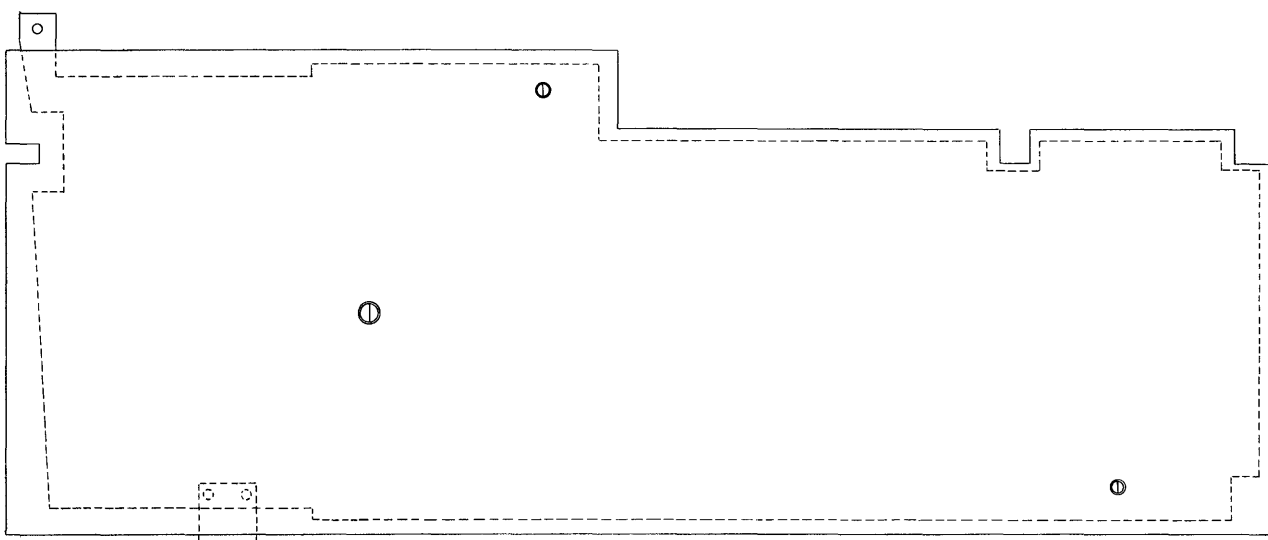

PART NO	DESCRIPTION	REMARKS
999974-0401	TERM ELECTRONICS W/GND PLANE (230V-BPO)	BRITISH POST OFFICE
999974-0201	TERM ELECTRONICS W/GND PLANE (230V)	EUROPEAN
999974-0101	TERM ELECTRONICS W/GND PLANE (115V)	DOMESTIC

69-9

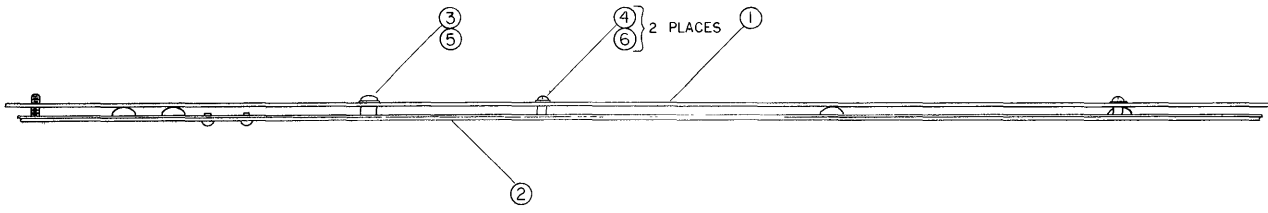

SEQ NO	IDENT	F SPEC	NO	ADDITIONAL	NOTES
	PROCESS			CLASSIFICATION	

PROCESSES — FOR CORRELATION TO GOVT/IND SPECIFICATIONS SEE TI DRAWING 729497

QTY	ITEM NO	PART OR IDENTIFYING NUMBER	NOMENCLATURE OR DESCRIPTION	PROCUREMENT SPECIFICATION	NOTES
			PARTS LIST		
			UNLESS OTHERWISE SPECIFIED • DIMENSIONS ARE IN INCHES • TOLERANCES ANGLES ±1° • 3 PLACE DECIMALS = 010 • 2 PLACE DECIMALS = 02 • INTERPRET DRAWING PER MIL D 3000 • REMOVE ALL BURRS AND SHARP EDGES • CONCENTRICITY MACHINED DIAMETERS .010 FRA • DIMENSIONAL LIMITS APPLY BEFORE PROCESSES • PARENTHETICAL INFO FOR REF ONLY		
			HOLE TOLERANCE .013 + .004 .125 + .005 .251 + .008 .125 - .001 .250 - .001 .500 - .001 .500 + .008 .751 + .010 1.001 + .012 .750 - .001 1.000 - .001 2.000 - .001		
	999690	874C	DATE: 3/13/79 DRAWN BY: [Signature] CHECKED BY: [Signature] DATE: 5-1-79 DATE: 7/17 DATE: 5/4/79		
			TEXAS INSTRUMENTS INCORPORATED DALLAS, TEXAS TERMINAL ELECTRONICS WITH GND PLANE		
			DRAWING NO: D196214 SCALE: 1/11	DRAWN BY: 999974 SHEET: FILMED	

8

7

6

5

4

3

2

LM

1

30

LIST OF MATERIALS

DATE 06-01-79
P/N 0999974

Terminal Electronics w/Ground Plane

0101
REV A

PRINT ITEM NUMBER	QUANTITY PER ASSEMBLY	PART NUMBER	DESCRIPTION
0001	00001.000	0999947-0101	TERMINAL ELECTRONICS, 115 V
0002	00001.000	0999872-0001	GROUND PLNE ASSY
0003	00001.000	0972988-0041	SCREW 8-32 X .250 PAN HEAD CRES
0004	00002.000	0972988-0013	SCREW 4-40 X .250 PAN HEAD CRES
0005	00001.000	0411101-0059	LOCKWASHER # 8 EXTERNAL TOOTH CRES
0006	00002.000	0411101-0057	LOCKWASHER # 4 EXTERNAL TOOTH CRES

DATE 06-01-79
P/N 0999974

Terminal Electronics w/Ground Plane

000 0201
REV A

0001	00001.000	0999947-0201	TERMINAL ELECTRONICS, 230 V
0002	00001.000	0999872-0001	GROUND PLNE ASSY
0003	00001.000	0972988-0041	SCREW 8-32 X .250 PAN HEAD CRES
0004	00002.000	0972988-0013	SCREW 4-40 X .250 PAN HEAD CRES
0005	00001.000	0411101-0059	LOCKWASHER # 8 EXTERNAL TOOTH CRES
0006	00002.000	0411101-0057	LOCKWASHER # 4 EXTERNAL TOOTH CRES

LIST OF MATERIALS

DATE 06-01-79
P/N 0999974

Terminal Electronics w/Ground Plane

000 0401
REV A

PRINT ITEM NUMBER	QUANTITY PER ASSEMBLY	PART NUMBER	DESCRIPTION
0001	00001.000	0999947-0401	TERM ELECTRONICS, 230V (BPO)
0002	00001.000	0999872-0001	GROUND PLNE ASSY
0003	00001.000	0972988-0041	SCREW 8-32 X .250 PAN HEAD CRES
0004	00002.000	0972988-0013	SCREW 4-40 X .250 PAN HEAD CRES
0005	00001.000	0411101-0059	LOCKWASHER # 8 EXTERNAL TOOTH CRES
0006	00002.000	0411101-0057	LOCKWASHER # 4 EXTERNAL TOOTH CRES

DWG NO 999947

NOTES UNLESS OTHERWISE SPECIFIED

REV	DESCRIPTION	DATE	APPROVED
A	CN 439523 LM UPDATE	5-3-79	D. Starn
B	CN 431049 LM UPDATE	5-3-79	D. Starn
C	CN 451052 LM UPDATE	5-3-79	D. Starn
D	CN 443621 LM UPDATE	5-3-79	D. Starn
E	CN 438088 LM UPDATE	5-3-79	D. Starn
F	CN 438090 LM UPDATE	5-3-79	D. Starn
G	CN 438092 LM UPDATE	5-3-79	D. Starn
H	CN 438093 C. Starn	6/20/79	D. Starn
I	LM -101 & 102 ITEM 99 QTY WAS 1		
J	CN 433475 J. Starn	8/21/79	D. Starn
K	CN 433445 J. Starn	8/21/79	D. Starn
L	CN 433476 J. Starn	8/21/79	D. Starn
M	CN 433468 J. Starn	8/21/79	D. Starn
N	CN 433477 J. Starn	8/21/79	D. Starn
P	CN 434014 J. Starn	8/21/79	D. Starn

- | | | |
|---|---|--|
| <p>1 MOUNT DISC (ITEM 209) CONCENTRICALLY TO SUPPORT (ITEM 178) USING SILICONE RTV (ITEM 200)</p> <p>2 MARK SITE/DATE CODE ON ASSEMBLY IN POSITION INDICATED PER 994396 (ITEM 235), PARAGRAPH 4.0 AND PROCESS 1</p> <p>3 MARK APPROPRIATE DASH NUMBER AND REVISION LETTER PER PROCESS 1</p> <p>4 INSTALL SELF-CLINCHING STUDS (ITEM 206) BEFORE PROCESS 2</p> <p>5 R124 IS TO BE SELECTED TO A TOLERANCE OF $\pm .5\%$ $\pm .2\%$ AND MARKED WITH A YELLOW DOT</p> <p>6  INDICATES COMPONENTS NOT USED</p> <p>7 ORIENT BOTH CONNECTORS (ITEM 185) USING VENDOR IDENTIFICATION MOLDED INTO PART AND POSITION AS SHOWN</p> <p>8 ITEM 190 MAY BE SUBSTITUTED FOR ITEM 189 FOR REWORK NEED ONLY</p> <p>9 INSTALL TEST JUMPER PLUGS (ITEM 192) AFTER ASSEMBLY FINAL TEST (E3 & E4) (E5 & E6) (E15 & E16) (E205 & E206) (E207 & E208) (E209 & E210) (E211 & E212) (E213 & E214) (E215 & E216) (E219 & E220) (E234 & E235) (E262 & E263) (E264 & E265)</p> <p>10 INSTALL TEST SOCKET (ITEM 173) FROM CONDUCTOR SIDE OF BOARD</p> | <p>11 SEE VIEW L SH 6 (C-2) FOR ALL SINGLE TRANSISTORS TO HEATSINK HARDWARE STACK DETAIL EXCEPT Q255, AND VIEW M SH 6 (A-2) FOR DOUBLE TRANSISTOR TO HEATSINK HARDWARE STACK DETAIL. SEE VIEW P SH 6 (C-7) FOR Q255 TRANSISTOR TO HEATSINK HARDWARE STACK DETAIL</p> <p>12 TORQUE TO BE $35 \pm .5$ IN-LBS</p> <p>13 APPLY THERMAL COMPOUND (ITEM 202) BETWEEN NETWORKS (ITEM 10) AND HEATSINK (ITEM 198) (3 PLACES) AFTER PROCESS 2 AND RETORQUE HARDWARE</p> <p>14 RESISTOR (ITEM 118) OMITTED FROM PLAN VIEW FOR CLARITY</p> <p>15 SECURE TOROID (ITEM 174) AND COMPLETE ELECTRICAL CONNECTIONS USING BUS WIRE (ITEM 224) BETWEEN TERMINALS E250 TO E251, E252 TO E253, E254 TO E255, E256 TO E257, E258 TO E259 AND E260 TO E261</p> <p>16 FOR 115 VOLT ASSEMBLY (-101) INSTALL THERMISTORS (ITEM 183) IN LOCATIONS R272 AND R273. FOR 230 VOLT ASSEMBLY (-201, -401) INSTALL THERMISTORS (ITEM 183) IN LOCATIONS R274 AND R275 AND CONNECT E285 TO E286 USING BUSS WIRE (ITEM 224)</p> <p>17 ITEMS 108, 119, 120, 145 AND 146 TO BE INSTALLED WITH A CLEARANCE OF .020 (MIN) AND .120 (MAX) BETWEEN COMPONENT BODY AND PWB (ITEM 1)</p> | <p>18. MAX LEAD LENGTH BELOW SURFACE OF BOARD .07</p> <p>19 TIGHTEN TRANSISTOR MOUNTING HARDWARE ON HEATSINKS (ITEM 195, 196 AND 197) TO $4.0 \pm .5$ IN-LBS AND OTHER HARDWARE ON HEATSINKS TO $6.0 \pm .5$ IN-LBS</p> <p>20 SOLDER GROUND WIRES (ITEMS 186 AND 187) TO PWB PER PROCESS 3 AND REF DESIGNATOR INDICATED</p> <p>21. SECURE CAP (ITEM 169) TO PWB WITH A 1-INCH MINIMUM BEAD OF RTV (ITEM 200) ALONG EACH ACCESSABLE SIDE AND BETWEEN ADJACENT CAPACITORS</p> <p>22 FOR -0101 AND -0201 ASSEMBLIES INSTALL SIG/CHASSIS GND OPTION CABLE (ITEM 188) BETWEEN E221 AND E222 AFTER PROCESS 2 [REF ONLY: CUSTOMER COMMUNICATIONS OPTION CONNECTION (SIG GND TO PROTECTIVE GND E221 TO E223)] SEE VIEW K SH 4 (A-2). FOR -0401 ASSEMBLY INSTALL BUS WIRE (ITEM 223) BETWEEN E221 AND E223 PER PROCESS 3, SEE VIEW R SH 5 (B-7)</p> <p>23 SECURE BATTERY (ITEM 231) USING SILICONE RTV (ITEM 200)</p> <p>24 SEE VIEW N SH 3 (C-7) FOR INSTALLATION OF ITEM 37 AND ITS SUBSTITUTE PART (ITEM 234) AND PCB MODIFICATION</p> |
|---|---|--|

999947-0401	TERMINAL ELECTRONICS, 230 VOLT	BPO
999947-0201	TERMINAL ELECTRONICS, 230 VOLT	EUROPEAN
999947-0101	TERMINAL ELECTRONICS, 115 VOLT	DOMESTIC
PART NUMBER	DESCRIPTION	REMARKS

REV STATUS PKJMKM OF SHEETS 11213141516

ITEM NO	QTY	PART OR IDENTIFYING NUMBER	NOMENCLATURE OR DESCRIPTION	PROCUREMENT SPECIFICATION	NOTES																		
PARTS LIST																							
<ul style="list-style-type: none"> UNLESS OTHERWISE SPECIFIED TOLERANCES - ANGLES $\pm .1^\circ$ DIMENSIONS ARE IN INCHES 3 PLACE DECIMALS = .010 2 PLACE DECIMALS = .02 INTERPRET DRAWING PER MIL-D-100 REMOVE ALL BURRS AND SHARP EDGES CONCENTRICITY MACHINED DIAMETERS, OLD FIM DIMENSIONAL LIMITS APPLY BEFORE PROCESSES PARENTHETICAL INFO FOR REF ONLY 																							
<table border="0"> <tr> <td>013 + .004</td> <td>128 + .005</td> <td>281 + .009</td> </tr> <tr> <td>THRU .001</td> <td>THRU .001</td> <td>THRU .001</td> </tr> <tr> <td>129</td> <td>250</td> <td>900</td> </tr> <tr> <td>201 + .008</td> <td>751 + .010</td> <td>1301 + .012</td> </tr> <tr> <td>THRU .001</td> <td>THRU .001</td> <td>THRU .001</td> </tr> <tr> <td>750</td> <td>1300</td> <td>2300</td> </tr> </table>						013 + .004	128 + .005	281 + .009	THRU .001	THRU .001	THRU .001	129	250	900	201 + .008	751 + .010	1301 + .012	THRU .001	THRU .001	THRU .001	750	1300	2300
013 + .004	128 + .005	281 + .009																					
THRU .001	THRU .001	THRU .001																					
129	250	900																					
201 + .008	751 + .010	1301 + .012																					
THRU .001	THRU .001	THRU .001																					
750	1300	2300																					
999974	8740																						
<table border="0"> <tr> <td>DATE</td> <td>DATE</td> <td>DATE</td> </tr> <tr> <td>8/21/79</td> <td>8/21/79</td> <td>8/21/79</td> </tr> <tr> <td>APPROVED</td> <td>APPROVED</td> <td>APPROVED</td> </tr> <tr> <td><i>[Signature]</i></td> <td><i>[Signature]</i></td> <td><i>[Signature]</i></td> </tr> </table>						DATE	DATE	DATE	8/21/79	8/21/79	8/21/79	APPROVED	APPROVED	APPROVED	<i>[Signature]</i>	<i>[Signature]</i>	<i>[Signature]</i>						
DATE	DATE	DATE																					
8/21/79	8/21/79	8/21/79																					
APPROVED	APPROVED	APPROVED																					
<i>[Signature]</i>	<i>[Signature]</i>	<i>[Signature]</i>																					
<table border="0"> <tr> <td>SIZE (FSCM NO)</td> <td>DRAWING NO</td> </tr> <tr> <td>D196214</td> <td>999947</td> </tr> <tr> <td>SCALE 1/1</td> <td>SHEET 1 OF 6</td> </tr> </table>						SIZE (FSCM NO)	DRAWING NO	D196214	999947	SCALE 1/1	SHEET 1 OF 6												
SIZE (FSCM NO)	DRAWING NO																						
D196214	999947																						
SCALE 1/1	SHEET 1 OF 6																						

REV	DATE	BY	CHKD	DESCRIPTION
3	SLDR 127-02	00		
2	SLDR 124-00	00		
1	MARK 100-02	21		HEIGHT .06, COLOR. BLACK

IDENT	F SPEC	NO	ADDITIONAL	NOTES
PROCESS			CLASSIFICATION	

PROCESSES - FOR CORRELATION TO GOVT/IND SPECIFICATIONS SEE 'I' DRAWING 729467

6-72

D

C

B

A

5

D

23

C

B

A

32

LM 1

8 7 6 5 4 3 2 1

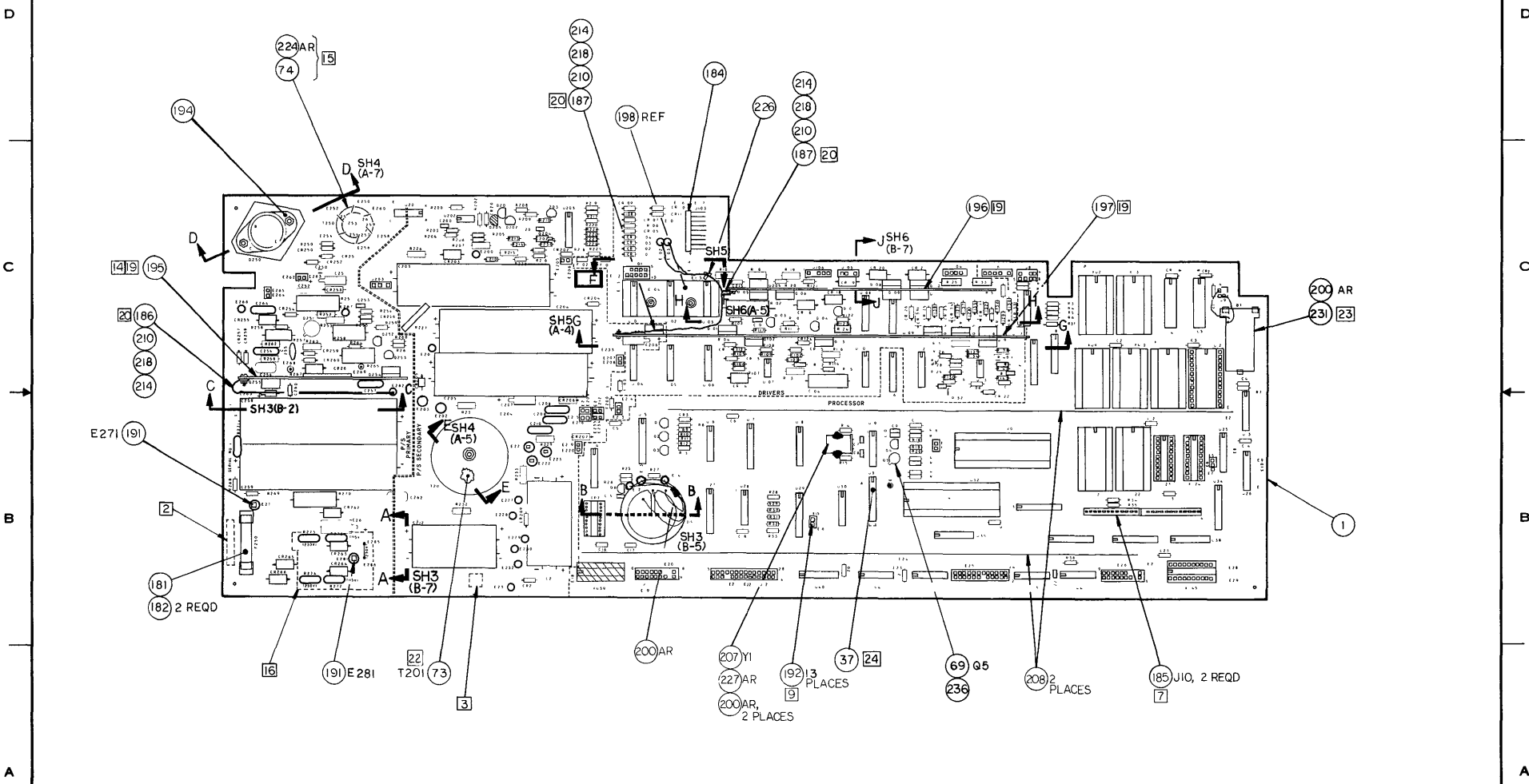

6-73

8 7 6 5 4 3 2 1

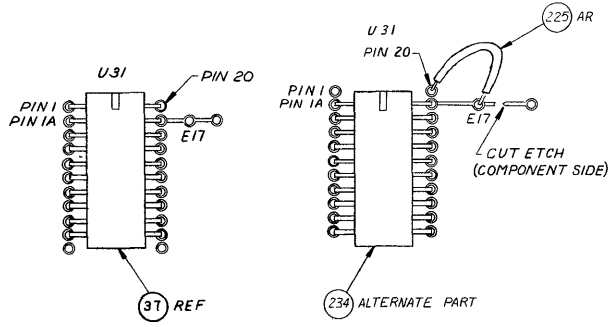

VIEW N
SH 1 (B-4)
SCALE: NONE

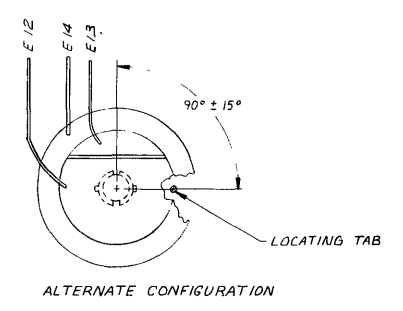

ALTERNATE CONFIGURATION

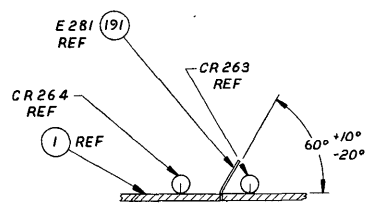
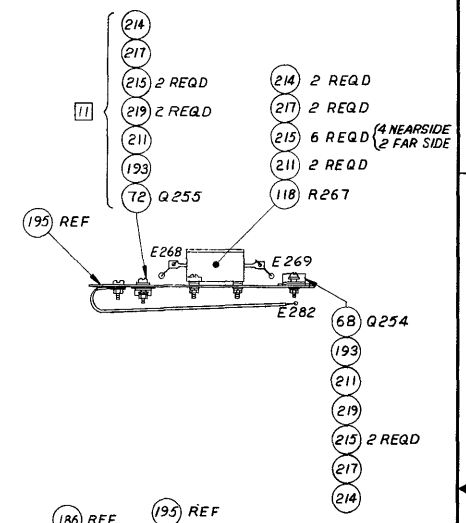

VIEW A-A
SH 2 (B-6)
SCALE: 2/1
ROTATED 90°
CLOCKWISE

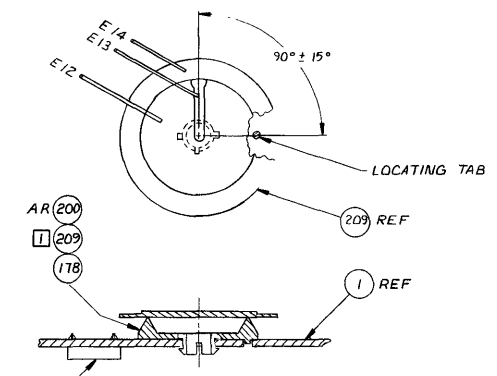

SECTION B-B
SH 2 (B-5)
SCALE: 2/1

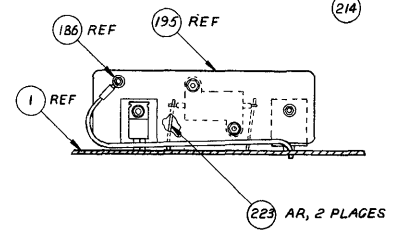

VIEW C-C
SH 2 (B-7)

6-74

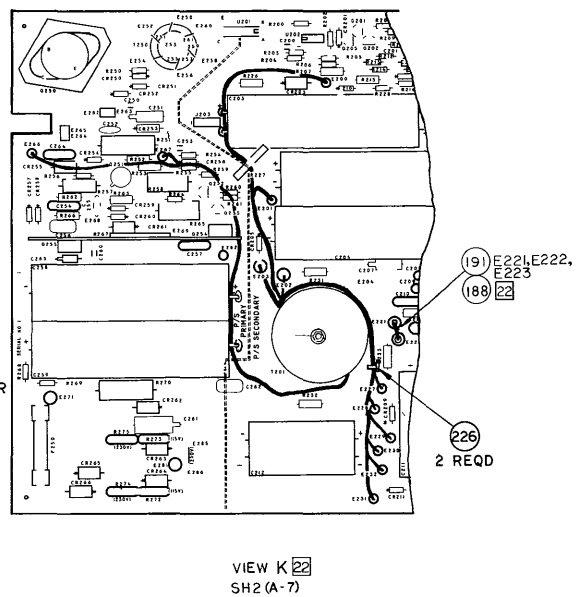
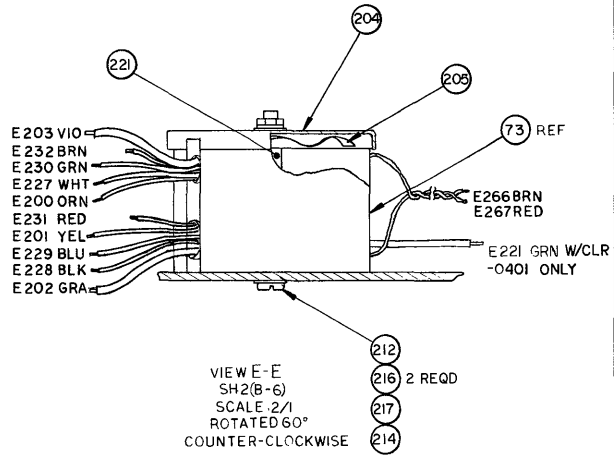
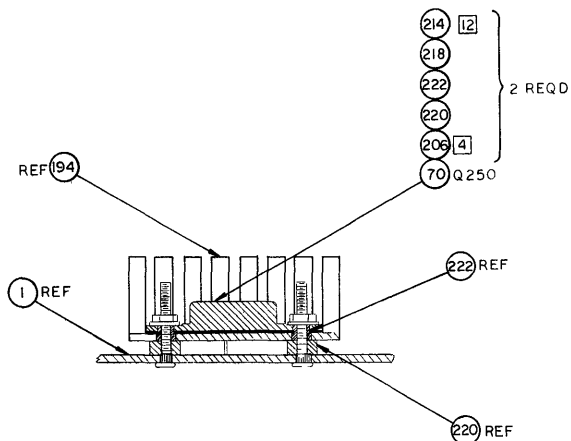
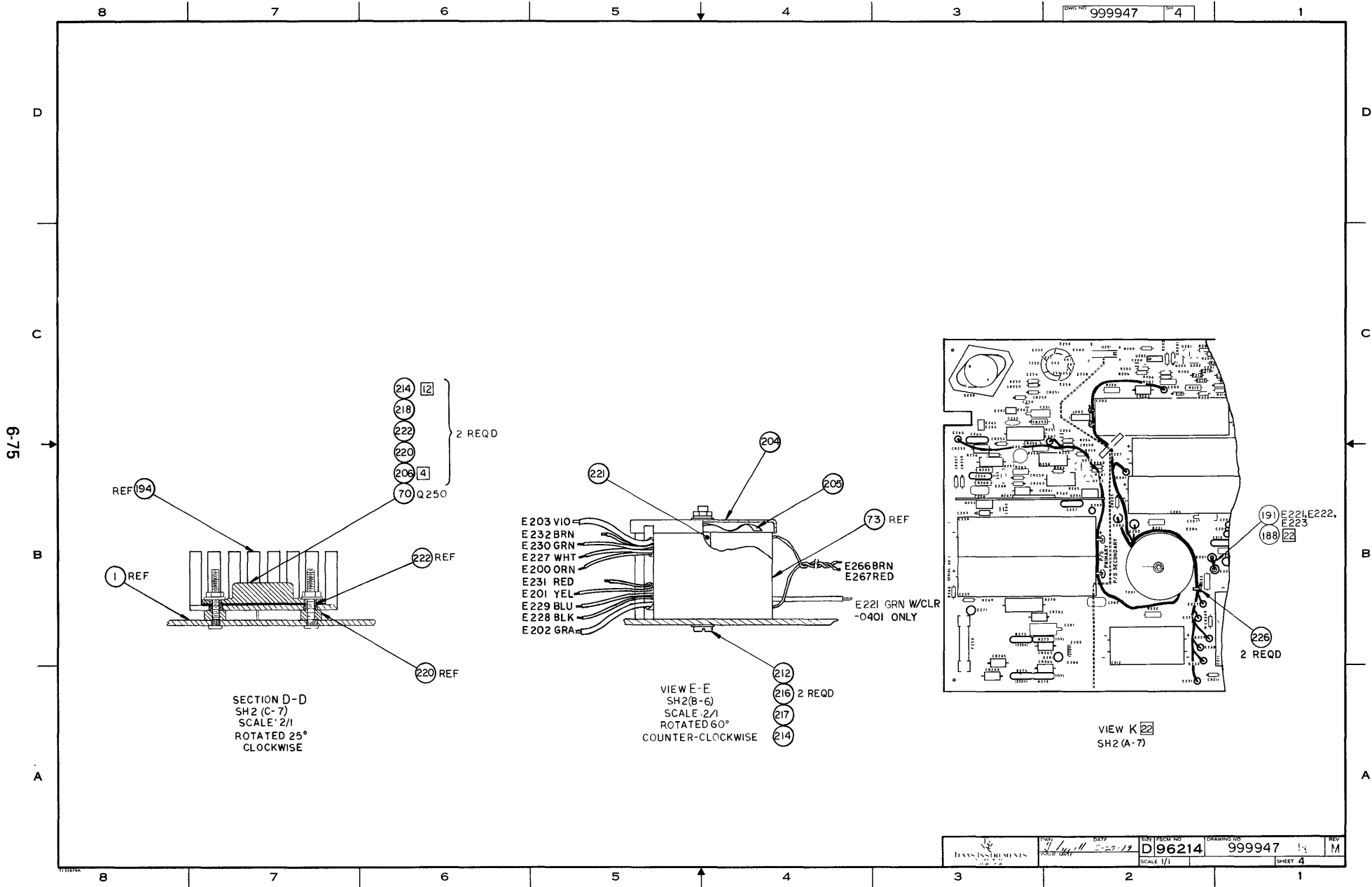

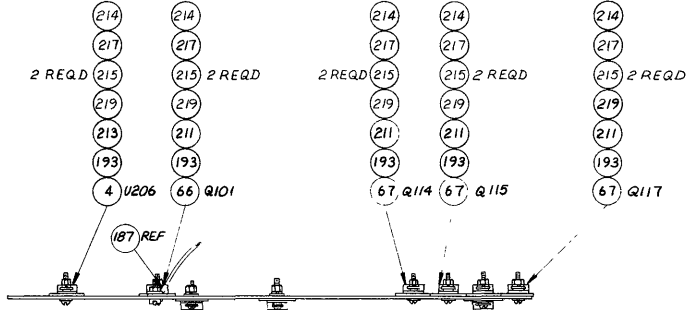
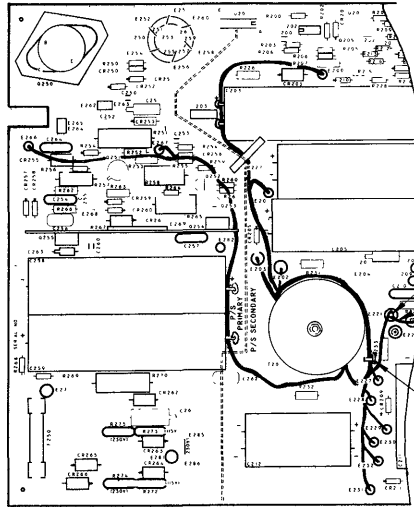

VIEW R 22
SH 2 (A-7)

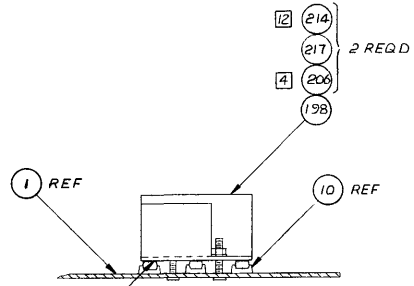

VIEW F-F
SH 2 (C-5)
ROTATED 180°

3 AR 202

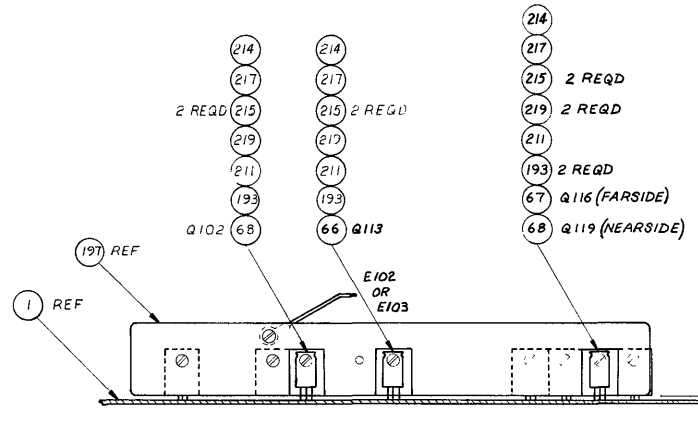

VIEW G-G
SH 2 (C-6)

97-9

8 7 6 5 4 3 2 1

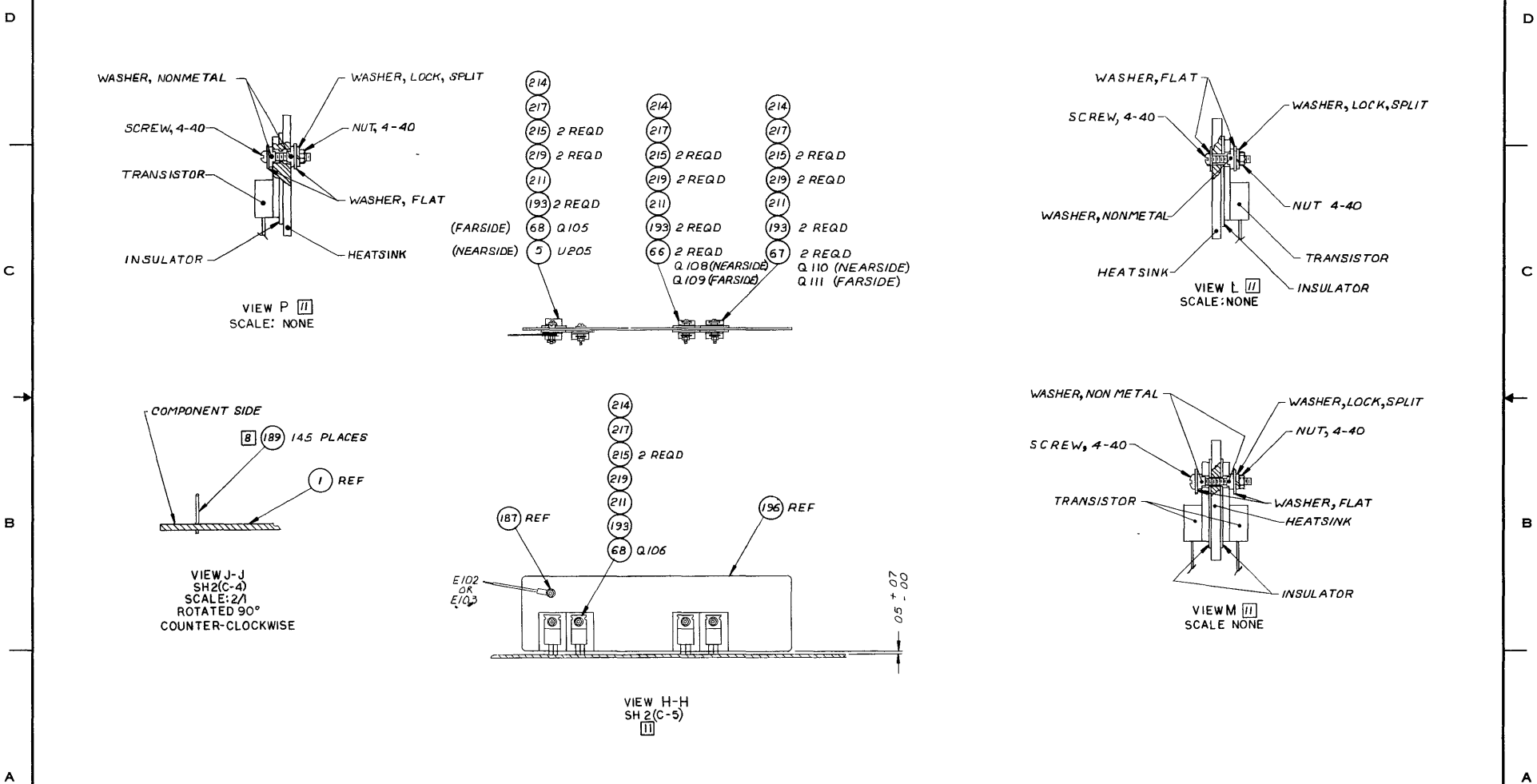

6-77

8 7 6 5 4 3 2 1

LIST OF MATERIALS

Terminal Electronics PWB

DATE 8/20/79
P/N 999947-0101

0101
REV P

PRINT ITEM NUMBER	QUANTITY PER ASSEMBLY	PART NUMBER	DESCRIPTION
0001	00001.000	0999946-0001	PWB, TERMINAL ELECTRONICS
0002	REF	0999945-0001	DIAG, LOGIC, DETAILED TERMINAL ELECT
0003	00001.000	0222224-2741	NETWORK SN72741P OPERATIONAL AMP
0003A			U202
0004	00001.000	0972499-0002	NETWORK, VOLG REG, NEG, 3 TERM-(-12V)
0004A			U206
0005	00001.000	0972872-0012	NETWORK, LM 340-12T VOLTAGE REGULATOR
0005A			U205
0006	00001.000	0972663-0001	NETWORK, LM339N
0006A			U203
0007	00002.000	0996709-0001	IC, LM393P DIFFERENTIAL COMPARATOR
0007A			U107, U113
0008	00001.000	0996594-0001	ISOLATOR, OPTICALLY COUPLED
0008A			U201
0009	00000.000	2210036-0001	IC, OPTICALLY COUPLED ISOLATOR
0009A			U201, ITEM 9 MAY BE
0009B			SUBSTITUTED AS AN ALTERNATE
0009C			FOR ITEM 8
0010	00003.000	0996727-0002	IC, ULN2065B, DARLINGTON QUAD
0010A			U101, U102, U103
0012	00002.000	0972141-0031	NETWORK, RES. 390 OHM 2 & 14 PIN DIP
0012A			U106, U109
0013	00001.000	0800118-0015	RESISTOR 6.8KOHMS DIL PULL UP 16 PINS
0013A			U38
0014	00001.000	0972037-1910	NETWORK, RES 16 PIN 8 ELEM- 91.00 OHMS
0014A			U14
0015	00001.000	2210301-0001	IC, MICROPROCESSOR, CPU
0015A			U20
0016	00001.000	2210307-0004	IC, (USART) SERIAL I/O, SIO/9 CHAN A ONLY
0016A			U32
0017	00000.000	2210307-0001	IC, (USART) SERIAL I/O, SIO/0 BONDING
0017A			U32, ITEM 17 MAY BE
0017B			SUBSTITUTED AS AN ALTERNATE
0017C			FOR ITEM 16
0018	00000.000	2210307-0002	IC, (USART) SERIAL I/O, SIO/1 BONDING
0018A			U32, ITEM 18 MAY BE
0018B			SUBSTITUTED AS AN ALTERNATE
0018C			FOR ITEM 16

LIST OF MATERIALS

DATE 8/20/79
P/N 999947-0101

Terminal Electronics PWB

REV 0101
P

PRINT ITEM NUMBER	QUANTITY PER ASSEMBLY	PART NUMBER	DESCRIPTION
00198	00000.000	2210307-0003	IC, (USART) SERIAL I/O, SIO/2 BONDING
0019C			U32, ITEM 19 MAY BE
0020	00002.000	2210302-0001	IC, COUNTER TIMER CKT, 28 PIN CERAMIC PKG
0020A			U21, U22
0021	00001.000	0996750-0001	IC, TMS-4732NLZA3226, 4096 X 8-BIT PREPGM
0021A			U11
0022	00001.000	2207625-0003	IC, 8K X 8 ROM 820 TERMINAL
0022A			U9
0023	00001.000	2207625-0004	IC, 8K X 8 ROM 820 TERMINAL
0023A			U10
0024	00002.000	0996203-0002	IC, S 5101L-1 1024BIT(256 X 4)ST CMOS RAM
0024A			U4, U5
0025	00002.000	2210363-0001	IC, 1K X 8-BIT RAM, 24-PIN, DUAL-IN-LINE
0025A			U2, U3
0026	00001.000	0972900-7402	NETWORK SN74LS02N
0026A			U110
0027	00001.000	0972900-7404	NETWORK SN74LS04N
0027A			U19
0028	00001.000	0222222-7406	NETWORK SN7406N
0028A			U28
0029	00001.000	0972749-0001	NETWORK, SN74LS08N
0029A			U16
0030	00001.000	0972784-0002	NETWORK SN74LS14N
0030A			U1
0031	00004.000	0222222-7417	NETWORK-SN7417N
0031A			U104, U105, U108, U112
0032	00001.000	0972900-7109	NETWORK SN74LS109N
0032A			U40
0033	00001.000	0996399-0001	IC, SN74LS107N DUAL-NEGATIVE-EDGE
0033A			U30
0034	00002.000	0972900-7138	NETWORK SN74LS138N
0034A			U25, U26
0035	00001.000	0972686-0001	NETWORK-QUAD MULTIPLEXER, SN74LS157N
0035A			U35
0036	00004.000	0996089-0004	IC, SN74LS244N LINE DRIVER
0036A			U17, U29, U33, U34

LIST OF MATERIALS

Terminal Electronics PWB

DATE 8/20/79
P/N 999947-0101

0101
REV P

PRINT ITEM NUMBER	QUANTITY PER ASSEMBLY	PART NUMBER	DESCRIPTION
0037	00001.000	0996755-0001	IC, SN74LS245N BUS XCVR TRANSITION
0037A			U31
0038	00002.000	0972120-0001	NETWORK, SN74259 8-BIT ADDRESSABLE LATCH
0038A			U18, U6
0039	00005.000	0996029-0001	IC, SN74LS273N OCTAL D-TYPE FLIP/FLOP
0039A			U7, U15, U27, U36, U37
0040	00002.000	0996015-0001	IC, QUAD LINE DRIVERS SN75188N
0040A			U41, U42
0041	00002.000	0972450-0002	NETWORK, SN75189AN/MC1489AL QUAD LINE RC
0041A			U43, U44
0042	00001.000	2206549-0001	PROM, PROGRAMMED, TACH PHASE DECODE
0042A			U8
0043	00001.000	2206550-0001	PROM, PROGRAMMED, MEMORY SELECT DECODE
0043A			U13
0044	00005.000	0972932-0001	SEMICONDUCTOR DEVICE, DIODE, IN914B
0044A			CR2, CR112, CR113, CR210, CR256
0045	00031.000	0539468-0002	DIODE, IN4002 1AMP 100PIV RECTIFIER
0045A			CR3, CR101-CR111, CR123-
0045B			CR132, CR135-CR138, CR204,
0045C			CR250-CR252, CR254
0046	00001.000	0539468-0007	DIODE, IN4007 1AMP 1000PIV RECTIFIER
0046A			CR258
0047	00001.000	0972116-0001	X DIODE UTG1249 (MAY USE IN5808/IN5809)
0047A			CR205
0048	00006.000	0996036-0003	DIODE, 3 AMP 100V RECTIFIER
0048A			CR114, CR116, CR118-CR121
0049	00001.000	0972164-0001	DIODE, MR501
0049A			CR255
0050	00005.000	0972164-0006	DIODE, 3 AMP 1,000V SILICONE
0050A			CR262-CR266
0051	00001.000	0803297-0001	DIODE, SCHOTTKY BARRIER, UHF MIXER
0051A			CR1
0052	00003.000	0972268-0006	DIODE IN4937 1 AMP
0052A			CR257, CR259, CR260
0053	00002.000	0972268-0002	DIODE IN4934-1 AMP
0053A			CR209, CR211
0054	00001.000	0996036-0004	DIODE, MR852 RECTIFIER SILICON FAST RCVY
0054A			CR203

LIST OF MATERIALS

Terminal Electronics PWB

DATE 8/20/79
P/N 999947-0101

0101
REV P

PRINT ITEM NUMBER	QUANTITY PER ASSEMBLY	PART NUMBER	DESCRIPTION
0055	00002.000	0972460-0007	DIODE, SILICON, ZENER 1X
0055A			CR201, CR202
0056	00002.000	0972460-0006	DIODE E7918, SILICON, ZENER-1X
0056A			CR115, CR122
0057	00001.000	0801295-0062	SEMICONDUCTOR DEVICE, DIODE 1N5338B 5W
0057A			CR253
0058	00001.000	0972118-0001	DIODE, 1N5339B
0058A			CR207
0059	00001.000	0972118-0005	SEMICONDUCTOR DEVICE, DIODE-1N5350B
0059A			CR206
0060	00004.000	0801295-0084	SEMICONDUCTOR DEVICE, DIODE 1N5360B 5W
0060A			CR117, CR133, CR134, CR139
0061	00001.000	0996036-0006	DIODE, MR856 RECTIFIER SILICON FAST RCVY
0061A			CR261
0062	00008.000	0972057-0001	TRANSISTOR-A5T2222 NPN SILICON
0062A			Q2, Q3, Q6, Q103, Q104, Q107
0062B			Q202, Q252
0063	00003.000	0800523-0001	TRANSISTOR A5T2907 PNP SILICON
0063A			Q1, Q203, Q253
0064	00001.000	0772116-0003	TRANSISTOR, SYMM N-CHANNEL FET T1S73
0064A			Q201
0065	00001.000	0972542-0001	TRANSISTOR, HV PNP FN5416/S41802
0065A			Q251
0066	00004.000	0996712-0001	TRANSISTOR, TIP105 P-N-P POWER
0066A			Q101, Q108, Q109, Q113
0067	00006.000	0996801-0001	TRANSISTOR, TIP100 N-P-N, DARLINGTON
0067A			Q110, Q111, Q114-Q117
0068	00005.000	0996711-0002	TRANSISTOR, TIP73A N-P-N POWER
0068A			Q102, Q105, Q106, Q119, Q254
0069	00001.000	0972955-0001	XSTR 2N2369A, NPN, HIGH SPEED SW, TO-18
0069A			Q5
0070	00001.000	0996703-0001	TRANSISTOR, 2N6545 NPN, 125 WATT POWER
0070A			Q250
0071	00001.000	0800257-0001	TRANSISTOR
0071A			Q4
0072	00001.000	0972465-0003	THYRISTORS, TRIODE-P-N-P-N SIL
0072A			Q255
0073	00001.000	0999789-0001	TRANSFORMER, SWITCH MODE, 820 PWR SUPPLY

LIST OF MATERIALS

DATE 8/20/79
P/N 999947-0101

Terminal Electronics PWB

0101
REV P

PRINT ITEM NUMBER	QUANTITY PER ASSEMBLY	PART NUMBER	DESCRIPTION
0073A			T201
0074	00001.000	0996873-0001	TOROID CORE
0074A			T250
0075	00002.000	0972946-0025	RES FIX 22.0 OHM 5 % .25 W CARBON FILM
0075A			R21,R22
0076	00001.000	0972946-0031	RES FIX 39.0 OHM 5 % .25 W CARBON FILM
0076A			R27
0077	00001.000	0972946-0129	RES FIX 470K OHM 5 % .25 W CARBON FILM
0077A			R217
0078	00004.000	0972946-0037	RES FIX 68.0 OHM 5 % .25 W CARBON FILM
0078A			R30-R33
0079	00001.000	0972946-0038	RES FIX 75.0 OHM 5 % .25 W CARBON FILM
0079A			R9
0080	00004.000	0972946-0041	RES FIX 100 OHM 5 % .25 W CARBON FILM
0080A			R13,R104,R138,R255
0081	00001.000	0972946-0043	RES FIX 120 OHM 5 % .25 W CARBON FILM
0081A			R19
0082	00001.000	0972946-0045	RES FIX 150 OHM 5 % .25 W CARBON FILM
0082A			R268
0083	00001.000	0972946-0047	RES FIX 180 OHM 5 % .25 W CARBON FILM
0083A			R8
0084	00001.000	0972946-0050	RES FIX 240 OHM 5 % .25 W CARBON FILM
0084A			R16
0085	00001.000	0972946-0051	RES FIX 270 OHM 5 % .25 W CARBON FILM
0085A			R208
0086	00003.000	0972946-0053	RES FIX 330 OHM 5 % .25 W CARBON FILM
0086A			R23 R120 R121
0087	00006.000	0972946-0057	RES FIX 470 OHM 5 % .25 W CARBON FILM
0087A			R14,R15,R17,R18,R250,R261
0088	00001.000	0972946-0058	RES FIX 510 OHM 5 % .25 W CARBON FILM
0088A			R26
0089	00001.000	0972946-0059	RES FIX 560 OHM 5 % .25 W CARBON FILM
0089A			R269
0090	00005.000	0972946-0065	RES FIX 1.0K OHM 5% .25 W CARBON FILM
0090A			R10,R12,R28,R110,R126
0091	00011.000	0972946-0072	RES FIX 2.0K OHM 5 % .25 W CARBON FILM
0091A			R1-R7,R11,R112,R127,R228
0092	00003.000	0972946-0077	RES FIX 3.3K OHM 5 % .25 W CARBON FILM

LIST OF MATERIALS

DATE 8/20/79
P/N 999947-0101

Terminal Electronics PWB

0101
REV P

PRINT ITEM NUMBER	QUANTITY PER ASSEMBLY	PART NUMBER	DESCRIPTION
0092A			R134,R206,R210
0093	00002.000	0972946-0081	RES FIX 4.7K OHM 5% .25 W CARBON FILM
0093A			R200,R254
0094	00007.000	0972946-0085	RES FIX 6.8K OHM 5% .25 W CARBON FILM
0094A			R20 R24 R29 R34 R35 R37
00948			R209
0095	00002.000	0972946-0089	RES FIX 10K OHM 5% .25 W CARBON FILM
0095A			R213,R264
0096	00001.000	0972946-0093	RES FIX 15K OHM 5% .25 W CARBON FILM
0096A			R216
0097	00001.000	0972946-0109	RES FIX 68 K OHM 5% .25 W CARBON FILM
0097A			R203
0098	00001.000	0972946-0117	RES FIX 150K OHM 5% .25 W CARBON FILM
0098A			R25
0099	00002.000	0972946-0137	RES FIX 1.0M OHM 5% .25 W CARBON FILM
0099A			R109,R128
0100	00001.000	0972946-0139	RES FIX 1.2M OHM 5% .25 W CARBON FILM
0100A			R220
0101	00001.000	0972946-0145	RES FIX 2.2M OHM 5% .25 W CARBON FILM
0101A			R218
0102	00001.000	0972947-0149	RES,FXD,FILM,INSUL, 1/2W, 3.3 MEG OHMS
0102A			R140
0103	00003.000	0972947-0031	RES FIX 39 OHM 5% .5 W CARBON FILM
0103A			R111,R118,R119
0104	00005.000	0972947-0053	RES FIX 330 OHM 5% .5 W CARBON FILM
0104A			R101,R113,R116,R132,R135
0105	00002.000	0972947-0102	RES FIX 36 K OHM 5% .5 W CARBON FILM
0105A			R262,R266
0106	00001.000	0972947-0089	RES FIX 10 K OHM 5% .5 W CARBON FILM
0106A			R253
0107	00001.000	0972947-0137	RES FIX 1.0M OHM 5% .5 W CARBON FILM
0107A			R229
0108	00001.000	0972554-0001	RESISTOR, FIXED, WIREWOUND .1 OHM 5W 5%
0108A			R102
0109	00001.000	0972947-0109	RES FIX 68 K OHM 5% .5 W CARBON FILM
0109A			R263
0111	00002.000	0972554-0011	RESISTOR, .25 OHM 3W 1% FX WW
0111A			R125,R133

LIST OF MATERIALS

DATE 8/20/79
P/N 999947-0101

Terminal Electronics PWB

0101
REV P

PRINT ITEM NUMBER	QUANTITY PER ASSEMBLY	PART NUMBER	DESCRIPTION
0112	00001.000	0972947-0055	RES FIX 390 OHM 5% .5 W CARBON FILM
0112A			R207
0113	00001.000	0972978-0149	RESISTOR,.10 MEG OHM 1W 5% FIXED CMPSM
0113A			R257
0114	00001.000	0972947-0072	RES FIX 2.0K OHM 5% .5 W CARBON FILM
0114A			R252
0115	00001.000	0972947-0038	RES FIX 75 OHM 5% .5 W CARBON FILM
0115A			R231
0116	00002.000	0972947-0065	RES FIX 1.0K OHM 5% .5 W CARBON FILM
0116A			R232,R233
0117	00001.000	0972947-0079	RES FIX 3.9K OHM 5% .5 W CARBON FILM
0117A			R226
0118	00001.000	0972055-0003	RESISTOR,600 OHM 25W NON-INDUCTIVE WW
0118A			R267
0119	00001.000	0972942-0191	RESISTOR,12.7K OHMS 5W 5% WW PWR
0119A			R270
0120	00001.000	0972942-0190	RESISTOR,.5 OHM 5W 5% FX,WW PWR
0120A			R251
0121	00002.000	0539370-0440	RES FIX FILM 3.74K OHM 1% .25 WATT
0121A			R36,R259
0122	00001.000	0539370-0405	RES FIX FILM 1.62K OHM 1% .25 WATT
0122A			R221
0123	00001.000	0539370-0410	RES FIX FILM 1.82K OHM 1% .25 WATT
0123A			R222
0124	00001.000	0539370-0477	RES FIX FILM 9.09K OHM 1% .25 WATT
0124A			R205
0125	00001.000	0539370-0479	RES FIX FILM 9.53K OHM 1% .25 WATT
0125A			R204
0126	00001.000	0539370-0460	RES FIX FILM 6.04K OHM 1% .25 WATT
0126A			R137
0127	00001.000	0539370-0504	RES FIX FILM 17.4K OHM 1% .25 WATT
0127A			R139
0128	00006.000	0539370-0481	RES FIX FILM 10.0K OHM 1% .25 WATT
0128A			R107,R114,R141-R143,R230
0129	00001.000	0539370-0558	RES FIX FILM 63.4K OHM 1% .25 WATT
0129A			R122
0130	00001.000	0539370-0512	RES FIX FILM 21.0K OHM 1% .25 WATT
0130A			R106

LIST OF MATERIALS

DATE 8/20/79
P/N 999947-0101

Terminal Electronics PWB

0101
REV P

PRINT ITEM NUMBER	QUANTITY PER ASSEMBLY	PART NUMBER	DESCRIPTION
0131	00002.000	0539370-0514	RES FIX FILM 22.1K OHM 1% .25 WATT
0131A			R105,R108
0132	00001.000	0539370-0577	RES FIX FILM 100 K OHM 1% .25 WATT
0132A			R202
0133	00003.000	0539370-0510	RES FIX FILM 20.0K OHM 1% .25 WATT
0133A			R115,R117,R260
0134	00001.000	0539370-0502	RES FIX FILM 16.5K OHM 1% .25 WATT
0134A			R256
0135	00001.000	0539370-0539	RES FIX FILM 40.2K OHM 1% .25 WATT
0135A			R123
0136	00001.000	0539370-0450	RES FIX FILM 4.75K OHM 1% .25 WATT
0136A			R225
0137	00001.000	0539370-0467	RES FIX FILM 7.15K OHM 1% .25 WATT
0137A			R219
0138	00001.000	0539370-0469	RES FIX FILM 7.50K OHM 1% .25 WATT
0138A			R103
0139	00001.000	0532439-0399	RESISTOR,1.40K OHMS 1% 1W WM FIXED
0139A			R215
0140	00001.000	0539812-0064	RESISTOR,8.25K OHM 1/8W .1% FX FILM
0140A			R130
0141	00001.000	0539812-0001	RES FIX FILM 4.12K OHM .1% .125 WATT
0141A			R224
0142	00004.000	0539812-0057	RES FIXED 10K OHMS .1%
0142A			R129,R131,R214,R223
0143	00001.000	0539812-0066	RES, 11.3K OHMS 1/8W,.1% FXD FILM
0143A			R124
0145	00001.000	0538425-0119	RESISTOR,22K OHMS 2W 5% FIXED CHPSN
0145A			R258
0146	00001.000	0538425-0123	RES 33000. OHM 5% 2WATT FIX COMP
0146A			R265
0147	00022.000	0972763-0021	CAP.,FIXED,AXIAL LEAD,.047 UF,+80%,-20%
0147A			C1-C6,C11-C14,C16-21,C23,
0147B			C102,C103,C106,C107,C215
0149	00001.000	0972929-0361	CAP FIX CERAMIC 10.0 PF 10 % 200 V
0149A			C8
0150	00002.000	0972929-0367	CAP FIX CERAMIC 22.0 PF 10 % 200 V
0150A			C9,C10
0151	00001.000	0972929-0376	CAP FIX CERAMIC 68.0 PF 10 % 200 V

LIST OF MATERIALS

DATE 8/20/79
P/N 999947-0101

Terminal Electronics PWB

0101
REV P

PRINT ITEM NUMBER	QUANTITY PER ASSEMBLY	PART NUMBER	DESCRIPTION
0151A			C22
0152	00001.000	0972929-0391	CAP FIX CERAMIC 470 PF 10 % 200 V
0152A			C7
0153	00003.000	0972929-0403	CAP .0022 UF 10% 100V
0153A			C15,C108,C200
0154	00001.000	0410529-0203	CAP FIX CERAMIC .02UF +80%-20% 600 V
0154A			C264
0155	00001.000	0972924-0007	CAP FIX TANT SOLID 120 MFD 10 % 10 VOLT
0155A			C261
0156	00001.000	0972924-0013	CAP FIX TANT SOLID 2.2 MFD 10 % 20 VOLT
0156A			C263
0157	00003.000	0972924-0014	CAP FIX TANT SOLID 15 MFD 10 % 20 VOLT
0157A			C206,C207,C251
0158	00001.000	0972924-0017	CAP FIX TANT SOLID 1.0 MFD 10 % 35 VOLT
0158A			C202
0159	00001.000	0058023-0016	CAP FIX .100 MFD 5 % 100V MYLAR FOIL
0159A			C104
0160	00001.000	0972928-0011	CAP FIX MICA 500V 3000 PF 5 %
0160A			C256
0161	00001.000	0972757-0003	CAP, FIXED CERAMIC 150 PF 10% 50V
0161A			C105
0162	00004.000	0412645-0015	CAPACITOR, .1 UF +80,-20% 500VDC CER DIELECT
0162A			C208-C210,C257
0163	00002.000	0972929-0415	CAP FIX CERAMIC .010 UF 10 % 100 V
0163A			C201,C253
0164	00002.000	0972927-0020	CAP FIX MICA 500V 51.0 PF 5 %
0164A			C252,C255
0165	00002.000	0972929-0433	CAP FIX CERAMIC .100 UF 10 % 50 V
0165A			C250,C260
0166	00001.000	0996810-0007	CAPACITOR, 3900PF 400V 20% CER, DIN TYPE
0166A			C262
0167	00001.000	0410529-0103	CAP FIX CERAMIC .010 MF GMV 1 KV
0167A			C254
0168	00001.000	0972965-0024	CAP FIX CERAMIC .100 MF 10% 100V
0168A			C101
0169	00002.000	0972601-0004	CAPACITOR, 330UF 200V 10% ALUM ELECTLY
0169A			C258,C259
0170	00001.000	0972931-0024	CAP, FIXED 14000MFD 7.5V 10%

LIST OF MATERIALS

DATE 8/20/79
P/N 999947-0101

Terminal Electronics PWB

0101
REV P

PRINT ITEM NUMBER	QUANTITY PER ASSEMBLY	PART NUMBER	DESCRIPTION
0170A			C205
0171	00002.000	0972931-0049	CAP,FXD,ELCTLT,AL,1800 MFD,20V,10%+/-75%
0171A			C211,C212
0172	00002.000	0972931-0084	CAPACITOR,2300UF 40V FX ELCTLT ALUM
0172A			C203,C204
0173	00001.000	2210188-0002	SOCKET,LOW PROFILE,DIP, 14 PINS
0173A			TP7
0174	00003.000	2210188-0005	SOCKET, LOW PROFILE, DIP, 20 PINS
0174A			XU23,XU24,XU45
0175	00006.000	2210188-0007	SOCKET, LOW PROFILE, DIP, 24 PINS
0175A			XU2,XU3,XU9-XU12
0176	00002.000	2210188-0008	SOCKET,LOW PROFILE,DIP,28 CONT
0176A			XU21,XU22
0177	00002.000	2210188-0009	SOCKET, LOW PROFILE, DIP, 40 PINS
0177A			XU20,XU32
0178	00001.000	0983910-0001	SUPPORT,TONE GENERATOR
0179	00001.000	0537399-0012	FUSE 5AMP .014 OHM
0179A			F200
0180	00003.000	0537399-0010	FUSE 3AMP
0180A			F101,F102,F103
0181	00001.000	0416434-0303	FUSE 3.0 A 250V 3AG
0181A			F250
0182	00002.000	0772635-0001	CLIP,FUSE
0183	00003.000	0972808-0001	THERMISTOR, DISC, 5 OHM
0183A			R271,R272,R273
0184	00001.000	0996865-0005	HEADER ASSY,9 POS RIGHT ANGLE,.100
0184A			J103
0185	00002.000	0972519-0023	SOCKET,SINGLE-IN-LINE 12 POS(GOLD CONT)
0185A			J10
0186	00001.000	0983836-0003	CABLE,HEATSINK GROUND,BLK/WHT,4.20"
0187	00002.000	0983836-0002	CABLE,HEATSINK GROUND,GRN/YEL,4.20"
0188	00001.000	0999869-0001	CABLE ASSY,SIGNAL/CHASSIS,GROUND-OPTION
0189	00145.000	0972456-0002	PIN,.025 SQUARE
0189A			E3 THRU E7,E15,E16
0189B			E205 THRU E216,E219,E220,
0189C			E234,E235,E262 THRU E265,
0189D			J3-1 THRU J3-6,
0189E			J3-8 THRU J3-24,

LIST OF MATERIALS

DATE 8/20/79
P/N 999947-0101

Terminal Electronics PWB

0101
REV P

PRINT ITEM NUMBER	QUANTITY PER ASSEMBLY	PART NUMBER	DESCRIPTION
0189F			J6-1 THRU J6-4, J6-6,
0189G			J8-1, J8-3 THRU J8-8,
0189H			J9-1, J9-2, J9-4,
0189I			J11-1 THRU J11-7,
0189J			J11-9 THRU J11-15, J11-18,
0189K			J12-1 THRU J12-3,
0189L			J12-5 THRU J12-28,
0189M			J13-1 THRU J13-7,
0189N			J13-9 THRU J13-15, J13-18,
0189P			J101-2 THRU J101-10,
0189Q			J104-1 THRU J104-4,
0189R			J105-1, J105-2, J105-4,
0189S			J106-1, J106-3 THRU J106-5,
0189T			J203-1, J203-2, J203-4
0190	00000.000	0972494-0001	PIN, .025 SQUARE
0191	00005.000	0996706-0002	POST, .715LG PRINTED CIRCUIT
0191A			E221-E223, E271, E281
0192	00013.000	0972487-0001	JUMPER PLUG, CONNECTOR BLACK
0193	00018.000	0996521-0018	INSULATOR, THERMALLY CONDUCTIVE, .800 W
0194	00001.000	0800482-0003	HEATSINK, TO-3 ALUM
0195	00001.000	0999802-0001	HEATSINK, POWER SUPPLY
0196	00001.000	0999803-0001	HEATSINK, CARRIAGE DRIVER
0197	00001.000	0999804-0001	HEATSINK, PAPER DRIVER
0198	00001.000	0999863-0001	HEATSINK, PRINTHEAD/RIBBON DRIVE MOTOR
0199	00001.000	0232583-0008	TO-5 MOUNTING PAD, 4-LEADS, NYLON
0200	AR	0417559-0001	SILICONE RUBBER (RTV) DOW 3140
0201	AR	0417200-0004	PRIMER, SILICONE RUBBER-RED
0202	AR	0415886-0001	GREASE, SILICONE, HEAT COND. (8 OZ TUBE)
0204	00001.000	0972306-0003	COVER, RND-1.807LG .019THK ALUM, SEAMLESS
0205	00001.000	0972621-0001	SPRING, RING
0206	00004.000	0972355-0006	STUD, SELF-CLINCHING 4-40 X .750LG PWB
0207	00001.000	0418801-0004	CRYSTAL, QUARTZ 4.000 MHZ HC-18/U
0207A			Y1
0208	00002.000	2210323-0001	BUS BAR, PCB, 311.40MM (12.26 IN.)
0209	00001.000	0972461-0001	DISC, SOUND-PIEZO-ELECT 3200 +/- 600 HZ
0209A			DS1
0210	00003.000	0972908-0013	SCREW 4-40 X .250 PAN HEAD CRES
0211	00015.000	0972988-0016	SCREW 4-40 X .438 PAN HEAD CRES

LIST OF MATERIALS

DATE 8/20/79
P/N 999947-0101

Terminal Electronics PWB

0101
REV P

PRINT ITEM NUMBER	QUANTITY PER ASSEMBLY	PART NUMBER	DESCRIPTION
0212	00001.000	0972988-0023	SCREW 4-40 X 1.50 PAN HEAD CRES
0213	00001.000	0972988-0014	SCREW 4-40 X .312 PAN HEAD CRES
0214	00024.000	0416453-0021	NUT, PLAIN, 4-40 UNC-2B HEX, CRES, SMALL
0215	00032.000	0411027-0803	WASHER .125 X .250 X .022 FLAT CRES
0216	00002.000	0416622-0011	WASHER #4 FLAT
0217	00019.000	0411104-0135	WASHER, LOCK-SPRING, HELICAL, #4
0218	00005.000	0411101-0057	LOCKWASHER # 4 EXTERNAL TOOTH CRES
0219	00019.000	0972628-0001	WASHER, #4 .115ID .2000D-SHLDR NON-MET
0220	00002.000	0416925-0600	SPACERS-SCREW & BOLT #6 1/4 X .049
0221	00001.000	0416925-0417	SPACERS-SCREW AND BOLT #4 3/16 X .028
0222	00002.000	0999862-0001	SPACER, POWER TRANSISTOR
0223	00000.200	0411400-0018	WIRE, BARE TINNED, 18AWG, COPPER BUS
0224	00000.500	0411400-0022	WIRE 22AWG ELETRO-TIN-PLATED, COPPER
0225	AR	2210083-0003	WIRE, ELEC, COND U/L STYLE 1213, 24 AWG
0226	00002.000	0418212-0040	STRAP, TIEDOWN, ADJUSTABLE, PLASTIC
0227	00000.050	0411634-1310	SLEEVE, PVC, .133 DIA. CLEAR
0231	00001.000	0999880-0001	BATTERY PACK
0232	00001.000	0996707-0002	THERMISTOR, DISC, 100 OHMS
0232A			R227
0233	00000.000	0996914-0001	CLIP, CARTRIDGE FUSE .25 DIA.
0233A			ITEM 233 MAY BE SUSTITUTED
0233B			AS AN ALTERNATE FOR ITEM
0233C			182
0234	00000.000	2210422-0001	IC, TRANSCEIVER, BUS, OCTAL
0234A			ITEM 234 MAY BE SUBSTITUTED
0234B			FOR ITEM 37. IF ITEM 234 IS
0234C			USED, IT IS TO BE INSTALLED
0234D			IN LOCATION U31A
0235	REF	0994396-9901	PROCEDURE, SITE & DATE CODE SERIALIZATION
0236	00001.000	0185113-0001	X SPACER XST TO-18 CASE

LIST OF MATERIALS

Terminal Electronics PWB

DATE 8/20/79
P/N 999947-0201

0201
REV P

PRINT ITEM NUMBER	QUANTITY PER ASSEMBLY	PART NUMBER	DESCRIPTION
0001	00001.000	0999946-0001	PWB, TERMINAL ELECTRONICS
0002	REF	0999945-0001	DIAG, LOGIC, DETAILED TERMINAL ELECT
0003	00001.000	0222224-2741	NETWORK SN72741P OPERATIONAL AMP
0003A			U202
0004	00001.000	0972499-0002	NETWORK, VOLG REG, NEG, 3 TERM-(-12V)
0004A			U206
0005	00001.000	0972872-0012	NETWORK, LM 340-12T VOLTAGE REGULATOR
0005A			U205
0006	00001.000	0972663-0001	NETWORK, LM339N
0006A			U203
0007	00002.000	0996709-0001	IC, LM393P DIFFERENTIAL COMPARATOR
0007A			U107, U113
0008	00001.000	0996594-0001	ISOLATOR, OPTICALLY COUPLED
0008A			U201
0009	00000.000	2210036-0001	IC, OPTICALLY COUPLED ISOLATOR
0009A			U201, ITEM 9 MAY BE
0009B			SUBSTITUTED AS AN ALTERNATE
0009C			FOR ITEM 8
0010	00003.000	0996727-0002	IC, ULN2065B, DARLINGTON QUAD
0010A			U101, U102, U103
0012	00002.000	0972141-0031	NETWORK, RES. 390 OHM 2 X 14 PIN DIP
0012A			U106, U109
0013	00001.000	0800118-0015	RESISTOR 6.8KOHMS DIL PULL UP 16 PINS
0013A			U38
0014	00001.000	0972037-1910	NETWORK, RES 16 PIN 8 ELEM- 91.00 OHMS
0014A			U14
0015	00001.000	2210301-0001	IC, MICROPROCESSOR, CPU
0015A			U20
0016	00001.000	2210307-0004	IC, (USART) SERIAL I/O, SIO/9 CHAN A ONLY
0016A			U32
0017	00000.000	2210307-0001	IC, (USART) SERIAL I/O, SIO/0 BONDING
0017A			U32, ITEM 17 MAY BE
0017B			SUBSTITUTED AS AN ALTERNATE
0017C			FOR ITEM 16
0018	00000.000	2210307-0002	IC, (USART) SERIAL I/O, SIO/1 BONDING
0018A			U32, ITEM 18 MAY BE
0018B			SUBSTITUTED AS AN ALTERNATE
0018C			FOR ITEM 16

LIST OF MATERIALS

DATE 8/20/79
P/N 999947-0201

Terminal Electronics PWB

0201
REV P

PRINT ITEM NUMBER	QUANTITY PER ASSEMBLY	PART NUMBER	DESCRIPTION
0019	00000.000	2210307-0003	IC,(USART) SERIAL I/O,SIO/2 BONDING
0019A			U32,ITEM 19 MAY BE
0019B			SUBSTITUTED AS AN ALTERNATE
0019C			FOR ITEM 16
0020	00002.000	2210302-0001	IC, COUNTER TIMER CKT,28 PIN CERAMIC PKG
0020A			U21,U22
0021	00001.000	0996750-0001	IC,TMS-4732NLZA3226,4096 X 8-BIT PREPGM
0021A			U11
0022	00001.000	2207625-0003	IC,8K X 8 ROM 820 TERMINAL
0022A			U9
0023	00001.000	2207625-0004	IC,8K X 8 ROM 820 TERMINAL
0023A			U10
0024	00002.000	0996203-0002	IC,S 5101L-1 1024BIT(256 X 4)ST CMOS RAM
0024A			U4,U5
0025	00002.000	2210363-0001	IC, 1K X 8-BIT RAM, 24-PIN,DUAL-IN-LINE
0025A			U2,U3
0026	00001.000	0972900-7402	NETWORK SN74LS02N
0026A			U110
0027	00001.000	0972900-7404	NETWORK SN74LS04N
0027A			U19
0028	00001.000	0222222-7406	NETWORK SN7406N
0028A			U28
0029	00001.000	0972749-0001	NETWORK, SN74LS08N
0029A			U16
0030	00001.000	0972784-0002	NETWORK SN74LS14N
0030A			U1
0031	00004.000	0222222-7417	NETWORK-SN7417N
0031A			U104,U105,U108,U112
0032	00001.000	0972900-7109	NETWORK SN74LS109N
0032A			U40
0033	00001.000	0996399-0001	IC,SN74LS107N DUAL-NEGATIVE-EDGE
0033A			U30
0034	00002.000	0972900-7138	NETWORK SN74LS138N
0034A			U25,U26
0035	00001.000	0972686-0001	NETWORK-QUAD MULTIPLEXER, SN74LS157N
0035A			U35
0036	00004.000	0996089-0004	IC,SN74LS244N LINE DRIVER
0036A			U17,U29,U33,U34

LIST OF MATERIALS

DATE 8/20/79
P/N 999947-0201

Terminal Electronics PWB

0201
REV P

PRINT ITEM NUMBER	QUANTITY PER ASSEMBLY	PART NUMBER	DESCRIPTION
0037	00001.000	0996755-0001	IC,SN74LS245N BUS XCVR TRANSITION
0037A			U31
0038	00002.000	0972120-0001	NETWORK,SN74259 8-BIT ADDRESSABLE LATCH
0038A			U18,U6
0039	00005.000	0996029-0001	IC,SN74LS273N OCTAL D-TYPE FLIP/FLOP
0039A			U7,U15,U27,U36,U37
0040	00002.000	0996015-0001	IC,QUAD LINE DRIVERS SN75188N
0040A			U41,U42
0041	00002.000	0972450-0002	NETWORK,SN75189AN/MC1489AL QUAD LINE RCR
0041A			U43,U44
0042	00001.000	2206549-0001	PROM,PROGRAMMED,TACH PHASE DECODE
0042A			U8
0043	00001.000	2206550-0001	PROM,PROGRAMMED,MEMORY SELECT DECODE
0043A			U13
0044	00005.000	0972932-0001	SEMICONDUCTOR DEVICE, DIODE, IN9148
0044A			CR2,CR112,CR113,CR210,CR256
0045	00031.000	0539468-0002	DIODE,IN4002 1AMP 100PIV RECTIFIER
0045A			CR3,CR101-CR111,CR123-
0045B			CR132,CR135-CR138,CR204,
0045C			CR250-CR252,CR254
0046	00001.000	0539468-0007	DIODE,IN4007 1AMP 1000PIV RECTIFIER
0046A			CR258
0047	00001.000	0972116-0001	X DIODE UTG1249 (MAY USE IN5808/IN5809)
0047A			CR205
0048	00006.000	0996036-0003	DIODE,3 AMP 100V RECTIFIER
0048A			CR114,CR116,CR118-CR121
0049	00001.000	0972164-0001	DIODE,MR501
0049A			CR255
0050	00005.000	0972164-0006	DIODE,3 AMP 1,000V SILICONE
0050A			CR262-CR266
0051	00001.000	0803297-0001	DIODE,SCHOTTKY BARRIER,UHF MIXER
0051A			CR1
0052	00003.000	0972268-0006	DIODE IN4937 1 AMP
0052A			CR257,CR259,CR260
0053	00002.000	0972268-0002	DIODE IN4934-1 AMP
0053A			CR209,CR211
0054	00001.000	0996036-0004	DIODE,MR852 RECTIFIER SILICON FAST RCVV
0054A			CR203

LIST OF MATERIALS

DATE 8/20/79
P/N 999947-0201

Terminal Electronics PWB

0201
REV P

PRINT ITEM NUMBER	QUANTITY PER ASSEMBLY	PART NUMBER	DESCRIPTION
0055	00002.000	0972460-0007	DIODE, SILICON, ZENER 1X
0055A			CR201, CR202
0056	00002.000	0972460-0006	DIODE E7918, SILICON, ZENER-1X
0056A			CR115, CR122
0057	00001.000	0801295-0062	SEMICONDUCTOR DEVICE, DIODE IN5338B 5W
0057A			CR253
0058	00001.000	0972118-0001	DIODE, IN5339B
0058A			CR207
0059	00001.000	0972118-0005	SEMICONDUCTOR DEVICE, DIODE-IN5350B
0059A			CR206
0060	00004.000	0801295-0084	SEMICONDUCTOR DEVICE, DIODE IN5360B 5W
0060A			CR117, CR133, CR134, CR139
0061	00001.000	0996036-0006	DIODE, MR856 RECTIFIER SILICON FAST RCVY
0061A			CR261
0062	00008.000	0972057-0001	TRANSISTOR-A5T2222 NPN SILICON
0062A			Q2, Q3, Q6, Q103, Q104, Q107
0062B			Q202, Q252
0063	00003.000	0800523-0001	TRANSISTOR A5T2907 PNP SILICON
0063A			Q1, Q203, Q253
0064	00001.000	0772116-0003	TRANSISTOR, SYMM N-CHANNEL FET T1S73
0064A			Q201
0065	00001.000	0972542-0001	TRANSISTOR, HV PNP FN5416/S41802
0065A			Q251
0066	00004.000	0996712-0001	TRANSISTOR, TIP105 P-N-P POWER
0066A			Q101, Q108, Q109, Q113
0067	00006.000	0996801-0001	TRANSISTOR, TIP100 N-P-N, DARLINGTON
0067A			Q110, Q111, Q114-Q117
0068	00005.000	0996711-0002	TRANSISTOR, TIP73A N-P-N POWER
0068A			Q102, Q105, Q106, Q119, Q254
0069	00001.000	0972955-0001	XSTR 2N2369A, NPN, HIGH SPEED SW, TO-18
0069A			Q5
0070	00001.000	0996703-0001	TRANSISTOR, 2N6545 NPN, 125 WATT POWER
0070A			Q250
0071	00001.000	0800257-0001	TRANSISTOR
0071A			Q4
0072	00001.000	0972465-0003	THYRISTORS, TRIODE-P-N-P-N SIL
0072A			Q255
0073	00001.000	0999789-0001	TRANSFORMER, SWITCH MODE, 820 PWR SUPPLY

LIST OF MATERIALS

DATE 8/20/79
P/N 999947-0201

Terminal Electronics PWB

0201
REV P

PRINT ITEM NUMBER	QUANTITY PER ASSEMBLY	PART NUMBER	DESCRIPTION
0073A			T201
0074	00001.000	0996873-0001	TOROID CORE
0074A			T250
0075	00002.000	0972946-0025	RES FIX 22.0 OHM 5 % .25 W-CARBON FILM
0075A			R21,R22
0076	00001.000	0972946-0031	RES FIX 39.0 OHM 5 % .25 W-CARBON FILM
0076A			R27
0077	00001.000	0972946-0129	RES FIX 470K OHM 5 % .25 W CARBON FILM
0077A			R217
0078	00004.000	0972946-0037	RES FIX 68.0 OHM 5 % .25 W-CARBON FILM
0078A			R30-R33
0079	00001.000	0972946-0038	RES FIX 75.0 OHM 5 % .25 W-CARBON FILM
0079A			R9
0080	00004.000	0972946-0041	RES FIX 100 OHM 5 % .25 W CARBON FILM
0080A			R13,R104,R138,R255
0081	00001.000	0972946-0043	RES FIX 120 OHM 5 % .25 W CARBON FILM
0081A			R19
0082	00001.000	0972946-0045	RES FIX 150 OHM 5 % .25 W CARBON FILM
0082A			R268
0083	00001.000	0972946-0047	RES FIX 180 OHM 5 % .25 W CARBON FILM
0083A			R8
0084	00001.000	0972946-0050	RES FIX 240 OHM 5 % .25 W CARBON FILM
0084A			R16
0085	00001.000	0972946-0051	RES FIX 270 OHM 5 % .25 W CARBON FILM
0085A			R208
0086	00003.000	0972946-0053	RES FIX 330 OHM 5 % .25 W CARBON FILM
0086A			R23 R120 R121
0087	00006.000	0972946-0057	RES FIX 470 OHM 5 % .25 W CARBON FILM
0087A			R14,R15,R17,R18,R250,R261
0088	00001.000	0972946-0058	RES FIX 510 OHM 5 % .25 W CARBON FILM
0088A			R26
0089	00001.000	0972946-0059	RES FIX 560 OHM 5 % .25 W CARBON FILM
0089A			R269
0090	00005.000	0972946-0065	RES FIX 1.0K OHM 5% .25 W CARBON FILM
0090A			R10,R12,R28,R110,R126
0091	00011.000	0972946-0072	RES FIX 2.0K OHM 5 % .25 W CARBON FILM
0091A			R1-R7,R11,R112,R127,R228
0092	00003.000	0972946-0077	RES FIX 3.3K OHM 5 % .25 W CARBON FILM

LIST OF MATERIALS

DATE 8/20/79
P/N 999947-0201

Terminal Electronics PWB

0201
REV P

PRINT ITEM NUMBER	QUANTITY PER ASSEMBLY	PART NUMBER	DESCRIPTION
0092A			R134,R206,R210
0093	00002.000	0972946-0081	RES FIX 4.7K OHM 5 % .25 W CARBON FILM
0093A			R200,R254
0094	00007.000	0972946-0085	RES FIX 6.8K OHM 5 % .25 W CARBON FILM
0094A			R20 R24 R29 R34 R35 R37
0094B			R209
0095	00002.000	0972946-0089	RES FIX 10K OHM 5% .25 W CARBON FILM
0095A			R213,R264
0096	00001.000	0972946-0093	RES FIX 15K OHM 5% .25 W CARBON FILM
0096A			R216
0097	00001.000	0972946-0109	RES FIX 68 K OHM 5 % .25 W CARBON FILM
0097A			R203
0098	00001.000	0972946-0117	RES FIX 150K OHM 5 % .25 W CARBON FILM
0098A			R25
0099	00002.000	0972946-0137	RES FIX 1.0M OHM 5 % .25 W CARBON FILM
0099A			R109,R128
0100	00001.000	0972946-0139	RES FIX 1.2M OHM 5 % .25 W CARBON FILM
0100A			R220
0101	00001.000	0972946-0145	RES FIX 2.2M OHM 5 % .25 W CARBON FILM
0101A			R218
0102	00001.000	0972947-0149	RES,FXD,FILM,INSUL, 1/2W, 3.3 MEG OHMS
0102A			R140
0103	00003.000	0972947-0031	RES FIX 39 OHM 5 % .5 W CARBON FILM
0103A			R111,R118,R119
0104	00005.000	0972947-0053	RES FIX 330 OHM 5% .5 W CARBON FILM
0104A			R101,R113,R116,R132,R135
0105	00002.000	0972947-0102	RES FIX 36 K OHM 5% .5 W CARBON FILM
0105A			R262,R266
0106	00001.000	0972947-0089	RES FIX 10 K OHM 5% .5 W CARBON FILM
0106A			R253
0107	00001.000	0972947-0137	RES FIX 1.0M OHM 5% .5 W CARBON FILM
0107A			R229
0108	00001.000	0972554-0001	RESISTOR,FIXED,WIREWOUND.1 OHM 5W 5%
0108A			R102
0109	00001.000	0972947-0109	RES FIX 68 K OHM 5% .5 W CARBON FILM
0109A			R263
0111	00002.000	0972554-0011	RESISTOR,.25 OHM 3W 1% FX WW
0111A			R125,R133

LIST OF MATERIALS

DATE 8/20/79
P/N 999947-0201

Terminal Electronics PWB

0201
REV P

PRINT ITEM NUMBER	QUANTITY PER ASSEMBLY	PART NUMBER	DESCRIPTION
0112	00001.000	0972947-0055	RES FIX 390 OHM 5% .5 W CARBON FILM
0112A			R207
0113	00001.000	0972978-0149	RESISTOR,.10 MEG OHM 1W 5% FIXED CNPSM
0113A			R257
0114	00001.000	0972947-0072	RES FIX 2.0K OHM 5% .5 W CARBON FILM
0114A			R252
0115	00001.000	0972947-0038	RES FIX 75 OHM 5% .5 W CARBON FILM
0115A			R231
0116	00002.000	0972947-0065	RES FIX 1.0K OHM 5% .5 W CARBON FILM
0116A			R232,R233
0117	00001.000	0972947-0079	RES FIX 3.9K OHM 5% .5 W CARBON FILM
0117A			R226
0118	00001.000	0972055-0003	RESISTOR,.600 OHM 25W NON-INDUCTIVE WW
0118A			R267
0119	00001.000	0972942-0191	RESISTOR,12.7K OHMS 5W 5% WW PWR
0119A			R270
0120	00001.000	0972942-0190	RESISTOR,.5 OHM 5W 5% FX,WW PWR
0120A			R251
0121	00002.000	0539370-0440	RES FIX FILM 3.74K OHM 1% .25 WATT
0121A			R36,R259
0122	00001.000	0539370-0405	RES FIX FILM 1.62K OHM 1% .25 WATT
0122A			R221
0123	00001.000	0539370-0410	RES FIX FILM 1.82K OHM 1% .25 WATT
0123A			R222
0124	00001.000	0539370-0477	RES FIX FILM 9.09K OHM 1% .25 WATT
0124A			R205
0125	00001.000	0539370-0479	RES FIX FILM 9.53K OHM 1% .25 WATT
0125A			R204
0126	00001.000	0539370-0460	RES FIX FILM 6.04K OHM 1% .25 WATT
0126A			R137
0127	00001.000	0539370-0504	RES FIX FILM 17.4K OHM 1% .25 WATT
0127A			R139
0128	00006.000	0539370-0481	RES FIX FILM 10.0K OHM 1% .25 WATT
0128A			R107,R114,R141-R143,R230
0129	00001.000	0539370-0558	RES FIX FILM 63.4K OHM 1% .25 WATT
0129A			R122
0130	00001.000	0539370-0512	RES FIX FILM 21.0K OHM 1% .25 WATT
0130A			R106

LIST OF MATERIALS

DATE 8/20/79
P/N 999947-0201

Terminal Electronics PWB

0201
REV P

PRINT ITEM NUMBER	QUANTITY PER ASSEMBLY	PART NUMBER	DESCRIPTION
0131	00002.000	0539370-0514	RES FIX FILM 22.1K OHM 1% .25 WATT
0131A			R105,R108
0132	00001.000	0539370-0577	RES FIX FILM 100 K OHM 1% .25 WATT
0132A			R202
0133	00003.000	0539370-0510	RES FIX FILM 20.0K OHM 1% .25 WATT
0133A			R115,R117,R260
0134	00001.000	0539370-0502	RES FIX FILM 16.5K OHM 1% .25 WATT
0134A			R256
0135	00001.000	0539370-0539	RES FIX FILM 40.2K OHM 1% .25 WATT
0135A			R123
0136	00001.000	0539370-0450	RES FIX FILM 4.75K OHM 1% .25 WATT
0136A			R225
0137	00001.000	0539370-0467	RES FIX FILM 7.15K OHM 1% .25 WATT
0137A			R219
0138	00001.000	0539370-0469	RES FIX FILM 7.50K OHM 1% .25 WATT
0138A			R103
0139	00001.000	0532439-0399	RESISTOR,1.40K OHMS 1% 1W WW FIXED
0139A			R215
0140	00001.000	0539812-0064	RESISTOR,8.25K OHM 1/8W .1% FX FILM
0140A			R130
0141	00001.000	0539812-0001	RES FIX FILM 4.12K OHM .1% .125 WATT
0141A			R224
0142	00004.000	0539812-0057	RES FIXED 10K OHMS .1%
0142A			R129,R131,R214,R223
0143	00001.000	0539812-0066	RES, 11.3K OHMS 1/8W,.1% FXD FILM
0143A			R124
0145	00001.000	0538425-0119	RESISTOR,22K OHMS 2W 5% FIXED CMPSN
0145A			R258
0146	00001.000	0538425-0123	RES 33000. OHM 5% 2WATT FIX COMP
0146A			R265
0147	00022.000	0972763-0021	CAP.,FIXED,AXIAL LEAD,.047 UF,+80%,-20%
0147A			C1-C6,C11-C14,C16-C21,C23,
0147B			C102,C103,C106,C107,C215
0149	00001.000	0972929-0361	CAP FIX CERAMIC 10.0 PF 10 % 200 V
0149A			C8
0150	00002.000	0972929-0367	CAP FIX CERAMIC 22.0 PF 10 % 200 V
0150A			C9,C10
0151	00001.000	0972929-0376	CAP FIX CERAMIC 68.0 PF 10 % 200 V

LIST OF MATERIALS

DATE 8/20/79
P/N 999947-0201

Terminal Electronics PWB

REV 0201
P

PRINT ITEM NUMBER	QUANTITY PER ASSEMBLY	PART NUMBER	DESCRIPTION
0151A			C22
0152	00001.000	0972929-0391	CAP FIX CERAMIC 470 PF 10 % 200 V
0152A			C7
0153	00003.000	0972929-0403	CAP .0022 UF 10% 100V
0153A			C15,C108,C200
0154	00001.000	0410529-0203	CAP FIX CERAMIC .02UF +80%-20% 600 V
0154A			C264
0155	00001.000	0972924-0007	CAP FIX TANT SOLID 120 MFD 10 % 10 VOLT
0155A			C261
0156	00001.000	0972924-0013	CAP FIX TANT SOLID 2.2 MFD 10 % 20 VOLT
0156A			C263
0157	00003.000	0972924-0014	CAP FIX TANT SOLID 15 MFD 10 % 20 VOLT
0157A			C206,C207,C251
0158	00001.000	0972924-0017	CAP FIX TANT SOLID 1.0 MFD 10 % 35 VOLT
0158A			C202
0159	00001.000	0058023-0016	CAP FIX .100 MFD 5 % 100V MYLAR FOIL
0159A			C104
0160	00001.000	0972928-0011	CAP FIX MICA 500V 3000 PF 5 %
0160A			C256
0161	00001.000	0972757-0003	CAP, FIXED CERAMIC 150 PF 10% 50V
0161A			C105
0162	00004.000	0412645-0015	CAPACITOR, .1 UF +80,-20% 500VDC CER DIEL
0162A			C208-C210,C257
0163	00002.000	0972929-0415	CAP FIX CERAMIC .010 UF 10 % 100 V
0163A			C201,C253
0164	00002.000	0972927-0020	CAP FIX MICA 500V 51.0 PF 5 %
0164A			C252,C255
0165	00002.000	0972929-0433	CAP FIX CERAMIC .100 UF 10 % 50 V
0165A			C250,C260
0166	00001.000	0996810-0007	CAPACITOR, 3900PF 400V 20% CER, DIN TYPE
0166A			C262
0167	00001.000	0410529-0103	CAP FIX CERAMIC .010 MF GMV 1 KV
0167A			C254
0168	00001.000	0972965-0024	CAP FIX CERAMIC .100 MF 10% 100V
0168A			C101
0169	00002.000	0972601-0004	CAPACITOR .330UF 200V 10% ALUM ELECTLT
0169A			C258,C259
0170	00001.000	0972931-0024	CAP, FIXED 1400MFD 7.5V 10%

LIST OF MATERIALS

DATE 8/20/79
P/N 999947-0201

Terminal Electronics PWB

0201
REV P

PRINT ITEM NUMBER	QUANTITY PER ASSEMBLY	PART NUMBER	DESCRIPTION
0170A			C205
0171	00002.000	0972931-0049	CAP,FXD,ELCTLT,AL,1800 MFD,20V,10%/-75%
0171A			C211,C212
0172	00002.000	0972931-0084	CAPACITOR,2300UF 40V FX ELCTLT ALUM
0172A			C203,C204
0173	00001.000	2210188-0002	SOCKET,LOW PROFILE,DIP, 14 PINS
0173A			TP7
0174	00003.000	2210188-0005	SOCKET, LOW PROFILE, DIP, 20 PINS
0174A			XU23,XU24,XU45
0175	00006.000	2210188-0007	SOCKET, LOW PROFILE, DIP, 24 PINS
0175A			XU2,XU3,XU9-XU12
0176	00002.000	2210188-0008	SOCKET,LOW PROFILE,DIP,28 CONT
0176A			XU21,XU22
0177	00002.000	2210188-0009	SOCKET, LOW PROFILE, DIP, 40 PINS
0177A			XU20,XU32
0178	00001.000	0983910-0001	SUPPORT,TONE GENERATOR
0179	00001.000	0537399-0012	FUSE 5AMP .014 OHM
0179A			F200
0180	00003.000	0537399-0010	FUSE 3AMP
0180A			F101,F102,F103
0181	00001.000	0416434-0303	FUSE 3.0 A 250V 3AG
0181A			F250
0182	00002.000	0772635-0001	CLIP,FUSE
0183	00003.000	0972808-0001	THERMISTOR, DISC, 5 OHM
0183A			R271,R274,R275
0184	00001.000	0996865-0005	HEADER ASSY,9 POS RIGHT ANGLE,.100
0184A			J103
0185	00002.000	0972519-0023	SOCKET,SINGLE-IN-LINE 12 POS(GOLD CONT)
0185A			J10
0186	00001.000	0983836-0003	CABLE,HEATSINK GROUND,BLK/WHT,4.20"
0187	00002.000	0983836-0002	CABLE,HEATSINK GROUND,GRN/YEL,4.20"
0188	00001.000	0999869-0001	CABLE ASSY,SIGNAL/CHASSIS,GROUND-OPTION
0189	00145.000	0972456-0002	PIN,.025 SQUARE
0189A			E3 THRU E7,E15,E16
0189B			E205 THRU E216,E219,E220,
0189C			E234,E235,E262 THRU E265,
0189D			J3-1 THRU J3-6,
0189E			J3-8 THRU J3-24,

LIST OF MATERIALS

Terminal Electronics PWB

DATE 8/20/79
P/N 999947-0201

0201
REV P

PRINT ITEM NUMBER	QUANTITY PER ASSEMBLY	PART NUMBER	DESCRIPTION
0189F			J6-1 THRU J6-4, J6-6,
0189G			J8-1, J8-3 THRU J8-8,
0189H			J9-1, J9-2, J9-4,
0189I			J11-1 THRU J11-7,
0189J			J11-9 THRU J11-15, J11-18,
0189K			J12-1 THRU J12-3,
0189L			J12-5 THRU J12-28,
0189M			J13-1 THRU J13-7,
0189N			J13-9 THRU J13-15, J13-18,
0189P			J101-2 THRU J101-10,
0189Q			J104-1 THRU J104-4,
0189R			J105-1, J105-2, J105-4,
0189S			J106-1, J106-3 THRU J106-5,
0189T			J203-1, J203-2, J203-4
0190	00000.000	0972494-0001	PIN, .025 SQUARE
0191	00005.000	0996706-0002	POST, .715LG PRINTED CIRCUIT
0191A			E221-E223, E271, E281
0192	00013.000	0972487-0001	JUMPER PLUG, CONNECTOR BLACK
0193	00018.000	0996521-0018	INSULATOR, THERMALLY CONDUCTIVE, .800 W
0194	00001.000	0800482-0003	HEATSINK, TO-3 ALUM
0195	00001.000	0999802-0001	HEATSINK, POWER SUPPLY
0196	00001.000	0999803-0001	HEATSINK, CARRIAGE DRIVER
0197	00001.000	0999804-0001	HEATSINK, PAPER DRIVER
0198	00001.000	0999863-0001	HEATSINK, PRINTHEAD/RIBBON DRIVE MOTOR
0199	00001.000	0232583-0008	TO-5 MOUNTING PAD, 4-LEADS, NYLON
0200	AR	0417559-0001	SILICONE RUBBER (RTV) DOW 3140
0201	AR	0417200-0004	PRIMER, SILICONE RUBBER-RED
0202	AR	0415886-0001	GREASE, SILICONE, HEAT COND. (8 OZ TUBE)
0204	00001.000	0972306-0003	COVER, RND-1.807LG .019THK ALUM, SEAMLESS
0205	00001.000	0972621-0001	SPRING, RING
0206	00004.000	0972355-0006	STUD, SELF-CLINCHING 4-40 X .750LG PWB
0207	00001.000	0418801-0004	CRYSTAL, QUARTZ 4.000 MHZ HC-18/U
0207A			Y1
0208	00002.000	2210323-0001	BUS BAR, PCB, 311.40MM (12.26 IN.)
0209	00001.000	0972461-0001	DISC, SOUND-PIEZO-ELECT 3200 +/- 600 HZ
0209A			DS1
0210	00003.000	0972988-0013	SCREW 4-40 X .250 PAN HEAD CRES
0211	00015.000	0972988-0016	SCREW 4-40 X .438 PAN HEAD CRES

LIST OF MATERIALS

DATE 8/20/79
P/N 999947

Terminal Electronics PWB

000 0201
REV P

PRINT NUMBER	QUANTITY PER ASSEMBLY	PART NUMBER	DESCRIPTION
	00001.000	0972988-0023	SCREW 4-40 X 1.50 PAN HEAD CRES
	00001.000	0972988-0014	SCREW 4-40 X .312 PAN HEAD CRES
0214	00024.000	0416453-0021	NUT,PLAIN,4-40 UNC-2B HEX,CRES,SMALL
0215	00032.000	0411027-0803	WASHER .125 X .250 X .022 FLAT CRES
0216	00002.000	0416622-0011	WASHER #4 FLAT
0217	00019.000	0411104-0135	WASHER, LOCK-SPRING, HELICAL, #4
0218	00005.000	0411101-0057	LOCKWASHER # 4 EXTERNAL TOOTH CRES
0219	00019.000	0972628-0001	WASHER,#4 .115ID .2000D-SHLDR NON-MET
0220	00002.000	0416925-0600	SPACERS-SCREW & BOLT #6 1/4 X.049
0221	00001.000	0416925-0417	SPACERS-SCREW AND BOLT #4 3/16 X .028
0222	00002.000	0999862-0001	SPACER, POWER TRANSISTOR
0223	00000.200	0411400-0018	WIRE,BARE TINNED,18AWG, COPPER BUS
0224	00000.500	0411400-0022	WIRE 22AWG ELETRO-TIN-PLATED,COPPER
0225	AR	2210083-0003	WIRE,ELEC,COND U/L STYLE 1213,24 AWG
0226	00002.000	0418212-0040	STRAP,TIEDOWN,ADJUSTABLE,PLASTIC
0227	00000.050	0411634-1310	SLEEVE,PVC, .133 DIA. CLEAR
0231	00001.000	0999880-0001	BATTERY PACK
0232	00001.000	0996707-0002	THERMISTOR,DISC, 100 OHMS
0232A			R227
0233	00000.000	0996914-0001	CLIP,CARTRIDGE FUSE .25 DIA.
0233A			ITEM 233 MAY BE SUSTITUTED
0233B			AS AN ALTERNATE FOR ITEM
0233C			182
0234	00000.000	2210422-0001	IC,TRANSCIEVER,BUS, OCTAL
0234A			ITEM 234 MAY BE SUBSTITUTED
0234B			FOR ITEM 37. IF ITEM 234 IS
0234C			USED, IT IS TO BE INSTALLED
0234D			IN LOCATION U31A
0235	REF	0994396-9901	PROCEDURE,SITE & DATE CODE SERIALIZATION
0236	00001.000	0185113-0001	X SPACER XST TO-18 CASE

LIST OF MATERIALS

DATE 8/24/79
P/N 999947

Terminal Electronics PWB

0401
REV P

PRINT NUMBER	QUANTITY PER ASSEMBLY	PART NUMBER	DESCRIPTION
0001	00001.000	0999946-0001	PWB, TERMINAL ELECTRONICS
0002	REF	0999945-0001	DIAG, LOGIC, DETAILED TERMINAL ELECT
0003	00001.000	0222224-2741	NETWORK SN72741P OPERATIONAL AMP
0003A			U202
0004	00001.000	0972499-0002	NETWORK, VOLG REG, NEG, 3 TERM-(-12V)
0004A			U206
0005	00001.000	0972872-0012	NETWORK, LM 340-12T VOLTAGE REGULATOR
0005A			U205
0006	00001.000	0972663-0001	NETWORK, LM339N
0006A			U203
0007	00002.000	0996709-0001	IC, LM393P DIFFERENTIAL COMPARATOR
0007A			U107, U113
0008	00001.000	0996594-0001	ISOLATOR, OPTICALLY COUPLED
0008A			U201
0009	00000.000	2210036-0001	IC, OPTICALLY COUPLED ISOLATOR
0009A			U201, ITEM 9 MAY BE
0009B			SUBSTITUTED AS AN ALTERNATE
0009C			FOR ITEM 8
0010	00003.000	0996727-0002	IC, ULN2065B, DARLINGTON QUAD
0010A			U101, U102, U103
0012	00002.000	0972141-0031	NETWORK, RES. 390 OHM 2 % 14 PIN DIP
0012A			U106, U109
0013	00001.000	0800118-0015	RESISTOR 6.8KOHMS DIL PULL UP 16 PINS
0013A			U38
0014	00001.000	0972037-1910	NETWORK, RES 16 PIN 8 ELEM- 91.00 OHM
0014A			U14
0015	00001.000	2210301-0001	IC, MICROPROCESSOR, CPU
0015A			U20
0016	00001.000	2210307-0004	IC, (USART) SERIAL I/O, SIO/9 CHAN A ONLY
0016A			U32
0017	00000.000	2210307-0001	IC, (USART) SERIAL I/O, SIO/0 BONDING
0017A			U32, ITEM 17 MAY BE
0017B			SUBSTITUTED AS AN ALTERNATE
0017C			FOR ITEM 16
0018	00000.000	2210307-0002	IC, (USART) SERIAL I/O, SIO/1 BONDING
0018A			U32, ITEM 18 MAY BE
0018B			SUBSTITUTED AS AN ALTERNATE
0018C			FOR ITEM 16

LIST OF MATERIALS

DATE 8/24/79
P/N 999947

Terminal Electronics PWB

0401
REV P

PRINT NUMBER	QUANTITY PER ASSEMBLY	PART NUMBER	DESCRIPTION
0019	00000.000	2210307-0003	IC,(USART) SERIAL I/O,SIO/2 BONDING
0019A			U32,ITEM 19 MAY BE
0019B			SUBSTITUTED AS AN ALTERNATE
0019C			FOR ITEM 16
0020	00002.000	2210302-0001	IC, COUNTER TIMER CKT,28 PIN CERAMIC PKG 056708-780A-CTC
0020A			U21,U22
0021	00001.000	0996750-0001	IC,TMS-4732NLZA3226,4096 X 8-BIT PREPGM
0021A			U11
0022	00001.000	2207625-0003	IC,8K X 8 ROM 820 TERMINAL
0022A			U9
0023	00001.000	2207625-0004	IC,8K X 8 ROM 820 TERMINAL
0023A			U10
0024	00002.000	0996203-0002	IC,S 5101L-1 1024BIT(256 X 4)ST CMOS RAM 034649-55101L-1
0024A			U4,U5
0025	00002.000	2210363-0001	IC, 1K X 8-BIT RAM, 24-PIN,DUAL-IN-LINE
0025A			U2,U3
0026	00001.000	0972900-7402	NETWORK SN74LS02N
0026A			U110
0027	00001.000	0972900-7404	NETWORK SN74LS04N
0027A			U19
0028	00001.000	0222222-7406	NETWORK SN7406N
0028A			U28
0029	00001.000	0972749-0001	NETWORK, SN74LS08N
0029A			U16
0030	00001.000	0972784-0002	NETWORK SN74LS14N
0030A			U1
0031	00004.000	0222222-7417	NETWORK-SN7417N
0031A			U104,U105,U108,U112
0032	00001.000	0972900-7109	NETWORK SN74LS109N
0032A			U40
0033	00001.000	0996399-0001	IC,SN74LS107N DUAL-NEGATIVE-EDGE
0033A			U30
0034	00002.000	0972900-7138	NETWORK SN74LS138N
0034A			U25,U26
0035	00001.000	0972686-0001	NETWORK-QUAD MULTIPLEXER, SN74LS157N
0035A			U35
0036	00004.000	0996089-0004	IC,SN74LS244N LINE DRIVER
0036A			U17,U29,U33,U34

LIST OF MATERIALS

Terminal Electronics PWB

DATE 8/24/79
P/N 999947

0401
REV P

PRINT NUMBER	QUANTITY PER ASSEMBLY	PART NUMBER	DESCRIPTION
0037	00001.000	0996755-0001	IC, SN74LS245N BUS XCVR TRANSITION
0037A			U31
0038	00002.000	0972120-0001	NETWORK, SN74259 8-BIT ADDRESSABLE LATCH
0038A			U18, U6
0039	00005.000	0996029-0001	IC, SN74LS273N OCTAL D-TYPE FLTP/FLOP
0039A			U7, U15, U27, U36, U37
0040	00002.000	0996015-0001	IC, QUAD LINE DRIVERS SN75188N
0040A			U41, U42
0041	00002.000	0972450-0002	NETWORK, SN75189AN/MC1489AL QUAD LINE RC
0041A			U43, U44
0042	00001.000	2206549-0001	PROM, PROGRAMMED, TACH PHASE DECODE
0042A			U8
0043	00001.000	2206550-0001	PROM, PROGRAMMED, MEMORY SELECT DECODE
0043A			U13
0044	00005.000	0972932-0001	SEMICONDUCTOR DEVICE, DIODE, IN914B
0044A			CR2, CR112, CR113, CR210, CR256
0045	00031.000	0539468-0002	DIODE, IN4002 1AMP 100PIV RECTIFIER
0045A			CR3, CR101-CR111, CR123-
0045B			CR132, CR135-CR138, CR204,
0045C			CR250-CR252, CR254
0046	00001.000	0539468-0007	DIODE, IN4007 1AMP 1000PIV RECTIFIER
0046A			CR258
0047	00001.000	0972116-0001	X DIODE UTG1249 (MAY USE IN5808/IN5809)
0047A			CR205
0048	00006.000	0996036-0003	DIODE, 3 AMP 100V RECTIFIER
0048A			CR114, CR116, CR118-CR121
0049	00001.000	0972164-0001	DIODE, MR501
0049A			CR255
0050	00005.000	0972164-0006	DIODE, 3 AMP 1,000V SILICONE
0050A			CR262-CR266
0051	00001.000	0803297-0001	DIODE, SCHOTTKY BARRIER, UHF MIXER
0051A			CR1
0052	00003.000	0972268-0006	DIODE IN4937 1 AMP
0052A			CR257, CR259, CR260
0053	00002.000	0972268-0002	DIODE IN4934-1 AMP
0053A			CR209, CR211
0054	00001.000	0996036-0004	DIODE, MR852 RECTIFIER SILICON FAST RCVY
0054A			CR203

LIST OF MATERIALS

DATE 8/24/79
P/N 999947

Terminal Electronics PWB

000 0401
REV P

PRINT NUMBER	QUANTITY PER ASSEMBLY	PART NUMBER	DESCRIPTION
0055	00002.000	0972460-0007	DIODE,SILICON,ZENER 1%
0055A			CR201,CR202
0056	00002.000	0972460-0006	DIODE E7918,SILICON,ZENER-1%
0056A			CR115,CR122
0057	00001.000	0801295-0062	SEMICONDUCTOR DEVICE,DIODE 1N5338B 5W
0057A			CR253
0058	00001.000	0972118-0001	DIODE, 1N5339B
0058A			CR207
0059	00001.000	0972118-0005	SEMICONDUCTOR DEVICE,DIODE-1N5350B
0059A			CR206
0060	00004.000	0801295-0084	SEMICONDUCTOR DEVICE,DIODE 1N5360B 5W
0060A			CR117,CR133,CR134,CR139
0061	00001.000	0996036-0006	DIODE,MR856 RECTIFIER SILICON FAST RCVY
0061A			CR261
0062	00008.000	0972057-0001	TRANSISTOR-A5T2222 NPN SILICON
0062A			Q2,Q3,Q6,Q103,Q104,Q107
0062B			Q202,Q252
0063	00003.000	0800523-0001	TRANSISTOR A5T2907 PNP SILICON
0063A			Q1,Q203,Q253
0064	00001.000	0772116-0003	TRANSISTOR,SYMM N-CHANNEL FET T1S73
0064A			Q201
0065	00001.000	0972542-0001	TRANSISTOR,HV PNP FN5416/S41802
0065A			Q251
0066	00004.000	0996712-0001	TRANSISTOR,TIP105 P-N-P POWER
0066A			Q101,Q108,Q109,Q113
0067	00006.000	0996801-0001	TRANSISTOR,TIP100 N-P-N,DARLINGTON
0067A			Q110,Q111,Q114-Q117
0068	00005.000	0996711-0002	TRANSISTOR,TIP73A N-P-N POWER
0068A			Q102,Q105,Q106,Q119,Q254
0069	00001.000	0972955-0001	XSTR 2N2369A,NPN,HIGH SPEED SW,TO-18
0069A			Q5
0070	00001.000	0996703-0001	TRANSISTOR,2N6545 NPN, 125 WATT POWER
0070A			Q250
0071	00001.000	0800257-0001	TRANSISTOR
0071A			Q4
0072	00001.000	0972465-0003	THYRISTORS,TRIODE-P-N-P-N SIL
0072A			Q255
0073	00001.000	0999892-0001	TRANSFORMER,SWITCHMODE,SCREENED,230VAC

LIST OF MATERIALS

DATE 8/24/79
P/N 999947

Terminal Electronics PWB

0401
REV P

PRINT NUMBER	QUANTITY PER ASSEMBLY	PART NUMBER	DESCRIPTION
0073A			T201
0074	00001.000	0996873-0001	TOROID CORE
0074A			T250
0075	00002.000	0972946-0025	RES FIX 22.0 OHM 5 % .25 W.CARBON FILM
0075A			R21,R22
0076	00001.000	0972946-0031	RES FIX 39.0 OHM 5 % .25 W.CARBON FILM
0076A			R27
0077	00001.000	0972946-0129	RES FIX 470K OHM 5 % .25 W CARBON FILM
0077A			R217
0078	00004.000	0972946-0037	RES FIX 68.0 OHM 5 % .25 W.CARBON FILM
0078A			R30-R33
0079	00001.000	0972946-0038	RES FIX 75.0 OHM 5 % .25 W.CARBON FILM
0079A			R9
0080	00004.000	0972946-0041	RES FIX 100 OHM 5 % .25 W CARBON FILM
0080A			R13,R104,R138,R255
0081	00001.000	0972946-0043	RES FIX 120 OHM 5 % .25 W CARBON FILM
0081A			R19
0082	00001.000	0972946-0045	RES FIX 150 OHM 5 % .25 W CARBON FILM
0082A			R268
0083	00001.000	0972946-0047	RES FIX 180 OHM 5 % .25 W CARBON FILM
0083A			R8
0084	00001.000	0972946-0050	RES FIX 240 OHM 5 % .25 W CARBON FILM
0084A			R16
0085	00001.000	0972946-0051	RES FIX 270 OHM 5 % .25 W CARBON FILM
0085A			R208
0086	00003.000	0972946-0053	RES FIX 330 OHM 5 % .25 W CARBON FILM
0086A			R23 R120 R121
0087	00006.000	0972946-0057	RES FIX 470 OHM 5 % .25 W CARBON FILM
0087A			R14,R15,R17,R18,R250,R261
0088	00001.000	0972946-0058	RES FIX 510 OHM 5 % .25 W CARBON FILM
0088A			R26
0089	00001.000	0972946-0059	RES FIX 560 OHM 5 % .25 W CARBON FILM
0089A			R269
0090	00005.000	0972946-0065	RES FIX 1.0K OHM 5% .25 W CARBON FILM
0090A			R10,R12,R28,R110,R126
0091	00011.000	0972946-0072	RES FIX 2.0K OHM 5 % .25 W CARBON FILM
0091A			R1-R7,R11,R112,R127,R228
0092	00003.000	0972946-0077	RES FIX 3.3K OHM 5 % .25 W CARBON FILM

LIST OF MATERIALS

DATE 8/24/79
P/N 999947

Terminal Electronics PWB

0401
REV P

PRINT NUMBER	QUANTITY PER ASSEMBLY	PART NUMBER	DESCRIPTION
0092A			R134,R206,R210
0093	00002.000	0972946-0081	RES FIX 4.7K OHM 5 % .25 W CARBON FILM
0093A			R200,R254
0094	00007.000	0972946-0085	RES FIX 6.8K OHM 5 % .25 W CARBON FILM
0094A			R20 R24 R29 R34 R35 R37
0094B			R209
0095	00002.000	0972946-0089	RES FIX 10K OHM 5% .25 W CARBON FILM
0095A			R213,R264
0096	00001.000	0972946-0093	RES FIX 15K OHM 5% .25 W CARBON FILM
0096A			R216
0097	00001.000	0972946-0109	RES FIX 68 K OHM 5 % .25 W CARBON FILM
0097A			R203
0098	00001.000	0972946-0117	RES FIX 150K OHM 5 % .25 W CARBON FILM
0098A			R25
0099	00002.000	0972946-0137	RES FIX 1.0M OHM 5 % .25 W CARBON FILM
0099A			R109,R128
0100	00001.000	0972946-0139	RES FIX 1.2M OHM 5 % .25 W CARBON FILM
0100A			R220
0101	00001.000	0972946-0145	RES FIX 2.2M OHM 5 % .25 W CARBON FILM
0101A			R218
0102	00001.000	0972947-0149	RES,FXD,FILM,INSUL, 1/2W, 3.3 MEG OHMS
0102A			R140
0103	00003.000	0972947-0031	RES FIX 39 OHM 5 % .5 W CARBON FILM
0103A			R111,R118,R119
0104	00005.000	0972947-0053	RES FIX 330 OHM 5% .5 W CARBON FILM
0104A			R101,R113,R116,R132,R135
0105	00002.000	0972947-0102	RES FIX 36 K OHM 5% .5 W CARBON FILM
0105A			R262,R266
0106	00001.000	0972947-0089	RES FIX 10 K OHM 5% .5 W CARBON FILM
0106A			R253
0107	00001.000	0972947-0137	RES FIX 1.0M OHM 5% .5 W CARBON FILM
0107A			R229
0108	00001.000	0972554-0001	RESISTOR,FIXED,WIREWOUND.1 OHM 5W 5%
0108A			R102
0109	00001.000	0972947-0109	RES FIX 68 K OHM 5% .5 W CARBON FILM
0109A			R263
0111	00002.000	0972554-0011	RESISTOR,.25 OHM 3W 1% FX WW
0111A			R125,R133

LIST OF MATERIALS

DATE 8/24/79
P/N 999947

Terminal Electronics PWB

0401
REV P

PRINT NUMBER	QUANTITY PER ASSEMBLY	PART NUMBER	DESCRIPTION
0112	00001.000	0972947-0055	RES FIX 390 OHM 5% .5 W CARBON FILM
0112A			R207
0113	00001.000	0972978-0149	RESISTOR,.10 MEG OHM 1W 5% FIXED CMPSN
0113A			R257
0114	00001.000	0972947-0072	RES FIX 2.0K OHM 5% .5 W CARBON FILM
0114A			R252
0115	00001.000	0972947-0038	RES FIX 75 OHM 5% .5 W CARBON FILM
0115A			R231
0116	00002.000	0972947-0065	RES FIX 1.0K OHM 5% .5 W CARBON FILM
0116A			R232,R233
0117	00001.000	0972947-0079	RES FIX 3.9K OHM 5% .5 W CARBON FILM
0117A			R226
0118	00001.000	0972055-0003	RESISTOR,600 OHM 25W NON-INDUCTIVE WW
0118A			R267
0119	00001.000	0972942-0191	RESISTOR,12.7K OHMS 5W 5% WW PWR
0119A			R270
0120	00001.000	0972942-0190	RESISTOR,.5 OHM 5W 5% FX,WW PWR
0120A			R251
0121	00002.000	0539370-0440	RES FIX FILM 3.74K OHM 1% .25 WATT
0121A			R36,R259
0122	00001.000	0539370-0405	RES FIX FILM 1.62K OHM 1% .25 WATT
0122A			R221
0123	00001.000	0539370-0410	RES FIX FILM 1.82K OHM 1% .25 WATT
0123A			R222
0124	00001.000	0539370-0477	RES FIX FILM 9.09K OHM 1% .25 WATT
0124A			R205
0125	00001.000	0539370-0479	RES FIX FILM 9.53K OHM 1% .25 WATT
0125A			R204
0126	00001.000	0539370-0460	RES FIX FILM 6.04K OHM 1% .25 WATT
0126A			R137
0127	00001.000	0539370-0504	RES FIX FILM 17.4K OHM 1% .25 WATT
0127A			R139
0128	00006.000	0539370-0481	RES FIX FILM 10.0K OHM 1% .25 WATT
0128A			R107,R114,R141-R143,R230
0129	00001.000	0539370-0558	RES FIX FILM 63.4K OHM 1% .25 WATT
0129A			R122
0130	00001.000	0539370-0512	RES FIX FILM 21.0K OHM 1% .25 WATT
0130A			R106

LIST OF MATERIALS

DATE 8/24/79
P/N 999947

Terminal Electronics PWB

000 0401
REV P

PRINT NUMBER	QUANTITY PER ASSEMBLY	PART NUMBER	DESCRIPTION
0131	00002.000	0539370-0514	RES FIX FILM 22.1K OHM 1% .25 WATT
0131A			R105,R108
0132	00001.000	0539370-0577	RES FIX FILM 100 K OHM 1% .25 WATT
0132A			R202
0133	00003.000	0539370-0510	RES FIX FILM 20.0K OHM 1% .25 WATT
0133A			R115,R117,R260
0134	00001.000	0539370-0502	RES FIX FILM 16.5K OHM 1% .25 WATT
0134A			R256
0135	00001.000	0539370-0539	RES FIX FILM 40.2K OHM 1% .25 WATT
0135A			R123
0136	00001.000	0539370-0450	RES FIX FILM 4.75K OHM 1% .25 WATT
0136A			R225
0137	00001.000	0539370-0467	RES FIX FILM 7.15K OHM 1% .25 WATT
0137A			R219
0138	00001.000	0539370-0469	RES FIX FILM 7.50K OHM 1% .25 WATT
0138A			R103
0139	00001.000	0532439-0399	RESISTOR,1.40K OHMS 1% 1W WW FIXED
0139A			R215
0140	00001.000	0539812-0064	RESISTOR,8.25K OHM 1/8W .1% FX FILM
0140A			R130
0141	00001.000	0539812-0001	RES FIX FILM 4.12K OHM .1% .125 WATT
0141A			R224
0142	00004.000	0539812-0057	RES FIXED 10K OHMS .1%
0142A			R129,R131,R214,R223
0143	00001.000	0539812-0066	RES, 11.3K OHMS 1/8W,.1% FXD FILM
0143A			R124
0145	00001.000	0538425-0119	RESISTOR,22K OHMS 2W 5% FIXED CMPSN
0145A			R258
0146	00001.000	0538425-0123	RES 33000. OHM 5% 2WATT FIX COMP
0146A			R265
0147	00022.000	0972763-0021	CAP.,FIXED,AXIAL LEAD,.047 UF,+80%,-20%
0147A			C1-C6,C11-C14,C16-21,C23,
0147B			C102,C103,C106,C107,C215
0149	00001.000	0972929-0361	CAP FIX CERAMIC 10.0 PF 10 % 200 V
0149A			C8
0150	00002.000	0972929-0367	CAP FIX CERAMIC 22.0 PF 10 % 200 V
0150A			C9,C10
0151	00001.000	0972929-0376	CAP FIX CERAMIC 68.0 PF 10 % 200 V

LIST OF MATERIALS

DATE 8/24/79
P/N 999947

Terminal Electronics PWB

000 0401
REV P

PRINT NUMBER	QUANTITY PER ASSEMBLY	PART NUMBER	DESCRIPTION
0151A			C22
0152	00001.000	0972929-0391	CAP FIX CERAMIC 470 PF 10 % 200 V
0152A			C7
0153	00003.000	0972929-0403	CAP .0022 UF 10% 100V
0153A			C15,C108,C200
0154	00001.000	0410529-0203	CAP FIX CERAMIC .02UF +80%-20% 600 V
0154A			C264
0155	00001.000	0972924-0007	CAP FIX TANT SOLID 120 MFD 10 % 10
0155A			C261
0156	00001.000	0972924-0013	CAP FIX TANT SOLID 2.2 MFD 10 % 20
0156A			C263
0157	00003.000	0972924-0014	CAP FIX TANT SOLID 15 MFD 10 % 20
0157A			C206,C207,C251
0158	00001.000	0972924-0017	CAP FIX TANT SOLID 1.0 MFD 10 % 35
0158A			C202
0159	00001.000	0058023-0016	CAP FIX .100 MFD 5 % 100V MYLAR FOIL
0159A			C104
0160	00001.000	0972928-0011	CAP FIX MICA 500V 3000 PF 5 %
0160A			C256
0161	00001.000	0972757-0003	CAP, FIXED CERAMIC 150 PF 10% 50V
0161A			C105
0162	00004.000	0412645-0015	CAPACITOR,.1 UF +80,-20% 500VDC CER DIEI
0162A			C208-C210,C257
0163	00002.000	0972929-0415	CAP FIX CERAMIC .010 UF 10 % 100 V
0163A			C201,C253
0164	00002.000	0972927-0020	CAP FIX MICA 500V 51.0 PF 5 %
0164A			C252,C255
0165	00002.000	0972929-0433	CAP FIX CERAMIC .100 UF 10 % 50 V
0165A			C250,C260
0166	00001.000	0996810-0007	CAPACITOR,3900PF 400V 20% CER,DIN TYPE
0166A			C262
0167	00001.000	0410529-0103	CAP FIX CERAMIC .010 MF GMV 1 KV
0167A			C254
0168	00001.000	0972965-0024	CAP FIX CERAMIC .100 MF 10% 100V
0168A			C101
0169	00002.000	0972601-0004	CAPACITOR,330UF 200V 10% ALUM ELECTLT
0169A			C258,C259
0170	00001.000	0972931-0024	CAP, FIXED 14000MFD 7.5V 10%

LIST OF MATERIALS

DATE 8/24/79
P/N 999947

Terminal Electronics PWB

000 0401
REV P

PRINT NUMBER	QUANTITY PER ASSEMBLY	PART NUMBER	DESCRIPTION
0170A			C205
0171	00002.000	0972931-0049	CAP,FXD,ELCTLT,AL,1800 MFD,20V,10%+-75
0171A			C211,C212
0172	00002.000	0972931-0084	CAPACITOR,2300UF 40V FX ELCTLT ALUM
0172A			C203,C204
0173	00001.000	2210188-0002	SOCKET,LOW PROFILE,DIP, 14 PINS
0173A			TP7
0174	00003.000	2210188-0005	SOCKET, LOW PROFILE, DIP, 20 PINS
0174A			XU23,XU24,XU45
0175	00006.000	2210188-0007	SOCKET, LOW PROFILE, DIP, 24 PINS
0175A			XU2,XU3,XU9-XU12
0176	00002.000	2210188-0008	SOCKET,LOW PROFILE,DIP,28 CONT
0176A			XU21,XU22
0177	00002.000	2210188-0009	SOCKET, LOW PROFILE, DIP, 40 PINS
0177A			XU20,XU32
0178	00001.000	0983910-0001	SUPPORT,TONE GENERATOR
0179	00001.000	0537399-0012	FUSE 5AMP .014 OHM
0179A			F200
0180	00003.000	0537399-0010	FUSE 3AMP
0180A			F101,F102,F103
0181	00001.000	0416434-0303	FUSE 3.0 A 250V 3AG
0181A			F250
0182	00002.000	0772635-0001	CLIP,FUSE
0183	00003.000	0972808-0001	THERMISTOR, DISC, 5 OHM
0183A			R271 R274 R275
0184	00001.000	0996865-0005	HEADER ASSY,9 POS RIGHT ANGLE,.100
0184A			J103
0185	00002.000	0972519-0023	SOCKET,SINGLE-IN-LINE 12 POS(GOLD CONT)
0185A			J10
0186	00001.000	0983836-0003	CABLE,HEATSINK GROUND,BLK/WHT,4.20"
0187	00002.000	0983836-0002	CABLE,HEATSINK GROUND,GRN/YEL,4.20"
0189	00145.000	0972456-0002	PIN,.025 SQUARE
0189A			E3 THRU E7,E15,E16
0189B			E205 THRU E216,E219,E220,
0189C			E234,E235,E262 THRU E265,
0189D			J3-1 THRU J3-6,
0189E			J3-8 THRU J3-24,
0189F			J6-1 THRU J6-4,J6-6,

LIST OF MATERIALS

DATE 8/24/79
P/N 999947

Terminal Electronics PWB

000 0401
REV P

PRINT NUMBER	QUANTITY PER ASSEMBLY	PART NUMBER	DESCRIPTION
0189G			J8-1, J8-3 THRU J8-8,
0189H			J9-1, J9-2, J9-4,
0189I			J11-1 THRU J11-7,
0189J			J11-9 THRU J11-15, J11-18,
0189K			J12-1 THRU J12-3,
0189L			J12-5 THRU J12-28,
0189M			J13-1 THRU J13-7,
0189N			J13-9 THRU J13-15, J13-18,
0189P			J101-2 THRU J101-10,
0189Q			J104-1 THRU J104-4,
0189R			J105-1, J105-2, J105-4,
0189S			J106-1, J106-3 THRU J106-5,
0189T			J203-1, J203-2, J203-4
0190	00000.000	0972494-0001	PIN, .025 SQUARE
0191	00003.000	0996706-0002	POST, .715LG PRINTED CIRCUIT
0191A			E221 E271 E281
0192	00013.000	0972487-0001	JUMPER PLUG, CONNECTOR BLACK
0193	00018.000	0996521-0018	INSULATOR, THERMALLY CONDUCTIVE, .800 W
0194	00001.000	0800482-0003	HEATSINK, TO-3 ALUM
0195	00001.000	0999802-0001	HEATSINK, POWER SUPPLY
0196	00001.000	0999803-0001	HEATSINK, CARRIAGE DRIVER
0197	00001.000	0999804-0001	HEATSINK, PAPER DRIVER
0198	00001.000	0999863-0001	HEATSINK, PRINTHEAD/RIBBON DRIVE MOTOR
0199	00001.000	0232583-0008	TO-5 MOUNTING PAD, 4-LEADS, NYLON
0200	AR	0417559-0001	SILICONE RUBBER (RTV) DOW 3140
0201	AR	0417200-0004	PRIMER, SILICONE RUBBER-RED
0202	AR	0415886-0001	GREASE, SILICONE, HEAT COND. (8 OZ TUBE)
0204	00001.000	0972306-0003	COVER, RND-1.807LG .019THK ALUM, SEAMLESS
0205	00001.000	0972621-0001	SPRING, RING
0206	00004.000	0972355-0006	STUD, SELF-CLINCHING 4-40 X .750LG PWB
0207	00001.000	0418801-0004	CRYSTAL, QUARTZ 4.000 MHZ HC-18/U
0207A			Y1
0208	00002.000	2210323-0001	BUS BAR, PCB, 311.40MM (12.26 IN.)
0209	00001.000	0972461-0001	DISC, SOUND-PIEZO-ELECT 3200 +/- 600 HZ
0209A			DS1
0210	00003.000	0972988-0013	SCREW 4-40 X .250 PAN HEAD CRES
0211	00015.000	0972988-0016	SCREW 4-40 X .438 PAN HEAD CRES
0212	00001.000	0972988-0023	SCREW 4-40 X 1.50 PAN HEAD CRES

LIST OF MATERIALS

DATE 8/24/79
P/N 999947

Terminal Electronics PWB

0401
REV P

PRINT NUMBER	QUANTITY PER ASSEMBLY	PART NUMBER	DESCRIPTION
0213	00001.000	0972988-0014	SCREW 4-40 X .312 PAN HEAD CRES
0214	00024.000	0416453-0021	NUT, PLAIN, 4-40 UNC-2B HEX, CRES, SMALL
0215	00032.000	0411027-0803	WASHER .125 X .250 X .022 FLAT CRES
0216	00002.000	0416622-0011	WASHER #4 FLAT
0217	00019.000	0411104-0135	WASHER, LOCK-SPRING, HELICAL, #4
0218	00005.000	0411101-0057	LOCKWASHER # 4 EXTERNAL TOOTH CRES
0219	00019.000	0972628-0001	WASHER, #4 .115ID .2000D-SHLDR NON-MET
0220	00002.000	0416925-0600	SPACERS-SCREW & BOLT #6 1/4 X.049
0221	00001.000	0416925-0417	SPACERS-SCREW AND BOLT #4 3/16 X .028
0222	00002.000	0999862-0001	SPACER, POWER TRANSISTOR
0223	00000.200	0411400-0018	WIRE, BARE TINNED, 18AWG, COPPER BUS
0224	00000.500	0411400-0022	WIRE 22AWG ELETRO-TIN-PLATED, COPPER
0225	AR	2210083-0003	WIRE, ELEC, COND U/L STYLE 1213, 24 AWG
0226	00002.000	0418212-0040	STRAP, TIEDOWN, ADJUSTABLE, PLASTIC
0227	00000.050	0411634-1310	SLEEVE, PVC, .133 DIA. CLEAR
0231	00001.000	0999880-0001	BATTERY PACK
0232	00001.000	0996707-0002	THERMISTOR, DISC, 100 OHMS
0232A			R227
0233	00000.000	0996914-0001	CLIP, CARTRIDGE FUSE .25 DIA.
0233A			ITEM 233 MAY BE SUBSTITUTED
0233B			AS AN ALTERNATE FOR ITEM
0233C			182
0234	00000.000	2210422-0001	IC, TRANSCIVER, BUS, OCTAL
0234A			ITEM 234 MAY BE SUBSTITUTED
0234B			FOR ITEM 37. IF ITEM 234 IS
0234C			USED, IT IS TO BE INSTALLED
0234D			IN LOCATION U31A
0235	REF	0994396-9901	PROCEDURE, SITE & DATE CODE SERIALIZATION
0236	00001.000	0185113-0001	X SPACER XST TO-18 CASE

LIST OF MATERIALS

DATE 07-19-78
P/N 0999913

Carriage Assembly, Printhead

000 1
REV *

PRINT ITEM NUMBER	QUANTITY PER ASSEMBLY	PART NUMBER	DESCRIPTION
0001	00001.000	0994487-0001	CARRIAGE, PRINTHEAD
0002	00002.000	0972405-0200	BEARING,.500LG .7530D BRZ OIL IMPREGNATED
0003	00002.000	0994484-0001	WIPER, GUIDE ROD
0004	00002.000	0994488-0001	RETAINER, WIPER
0005	00001.000	0994489-0001	PLATE, NUT
0006	00001.000	0972988-0035	SCREW 6-32 X 1.25 PAN HEAD CRES
0007	00001.000	0999912-0001	BEARING,LOWER-CARRIAGE

NOTES UNLESS OTHERWISE SPECIFIED
 1 MOUNTING HARDWARE PROVIDED WITH ITEM 1 WHEN USED AS ALTERNATE 1. MTR
 2 ALIGN FLATS ON MTR SHAFT AND CAPSTAN
 3 MARK ASSY NUMBER AND REV ON ITEM 6 PER PROC 1.10.1. MARK SITE/DATE CODE ON ITEM 6 PER PROC 1.10.1 OF 2 AND PER ITEMS, PARAGRAPH 4.0 WHERE SHOWN.

4 REMOVE HOLE PLUG/COVER SO MOTOR SHAFT CAN BE SUPPORTED WHILE INSTALLING CAPSTAN. REPLACE AFTER CAPSTAN INSTALLATION.

5 INSTALL ON CAPSTAN PRIOR TO INSTALLING CAPSTAN ON MOTOR

REV	DESCRIPTION	DATE	APPROVED
C	416975 (C) <i>Jim K...</i> 10-15-76		
	LM-0001 DELETED ITEMS 1,2,5,6,7,9,11 THRU 17,19 ADDED ITEM 1 (P/N 994336-1, QTY 1) LM-0002 DELETED ITEMS 1,2,5, THRU 19 ADDED ITEM 1 (P/N 994336-1, QTY 1)		
FORMAL RELEASE			
D	CN414897 <i>James King</i> 1/17/77 <i>James</i> NOTE 3 WAS MARK PER ITEM 5 AND PROCESS 1 WHERE SHOWN		
E	CN421017 C EDWARDS 3-22-77 <i>Edwards</i> 1) ADDED REFERENCES TO ITEM 6 IN NOTE 3 2) ADDED ITEM 6 TO LM		
F	CN424044 <i>James King</i> 2-18-77 <i>James</i> 1) ITEMS 1 & 3 QTY WAS 1 (2) ADDED ITEMS A, B, C & 3A, B, C (3) ADDED ITEM 7 (4) AND 7 (1) 1-- WHEN USED -- ITEM 7 (5) F/D REPLACED ITEM 1 & 3 WITH ITEM 7		
G	CN437192 (C) <i>Edwards</i> (1) ADDED -3 & -4 4/1/77 <i>Edwards</i> TO LM AND F/D		
H	CN437156 (D) J BAIZA (1) 8/14/78 <i>Edwards</i> ADDED BOSS CAP TO CAPSTAN (2) ADDED NOTE (3) CHANGE 240 ± 0.15 TO 240 ± 0.15 (4) ADDED ITEM 8 TO ALL L/M'S -0001 THRU -0004		
J	CN445476 (B) <i>Edwards</i> (1) ADDED ITEM 9 TO -3 AND -4 (2) ADDED ITEM 9 TO F/D & BEL DIMS 11/13/78 <i>Edwards</i>		
K	CN439544 (C) <i>Edwards</i> (1) ADDED VIEW A (2) KEY NOTE 3 (3) ADDED PROC 2 AND DELETED CR. WHT FROM PROC 1 11/20/77 <i>Edwards</i>		

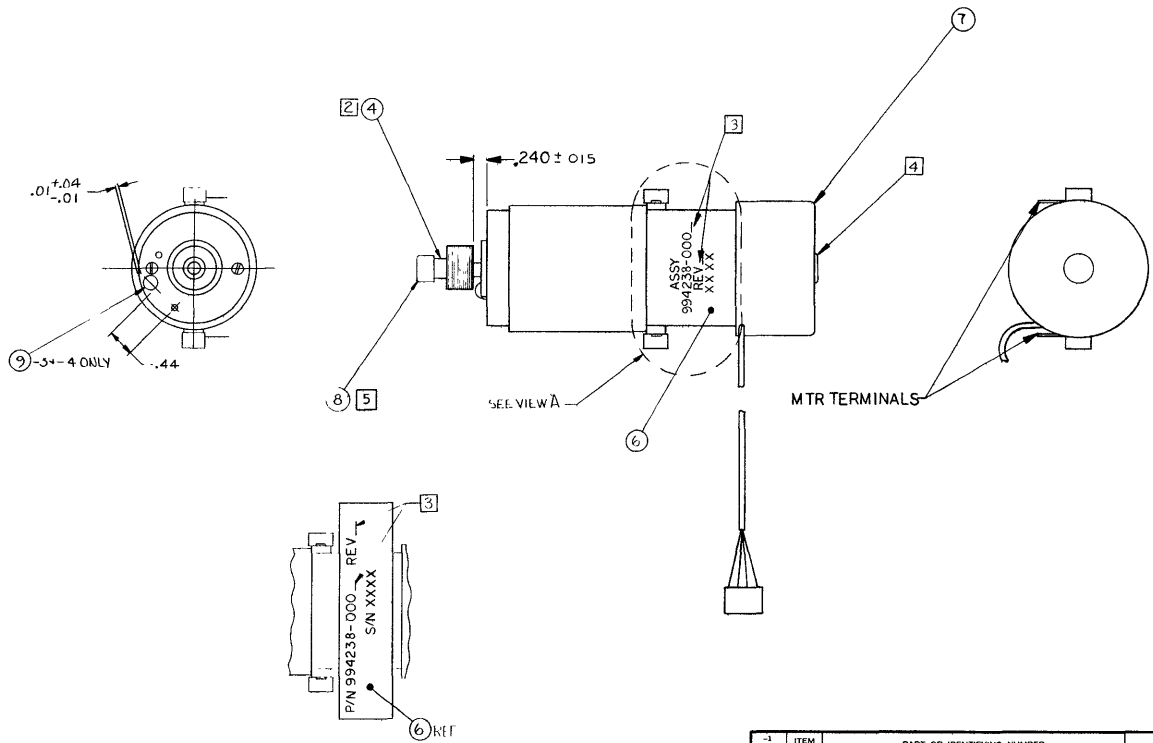

PART NUMBER	DESCRIPTION
994238-0004	CARRIAGE DRIVE MOTOR ASSY 10 ± 16.5 CPI (82.0)
994238-0003	CARRIAGE DRIVE MOTOR ASSY 10 CPI (82.0)
994238-0002	CARRIAGE DRIVE MOTOR ASSEMBLY -10 ± 16.5 CPI
994238-0001	CARRIAGE DRIVE MOTOR ASSEMBLY -10 CPI

6-116

MARK	100-00	HEIGHT .10, COLOR BLK	3
MARK	100-02	21 HEIGHT .12, COLOR BLK	3
IDENT	F SPEC	NO	ADDITIONAL
PROCESS	CLASSIFICATION		
PROCESSES - FOR CORRELATION TO GOVT/IND SPECIFICATIONS SEE TI DRAWING 72947			

VIEW A
 ALTERNATE FORMAT FOR LABEL
 (LABEL SHOWN BEFORE INSTALLATION)

ITEM NO	QTY	PART OR IDENTIFYING NUMBER	NOMENCLATURE OR DESCRIPTION	PROCUREMENT SPECIFICATION	NOTES
PARTS LIST					
999687	8740		MOTOR ASSY, CARRIAGE DRIVE		
994183	8733				
UNLESS OTHERWISE SPECIFIED • DIMENSIONS ARE IN INCHES • TOLERANCES - ANGLES ±1° • 3 PLACE DECIMALS ± 0.10 • 2 PLACE DECIMALS ± 0.2 • INTERPRET DRAWING PER MIL Q100 • REMOVE ALL BURRS AND SHARP EDGES • CONCENTRICITY MACHINED DIAMETERS: 0.12 FIM • DIMENSIONAL LIMITS APPLY BEFORE PROCESSES • PARENTHEICAL INFO FOR REF ONLY HOLE TOLERANCE 0.13 THRU .004 1.16 THRU .005 .125 .001 1.50 .001 .501 .008 1.751 .010 1.750 .001 1.000 .001 2.000 .001					
APPLICATION			DATED: 10/15/76 BY: <i>Edwards</i> CHECKED: 10/26/76 BY: <i>Edwards</i> DATE: 11/4/76 DATE: 11/23/76	TEXAS INSTRUMENTS INCORPORATED DALLAS, TEXAS	DTP (P/N) NO. 994238 DRAWING NO. 994238 SCALE 1/1 SHEET

LIST OF MATERIALS

DATE 10-27-78
P/N 994238

Carriage Drive Assembly

000 1
REV K

PRINT ITEM NUMBER	QUANTITY PER ASSEMBLY	PART NUMBER	DESCRIPTION
0001	00000.000	0996336-0001	ENCODER, SHAFT
0001A			ITEM 1 CAN BE USED WITH
0001B			ITEM 3 AS AN ALTERNATE TO
0001C			ITEM 7
0003	00000.000	0994206-0001	MOTOR-D.C. SERVO 25 AMPERES
0003A			ITEM 3 CAN BE USED WITH -
0003B			ITEM 1 AS AN ALTERNATE TO
0003C			ITEM 7
0004	00001.000	0994177-0001	CAPSTAN, MOTOR
0005	REF	0994396-9901	PROCEDURE, SITE & DATE CODE SERIALIZATION
0006	AR	0232208-7000	LABEL 1X3INS RECTL SELF-ADHESIVE
0007	00001.000	0994437-0001	ENCODER/MOTOR ASSEMBLY
0008	00001.000	2210037-0001	FASTENER, PLASTIC BOSS

DATE 10-27-78
P/N 994238

000 2
REV K

0001	00000.000	0996336-0002	ENCODER, SHAFT
0001A			ITEM 1 CAN BE USED WITH
0001B			ITEM 3 AS AN ALTERNATE TO
0001C			ITEM 7
0003	00000.000	0994206-0001	MOTOR-D.C. SERVO 25 AMPERES
0003A			ITEM 3 CAN BE USED WITH -
0003B			ITEM 1 AS AN ALTERNATE TO
0003C			ITEM 7
0004	00001.000	0994177-0001	CAPSTAN, MOTOR
0005	REF	0994396-9901	PROCEDURE, SITE & DATE CODE SERIALIZATION
0006	AR	0232208-7000	LABEL 1X3INS RECTL SELF-ADHESIVE
0007	00001.000	0994437-0002	ENCODER/MOTOR ASSEMBLY
0008	00001.000	2210037-0001	FASTENER, PLASTIC BOSS

LIST OF MATERIALS

DATE 10-27-78
P/N 994238

Carriage Drive Assembly

000 3
REV K

PRINT ITEM NUMBER	QUANTITY PER ASSEMBLY	PART NUMBER	DESCRIPTION
0001	00000.000	0996336-0003	ENCODER, SHAFT TWO QDRK AT 288 PUL P/REV
0001A			ITEM 1 CAN BE USED WITH
0001B			ITEM 3 AS AN ALTERNATE TO
0001C			ITEM 7
0003	00000.000	0994206-0001	MOTOR-D.C. SERVO 25 AMPERES
0003A			ITEM 3 CAN BE USED WITH
0003B			ITEM 1 AS AN ALTERNATE TO
0003C			ITEM 7
0004	00001.000	0994177-0001	CAPSTAN, MOTOR
0005	REF	0994396-9901	PROCEDURE, SITE & DATE CODE SERIALIZATION
0006	AR	0232208-7000	LABEL 1X3INS RECTL SELF-ADHESIVE
0007	00001.000	0994437-0003	ENCODER/MOTOR ASSEMBLY-19.0"CA LG
0008	00001.000	2210037-0001	FASTENER, PLASTIC BOSS
0009	00001.000	2210005-0003	BUMPER, RUBBER, ADHESIVE, GRAY

DATE 10-27-78
P/N 994238

000 4
REV K

0001	00000.000	0996336-0004	ENCODER, SHAFT FOUR QDRTR, 2/288 2/475 PUL
0001A			ITEM 3 CAN BE USED WITH
0001B			ITEM 1 AS AN ALTERNATE TO
0001C			ITEM 7
0003	00000.000	0994206-0001	MOTOR-D.C. SERVO 25 AMPERES
0003A			ITEM 3 CAN BE USED WITH
0003B			ITEM 1 AS AN ALTERNATE TO
0003C			ITEM 7
0004	00001.000	0994177-0001	CAPSTAN, MOTOR
0005	REF	0994396-9901	PROCEDURE, SITE & DATE CODE SERIALIZATION
0006	AR	0232208-7000	LABEL 1X3INS RECTL SELF-ADHESIVE
0007	00001.000	0994437-0004	ENCODER/MOTOR ASSEMBLY-19.0"CA LG
0008	00001.000	2210037-0001	FASTENER, PLASTIC BOSS
0009	00001.000	2210005-0003	BUMPER, RUBBER, ADHESIVE, GRAY

4

3

2

1

NOTES, UNLESS OTHERWISE SPECIFIED

- 1 COLOR (BLACK, TYPE 6 OR WHITE, TYPE 9) SHALL CONTRAST COLOR OF ITEM 3.
- 2 SUPPORT SHAFT OF FAN (ITEM 1) AXIALLY WHILE INSTALLING FAN BLADE (ITEM 2)
- ~~3 ADD TUBING (ITEM 9) TO SHIELD CABLE TO BE FLUSH TO CONNECTOR (ITEM 3) AND ALLOW ONE TENTH INCH MAX GAP BETWEEN MOTOR SLEEVING~~
- 4 INSTALL KEY (ITEM 5) IN POSITION P203-3
- 5 PIN 1 IDENTIFIER IS VENDOR NAME MOLDED INTO HOUSING

WIRING LIST					
WIRE NO	DESCRIPTION	START STATION	FINISH STATION	REMARKS	ITEM NO
1	FAN MOTOR	B1-RED	P203-1	+12 VOLTS	1
2	FAN MOTOR	B1-BLACK	P203-2	GND	1
3	FAN MOTOR	B1-SHIELD	P203-4	3 SHIELD	1

REVISIONS			
REV	DESCRIPTION	DATE	APPROVED
A	CN430882 R Wilson 9/17/78	9/17/78	JW
LM UPDATES			
B	CN439701 J. CLARK 5/15/76	5/15/76	J. Spence
1.) IN NOTE 1 ITEM 3 WAS ITEM 4 IN NOTE 2 ITEM 9 WAS WAS ITEM 7			
C	CN439734 J. CLARK 5/30/76	5/30/76	J. Spence
1.) B-2 FAR SIDE WAS NEARSIDE			
D	CN445488 C. Holcomb 9-11-78	9-11-78	J. Spence
1.) Z C-2 DIM. WAS 24.00 ± .50 2.) DELETED FLAG NOTE 3 3.) LM QTY OF ITEM 9 WAS .04 FT. 4.) ADDED ITEM 10 5.) CHANGED PICTORIAL TO REFLECT ITEM CHANGES.			
E	CN445489 R. O. Spence 10/21/78	10/21/78	J. Spence
1.) Z C-3 DIM. .18 ± .03 WAS .12			
F	CN443018 P. AV. L. C. 1/14/79	1/14/79	J. Spence
ITEM 5 P/N 99642-1 WA -199 2599-1			

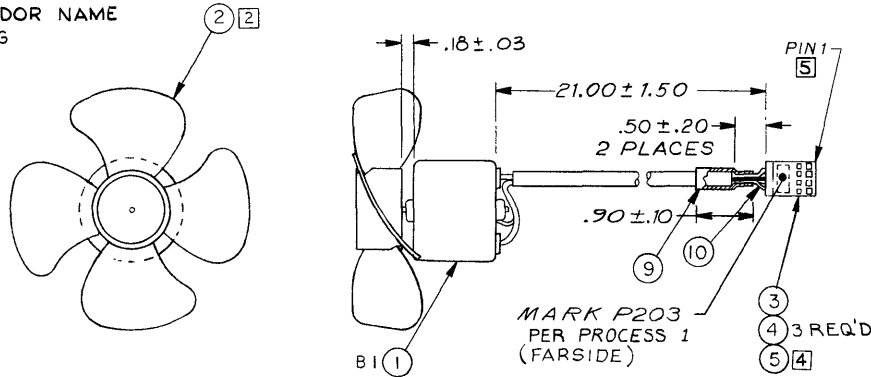

QTY	ITEM NO	PART OR IDENTIFYING NUMBER	NOMENCLATURE OR DESCRIPTION	PROCUREMENT SPECIFICATION	NOTES
			PARTS LIST		
			UNLESS OTHERWISE SPECIFIED • DIMENSIONS ARE IN INCHES • ANGLES ± 1° • TOLERANCES 3 PLACE DECIMALS = .010 • 2 PLACE DECIMALS = .02 • INTERPRET DRAWING PER MIL-D-1000 • REMOVE ALL BURRS AND SHARP EDGES • CONCENTRICITY MACHINED DIAMETERS .010 FIM • DIMENSIONAL LIMITS APPLY BEFORE PROCESSES • PARENTHETICAL INFO FOR REF ONLY		
			DWN BY: J. Spence 10-21-78 DATE: 10/21/78 CHKD BY: J. Spence 10/21/78 DATE: 10/21/78 APP'D BY: J. Spence 10/21/78 DATE: 10/21/78		
			TEXAS INSTRUMENTS INCORPORATED DALLAS, TEXAS		
			FAN ASSEMBLY		
			HOLE TOLERANCE: .251 ± .006 THRU .001 THRU .005 THRU .001 150 ± .001 250 ± .001 500 ± .001		
			999690 8740		
			NEXT ASSY USED ON APPLICATION		
			SIZE: FSCM NO: C 96214 DRAWING NO: 999819 SCALE: NONE SHEET		

1	MARK	100-07	710						
SEQ NO	IDENT	F SPEC	NO	ADDITIONAL	CLASSIFICATION	NOTES			

PROCESSES — FOR CORRELATION TO GOVT/AND SPECIFICATIONS, SEE TI DRAWING 729467

6-119

999819

4

3

2

1

30

LM

LIST OF MATERIALS

Fan Assembly

DATE 3-28-79
P/N 0999819

.000 1
REV F

PRINT ITEM NUMBER	QUANTITY PER ASSEMBLY	PART NUMBER	DESCRIPTION
0001	00001.000	0972486-0004	MOTOR,FAN .12VDC 170MA CABLE LG 21"
0001A			B1
0002	00001.000	0996515-0001	FAN BLADE,3-IN X.078 DIA HUB BORE
0003	00001.000	0972484-0004	CONNECTOR HOUSING 4 CONTACT
0003A			P203
0004	00003.000	0972104-0001	CONTACT ELEC-LOCKING,WIRE-TO.025 SQ POST AMP
0005	00001.000	0996497-0001	KEYING PLUG CONNECTOR
0009	00000.080	0972146-0004	TUBING,.020THK X 1/8 HT SHRINKABLE .125ID
0010	00000.040	0410499-0008	INSULATION SLEEVING,TEFLON #18 NATURAL

4

3

2

1

NOTES, UNLESS OTHERWISE SPECIFIED

REVISIONS			
REV	DESCRIPTION	DATE	APPROVED
A	CN 428952 LM UPDATES	10/28/77	<i>[Signature]</i>

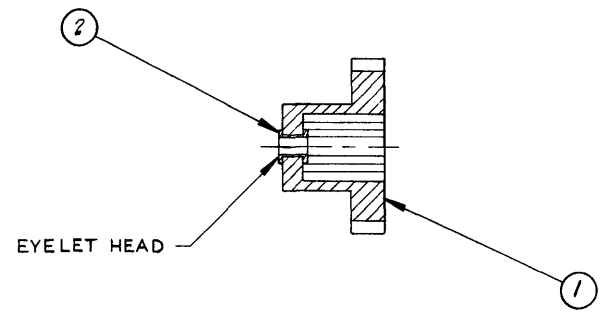
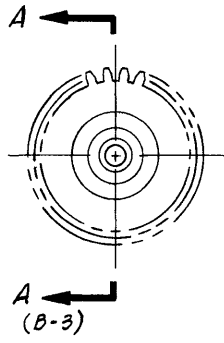

SECTION A-A
(B-4)

6-121

999780

SEQ NO	IDENT	F-SPEC	NO	ADDITIONAL	NOTES
	PROCESS			CLASSIFICATION	

PROCESSES — FOR CORRELATION TO GOVT/IND SPECIFICATIONS, SEE TI DRAWING 729467

QTY	ITEM NO	PART OR IDENTIFYING NUMBER	NOMENCLATURE OR DESCRIPTION	PROCUREMENT SPECIFICATION	NOTES
PARTS LIST					
			UNLESS OTHERWISE SPECIFIED • DIMENSIONS ARE IN INCHES • TOLERANCES ANGLES ±1° • 3 PLACE DECIMALS = 010 • 2 PLACE DECIMALS = 02 • INTERPRET DRAWING PER MIL D 1000 • REMOVE ALL BURRS AND SHARP EDGES • CONCENTRICITY MACHINED DIAMETERS .010 FIM • DIMENSIONAL LIMITS APPLY BEFORE PROCESSES • PARENTHETICAL INFO FOR REF ONLY	DATE 10-2-77 31 OCT 77	TEXAS INSTRUMENTS INCORPORATED Dallas Texas
			HOLE TOLERANCE 013 + .004 THRU - .001 125 - .001	251 + .006 THRU - .001 500 - .001	SCALE 2/1
			999689	8740	DRAWING NO 999780
			NEXT ASSY	USED ON	SIZE C 96214
			APPLICATION		SHEET

TI-9925H

4

3

2

LM 1

FORMED

LIST OF MATERIALS

DATE 10-24-77
P/N 0999780

Gear Assembly, Paper Advance

000 1
REV A

PRINT ITEM NUMBER	QUANTITY PER ASSEMBLY	PART NUMBER	DESCRIPTION
0001	00001.000	0999728-0001	GEAR, PAPER ADVANCE
0002	00001.000	0085936-0016	EYELET .121 BARREL OD X.156 LG FLANGE

6-123

NOTES UNLESS OTHERWISE SPECIFIED
 1. INSTALL INSULATOR (ITEM 2) TO GROUND PLANE (ITEM 1)
 2. INSTALL BUMPER (ITEM 3) TO GROUND PLANE (ITEM 1) USING POSITION HOLES IN INSULATOR (ITEM 2)

REV		DESCRIPTION		DATE	APPROVED
A	1	CN 445415	of 3 sp. in.	11-28-78	[Signature]
1) ADDED GROUND STRAP TO				PICTORIAL # Z B-7	

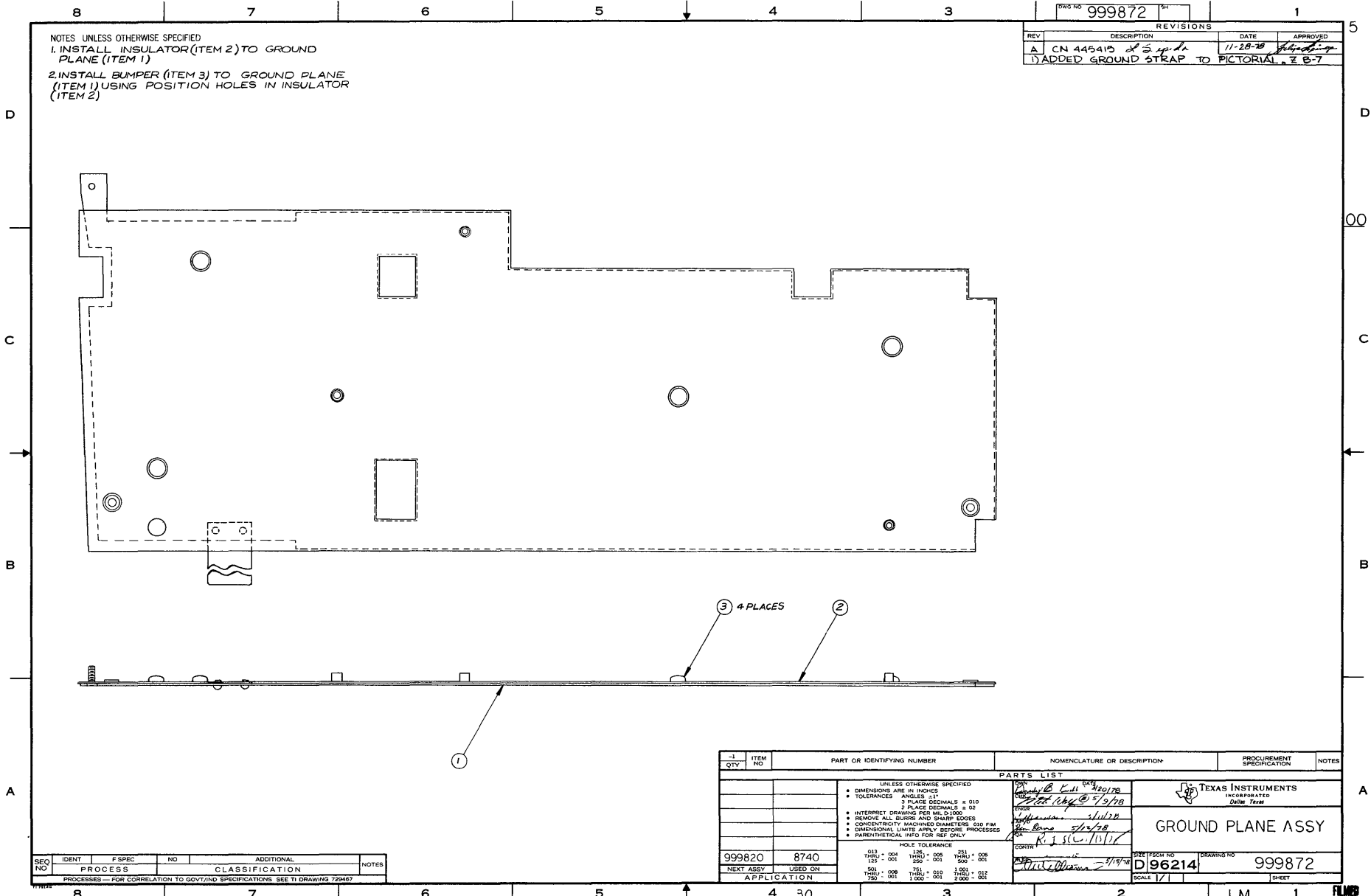

QTY	ITEM NO	PART OR IDENTIFYING NUMBER	NOMENCLATURE OR DESCRIPTION	PROCUREMENT SPECIFICATION	NOTES
PARTS LIST					
UNLESS OTHERWISE SPECIFIED * DIMENSIONS ARE IN INCHES * TOLERANCES - ANGLES ±1° 3 PLACE DECIMALS ± 0.10 2 PLACE DECIMALS ± 0.02 * INTERPRET DRAWING PER MIL-D-1000 * REMOVE ALL BURRS AND SHARP EDGES * CONCENTRICITY MACHINED DIAMETERS .010 FIM * DIMENSIONAL LIMITS APPLY BEFORE PROCESSES * PARENTHETICAL INFO FOR REF ONLY HOLE TOLERANCE .013 THRU .004 .125 ± .005 .251 ± .006 .125 - .001 .250 - .001 .500 - .001 .500 - .008 .751 ± .010 1.000 ± .012 .751 - .001 1.000 - .001 2.000 - .001					
999820	8740				
NEXT ASSY		USED ON		APPLICATION	

SEQ NO	IDENT	F SPEC	NO	ADDITIONAL	NOTES
	PROCESS			CLASSIFICATION	
PROCESSES - FOR CORRELATION TO GOVT/IND SPECIFICATIONS. SEE TI DRAWING 723467					

TEXAS INSTRUMENTS
 INCORPORATED
 Dallas Texas

GROUND PLANE ASSY

DATE: 11/28/78
 DRAWN BY: [Signature]
 CHECKED BY: [Signature]
 DATE: 12/12/78
 DATE: 5/14/78
 DATE: 3/15/77

SCALE: 1/1

SHEET FROM NO: D96214
 DRAWING NO: 999872
 SHEET: 1

LIST OF MATERIALS

DATE 10-31-78
P/N 0999872

Ground Plane Assembly

000 1
REV A

PRINT ITEM NUMBER	QUANTITY PER ASSEMBLY	PART NUMBER	DESCRIPTION
0001	00001.000	0999806-0001	PLATE, PC GROUND PLANE
0002	00001.000	0999805-0001	INSULATOR, GROUND PLANE
0003	00004.000	2210005-0003	BUMPER, RUBBER, ADHESIVE, GRAY

DWG NO 999829

NOTES: UNLESS OTHERWISE SPECIFIED
 1. INSTALL KEY (ITEM 4) IN POSITIONS
 P104-5 AND P106-2
 2. PIN 1 IDENTIFIER IS VENDOR NAME
 MOLDED INTO PART

WIRE NO	DESCRIPTION	SIGNATURE	START	FINISH	REMARKS	LM ITEM NO
1	WHITE	PDRV	MI-COIL 2	P106-1		1
2	YELLOW	PDRV	MI-COIL 1	P106-3		
3	YELLOW	PDRV	MI-COIL 2	P106-4		
4	WHITE	PDRV	MI-COIL 1	P106-5		
5	BLACK	PPHSA	MI-COIL 2	P104-1		
6	RED	PPH5B	MI-COIL 1	P104-2		
7	BLACK	PPH5D	MI-COIL 1	P104-3		
8	RED	PPH5C	MI-COIL 2	P104-4		
9	YELLOW/GREEN	GROUND	MI-SHIELD	TERM-1		13

REV	DESCRIPTION	DATE	APPROVED

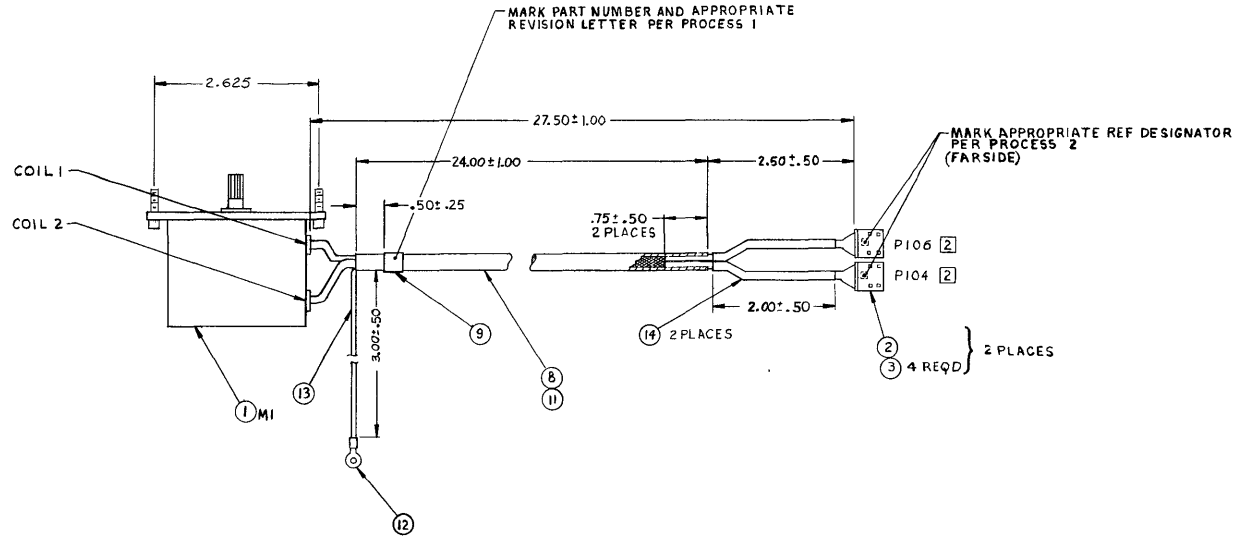

6-125

3	SLDR	127-01	00			
2	MARK	100-07	712		COLOR WHITE, TYPE 9	
1	MARK	100-07	712		COLOR BLACK, TYPE 6	
IDENT	F/PEC	NO	ADDITIONAL	CLASSIFICATION	NOTES	
PROCESS 1						

QTY	ITEM NO	PART OR IDENTIFYING NUMBER	NOMENCLATURE OR DESCRIPTION	PROCUREMENT SPECIFICATION	NOTES
2207421	8740				UNLESS OTHERWISE SPECIFIED • DIMENSIONS ARE IN INCHES • TOLERANCES: ANGLES ±1° 3 PLACE DECIMALS ± 010 2 PLACE DECIMALS ± 02 • INTERPRET DRAWING PER MIL-D-1000 • REMOVE ALL BURRS AND SHARP EDGES • CONCENTRICITY MACHINED DIAMETERS .010 FIM • DIMENSIONAL LIMITS APPLY BEFORE PROCESSES • PARENTHETICAL INFO FOR REF ONLY
2206573	8740				HOLE TOLERANCE SIZE 251 THRU + .006 112 - .001 250 - .001 500 - .001 501 - .006 751 + .010 1.001 + .012 750 - .001 1.000 - .001 2.000 - .001
APPLICATION		PARTS LIST DATE 7-16-77 NAME Steve Stinson 8-8-77 NAME Danie Hayes 8-8-77 NAME Dennis R. Lutzke 4/10/79 DATE 8/18/79 NAME [Signature] 8-28-77 NAME [Signature] 8/1/77		TEXAS INSTRUMENTS INCORPORATED Dallas, Texas MOTOR ASSEMBLY, PAPER DRIVE	
NEXT ASSY USED ON		SCALE 1/1		D96214 999829 DWG NO 999829 SCALE 1/1	

PROCESSES - FOR CORRELATION TO GOVT/IND SPECIFICATIONS SEE TI DRAWING 729467

8 7 6 5 4 3 2 1

LIST OF MATERIALS

DATE 07-30-79
P/N 0999829

Motor Assembly, Paper Drive

000 1
REV *

PRINT ITEM NUMBER	QUANTITY PER ASSEMBLY	PART NUMBER	DESCRIPTION
0001	00001.000	2206574-0001	MOTOR, STEPPING DR, W/PINTON (DUAL COIL)
0001A			MI
0002	00002.000	0972484-0005	CONNECTOR HOUSING 5 CONTACT
0002A			P104,P106
0003	00008.000	0972104-0001	CONTACT ELEC-LOCKING,WIRE-TO.025 SQ POST AMP
0004	00002.000	0996497-0001	KEYING PLUG CONNECTOR
0008	00002.100	0972436-0013	INSUL SLVG, .263DIA X .020 WALL THK PVC
0009	00001.000	0418201-0060	STRAP,MARKER,ADJUSTABLE,PLASTIC
0011	00002.100	0417371-0005	WIRE,BRAID,FLAT,.250 WIDE
0012	00001.000	2210066-0007	LUG,RING TONGUE,TAPE MTD,#6,22-16,RED
0013	00000.300	0996286-5455	WIRE,#18 B-18 19 STRANDS GRN/YEL
0014	00000.400	0972146-0004	TUBING,.020THK X 1/8 HT SHRINKABLE .125ID

DAY NO. 999738

NOTES UNLESS OTHERWISE SPECIFIED
 1 INSTALL KEY (ITEM 4) IN POSITION SHOWN
 2 USE KEY AS PIN 1 IDENTIFIER
 3. PIN P 101-6 IS NOT USED

WIRE NO	DESCRIPTION	SIGNATURE	START	FINISH	REMARKS	ITEM NO
1	YEL	RDRV	M-COIL 1	PIOI-4		1
2	YEL	RDRV	COIL 2	-3		1
3	WHT	RDRV	COIL 1	-2		1
4	WHT	RDRV	COIL 2	-5		1
5	RED	RPHSD	COIL 1	-3		1
6	BLK	RPHSC	COIL 2	-8		1
7	BLK	RPHSB	COIL 1	-7		1
8	RED	RPHSA	M-COIL 2	PIOI 10		1

REV	DESCRIPTION	DATE	APPROVED
A	CN 425872 LM UPDATE	10-26-77	<i>[Signature]</i>
B	CN 439790 R-P, i&e LM UPDATE	3-29-78	<i>[Signature]</i>
C	CN 432398 P/S LM UPDATE	2/11/78	<i>[Signature]</i>
D	CN 445454 CEA DA CHANGE WIRE LIST START COLUMN	11-28-78	<i>[Signature]</i>
E	CN 439649 S/P LM ITEM 8 P/1 WAS 972436-13	12-27-78	<i>[Signature]</i>
F	CN 437831 B/S, J/L ITEM 4 P/N 996997-1 WAS P/N 72591-1	8/11/79	<i>[Signature]</i>
G	CN 438073 REKHA SETH	4-28-79	<i>[Signature]</i>
H	ITEM 8 WAS PN 0972436-0035		

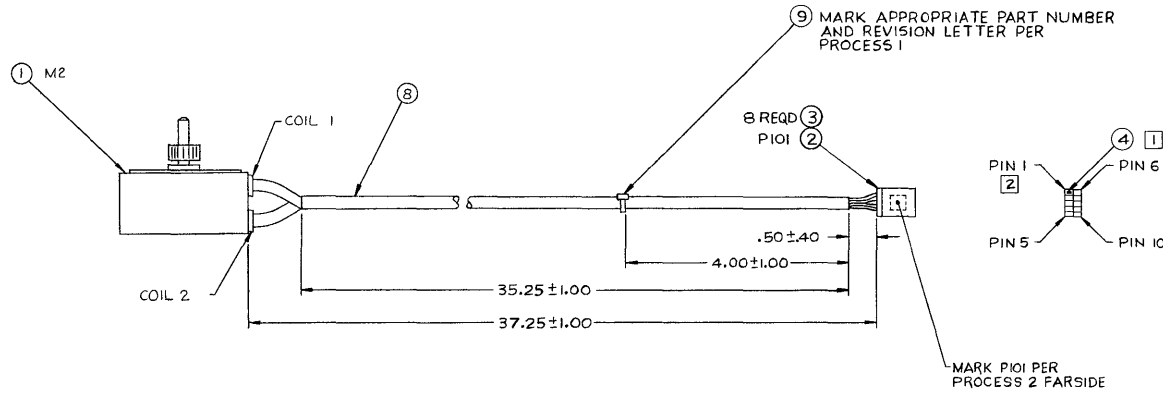

6-127

2 MARK	100-07	712	COLOR, WHT TYPE 9
1 MARK	100-07	712	COLOR, BLK TYPE 6
SEQ NO	IDENT	F SPEC	NO
	PROCESS		CLASSIFICATION
PROCESSES - FOR CORRELATION TO GOVT/IND SPECIFICATIONS SEE TI DRAWING 729467			

ITEM QTY	ITEM NO	PART OR IDENTIFYING NUMBER	NOMENCLATURE OR DESCRIPTION	PROCUREMENT PRECIFICATION	NOTES												
<p>UNLESS OTHERWISE SPECIFIED</p> <ul style="list-style-type: none"> DIMENSIONS ARE IN INCHES TOLERANCES ANGLES ±1° 3 PLACE DECIMALS ± 0.02 2 PLACE DECIMALS ± 0.03 INTERPRET DRAWING PER MIL 81300 REMOVE ALL BURRS AND SHARP EDGES CONCENTRICITY MACHINED DIAMETERS 0.10 FIM DIMENSIONAL LIMITS APPLY BEFORE PROCESSES PARENTHETICAL INFO FOR REF ONLY 																	
<p>999689 8740</p> <p>HOLE TOLERANCE</p> <table border="1"> <tr> <td>010 - 004</td> <td>120 - 005</td> <td>251 - 006</td> </tr> <tr> <td>125 - 001</td> <td>125 - 001</td> <td>1500 - 001</td> </tr> <tr> <td>501 - 008</td> <td>751 - 010</td> <td>1500 - 002</td> </tr> <tr> <td>750 - 001</td> <td>1000 - 001</td> <td>2000 - 001</td> </tr> </table>						010 - 004	120 - 005	251 - 006	125 - 001	125 - 001	1500 - 001	501 - 008	751 - 010	1500 - 002	750 - 001	1000 - 001	2000 - 001
010 - 004	120 - 005	251 - 006															
125 - 001	125 - 001	1500 - 001															
501 - 008	751 - 010	1500 - 002															
750 - 001	1000 - 001	2000 - 001															
<p>TEXAS INSTRUMENTS INCORPORATED Dallas Texas</p> <p>MOTOR ASSY, RIBBON DRIVE</p> <p>DATE 10-25-77</p> <p>BY <i>[Signature]</i> DATE 4/11/78</p> <p>CHKD <i>[Signature]</i> DATE 4/11/78</p> <p>APP'D <i>[Signature]</i> DATE 4/11/78</p> <p>DATE 4/11/78</p> <p>SIZE FROM NO DRAWING NO</p> <p>D 96214 999738</p> <p>SCALE 1/1</p>																	

TI 72644

LM

LIST OF MATERIALS

Motor Assembly, Ribbon Drive

DATE: 05-03-79
 P/N 0999738

000 1
 REV G

PRINT ITEM NUMBER	QUANTITY PER ASSEMBLY	PART NUMBER	DESCRIPTION
0001	00001.000	0999810-0001	MOTOR, STEPPING RIBBON DRIVE
0001A			M2
0002	00001.000	0996566-0005	HOUSING, CONN-10PDS SELF-RETAINING CONT
0002A			P101
0003	00008.000	0972104-0001	CONTACT ELEC-LOCKING, WIRE-TO.025 SQ POST ANP
0004	00001.000	0996497-0001	KEYING PLUG CONNECTOR
0008	00003.000	0972436-0036	INSUL SLVG, #4 PVC .208 ID .020THK
0009	00001.000	0418201-0049	STRAP, MARKER, ADJUSTABLE, PLASTIC

8

7

6

5

4

3

999732

1

NOTES UNLESS OTHERWISE SPECIFIED

- 1 CLEAN BOTH SURFACES TO BE BONDED WITH CLEAN ALCOHOL. APPLY SMALL AMOUNT OF ITEM 11 IN RECESS OF ITEM 2. PLACE ITEM 10 IN RECESS WITH A LONG SIDE ALIGNED PARALLEL TO ADJACENT SIDE OF RECESS. HOLD FIRMLY IN PLACE FOR 10 SECONDS. THERE MUST NOT BE ANY ADHESIVE IN HOLES OF ITEM 10 OR PROTRUDING ABOVE OUTSIDE SURFACES OF ITEM 10 OR 2.
- 2 INITIAL ADJUSTMENT IS ONE TURN BACK FROM FULLY SEATED ARMATURE (ITEM 19) POSITION.
- 3 GRIND NEEDLES SO THAT WITH SOLENOIDS ENERGIZED (.90 ± .05 AMPS) END OF NEEDLE IS .012 ± .001 BEYOND END OF ITEM 2.

- 4 ADJUST GAP ADJUSTMENT SCREW (ITEM 43) SUCH THAT WHEN SOLENOID COIL CURRENT IS REMOVED, END OF NEEDLE IS .0020 ± .0005 FROM END OF ITEM 2
- 5 MARK SITE/DATE CODE AND SERIAL NUMBER IN POSITION PER PARAGRAPHS 3.0 2.1 1.2 EM 1.2
- 6 TIGHTEN ITEM 24 UNIT. FLANGE OF ITEM 3 IS DEFORMED NOT LESS THAN WHEN THE TOP OF THE WASHER IS FLUSH WITH THE TOP OF THE FLANGE AND NOT MORE THAN V2 OF THE FLANGE THICKNESS

WIRE NO	DESCRIPTION	TOTAL LENGTH	SIGNATURE	START STATION	FINISH STATION	REMARKS	LM ITEM NO
1	COIL ASSEMBLY		SOLENOID 1	E 5	E 12		4
2				E 3	E 10		
3				E 7	E 14		
4				E 2	E 9		
5				E 4	E 11		
6				E 1	E 8		
7	COIL ASSEMBLY		SOLENOID 7	E 6	E 13		4

REV	DESCRIPTION	DATE	APPROVED
A	CN 439791 <i>John Brown</i>	4/14/78	<i>[Signature]</i>
B	CN 439742 <i>John Brown</i>	2-11-78	<i>[Signature]</i>
C	CN 440309 <i>John Brown</i>	8/15/78	<i>[Signature]</i>
D	CN 439895 <i>Duvkol</i>	11-10-78	<i>[Signature]</i>
E	CN 445009 <i>John Brown</i>	1/30/78	<i>[Signature]</i>
F	CN 445416 <i>John Brown</i>	1/17/78	<i>[Signature]</i>
G	CN 439612 <i>John Brown</i>	1/10/78	<i>[Signature]</i>
H	CN 445056 <i>John Brown</i>	5-19-78	<i>[Signature]</i>
J	CN 450926 (C) <i>John Brown</i>	7/17/78	<i>[Signature]</i>

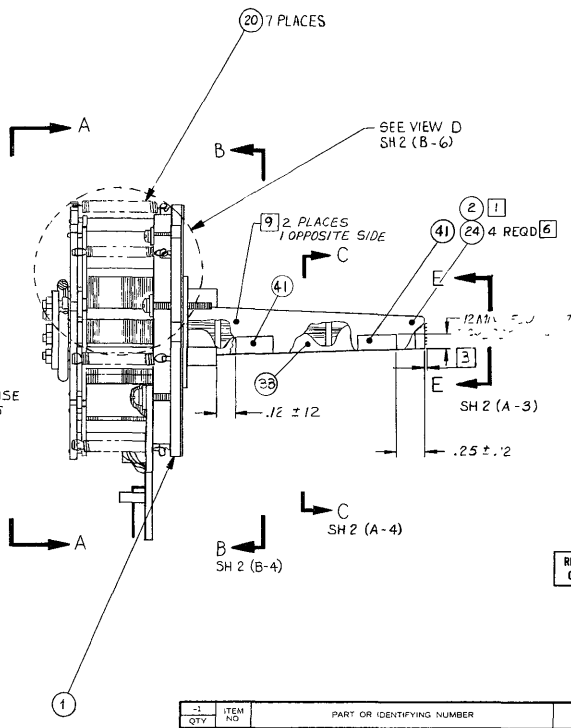
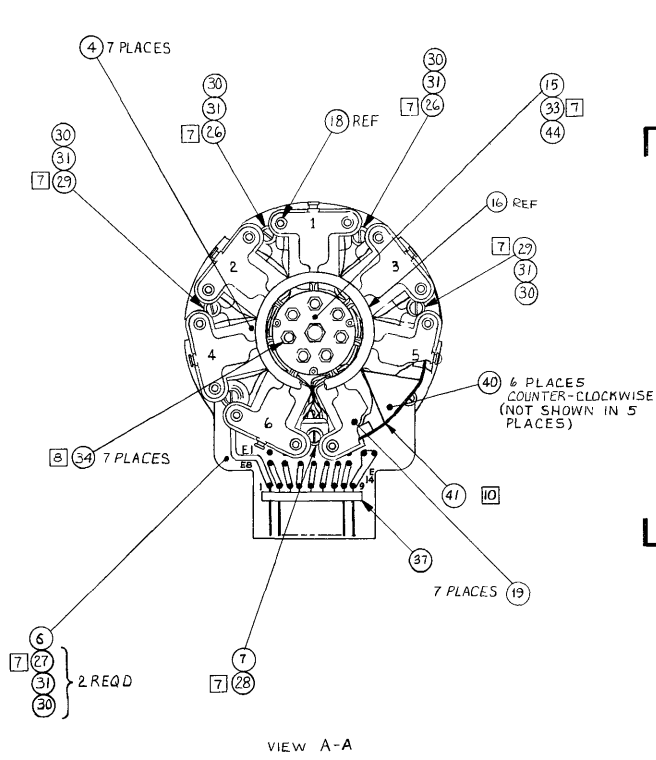

REV	J	J	
STATUS	SH	Z	

2	SLDR	127-01	00	
1	MARK	100-02	21	HEIGHT .12 COLOR BLACK 5,11
SEC NO	IDENT	F SPEC	NO	ADDITIONAL NOTES
	PROCESS			CLASSIFICATION

QTY	ITEM NO	PART OR IDENTIFYING NUMBER	NOMENCLATURE OR DESCRIPTION	PROCUREMENT SPECIFICATION	NOTES
		PARTS LIST		<p>UNLESS OTHERWISE SPECIFIED:</p> <ul style="list-style-type: none"> DIMENSIONS ARE IN INCHES TOLERANCES - ANGLES ± 1 3 PLACE DECIMALS = 0.001 2 PLACE DECIMALS = 0.005 1 PLACE DECIMALS = 0.010 INTERIOR DRAWING PER MIL D 1000 REMOVE ALL BURRS AND SHARP EDGES CONCENTRIC MOUNTED DIMETERS 0.010 FIN DIMENSIONAL LIMITS APPLY BEFORE PROCESSES PARENTHESES ARE FOR REF ONLY 	
1	999689	8740	SOLENOID ASSEMBLY		

TEXAS INSTRUMENTS
INCORPORATED
Dallas, Texas

PRINTHEAD ASSEMBLY,
30 VOLT

DRAWING NO. 999732
SCALE 2/1

SHEET 1 OF 2

6-129

8 7 6 5 4 3 2 1

- 7 TIGHTEN TO 6 ± 1 IN-LB
- 8 AFTER FINAL GAP ADJUSTMENT, TIGHTEN TO $2 \pm .5$ IN-LB
- 9 CLEAN SURFACES AS INDICATED WITH CLEAN ALCOHOL
- 10 TAPE (ITEM 41) TO BE WRAPPED AROUND ENTIRE PRINTHEAD WITH MIN. 2.00 IN OVERLAP, FOR PURPOSE OF SECURING ITEM 40
- 11 MARK "S/N" "P/N" AND APPROPRIATE PART NUMBER, "REV" AND APPROPRIATE REV LETTER IN POSITION PER PROCESS 1 ON ITEM 42
- 12 PROTRUDING SCREWS 3 PLACES MAY CAUSE UP TO .50 DIA OF ITEM 39 NOT TO STICK TO ITEM 1
- 13 CORNERS OF ITEM 42 WILL FOLD OVER DUE TO NOTCHES IN ITEM 1
- 14 WRAP A 3.00 \pm .25 LENGTH OF TAPE, ITEM 45, AROUND THE INDICATED PORTION OF THE REAR GUIDE, ITEM 3

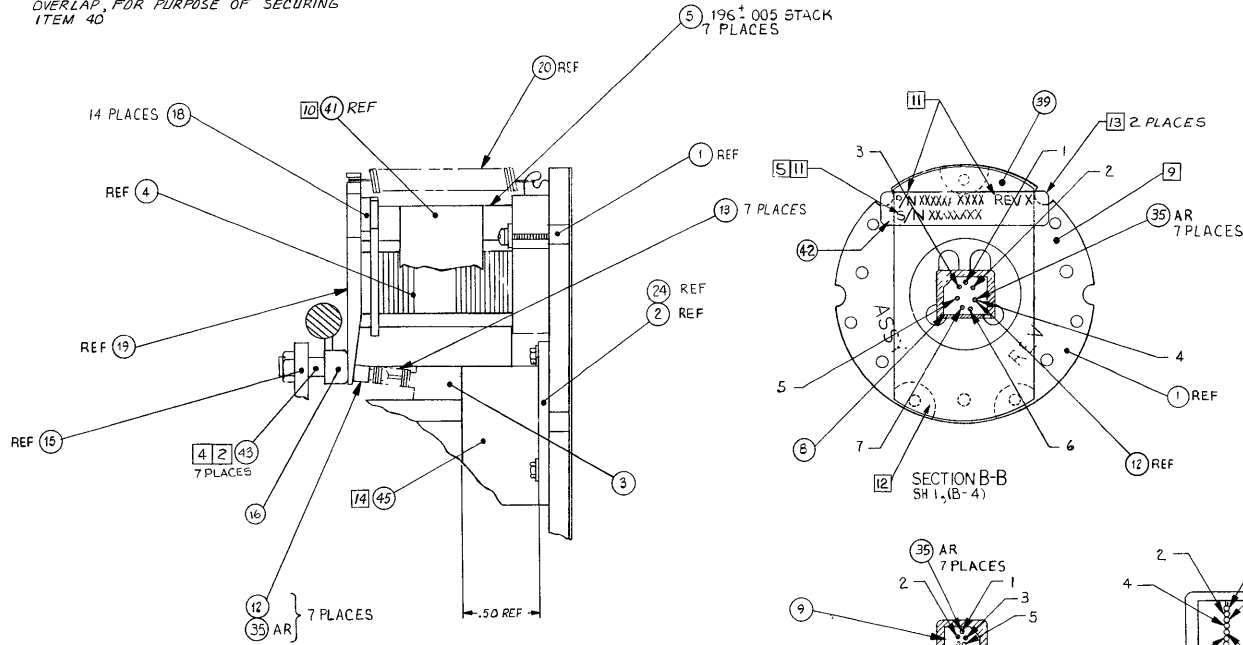

VIEW D
SCALE: NONE
SH 1, (C-3)

SECTION B-B
SH 1, (B-4)

SECTION C-C
SH 1, (B-4)

VIEW E-E
SCALE NONE
SH 1, (B-3)

6-130

SIZE	CODE IDENT NO	DRAWING NO	REV
D	96214	999732	J
SCALE 2/1		SHEET 2	

D 1999732

LIST OF MATERIALS

DATE 7-17-79
P/N 0999732

Printhead Assembly, 30 Volt

000 1
REV J

PRINT ITEM NUMBER	QUANTITY PER ASSEMBLY	PART NUMBER	DESCRIPTION
0001	00001.000	0994271-0001	PLATE, MOUNTING
0002	00001.000	0994295-0001	HOUSING, NEEDLE
0003	00001.000	0994280-0001	GUIDE, REAR
0004	00007.000	0999814-0001	COIL ASSY, 3V
0005	00350.000	0999815-0001	LAMINATION, SOLENOID
0006	00001.000	0999816-0001	PWB, PRINTHEAD, 9 CONDUCTOR
0007	00001.000	0994334-0001	SEPARATOR, WIRE
0008	00001.000	0994283-0001	BEARING, REAR
0009	00001.000	0994282-0001	BEARING, FRONT
0010	00001.000	0994332-0001	BEARING, JEWELLED
0011	AR	0996527-0002	ADHESIVE, LOCTITE 414 SUPER BONDER
0012	00007.000	0994274-0001	NEEDLE
0013	00007.000	0994278-0001	SPRING, NEEDLE
0015	00001.000	0994281-0001	DISC, ADJUSTMENT
0016	00001.000	0994494-0001	BUMPER, PRINTHEAD
0018	00014.000	0994276-0001	BUSHING
0019	00007.000	0994275-0001	ARMATURE
0020	00007.000	0994277-0001	SPRING, ARMATURE
0024	00004.000	0972679-0004	SCREW # 2-28 X 3/8 SLOTTED HEX
0026	00002.000	0972988-0014	SCREW 4-40 X .312 PAN HEAD CRES
0027	00002.000	0972988-0015	SCREW 4-40 X .375 PAN HEAD CRES
0028	00001.000	0972988-0016	SCREW 4-40 X .438 PAN HEAD CRES
0029	00002.000	0972988-0018	SCREW 4-40 X .625 PAN HEAD CRES
0030	00006.000	0416622-0011	WASHER #4 FLAT
0031	00006.000	0411104-0135	WASHER, LOCK-SPRING, HELICAL, #4
0032	AR	0996527-0003	ADHESIVE, CYANOACRYLATE, 420 SUPERBONDER
0033	00001.000	0972679-0009	SCREW #4-20 X 3/8" LG THD FORM, HEX
0034	00007.000	0416453-0019	NUT, PLAIN 2-56 UNC-2B HEX CRES, SMALL
0035	AR	0232573-0001	OIL #43 TERPRESTIC
0036	REF	0994396-9901	PROCEDURE, SITE & DATE CODE SERIALIZATION
0037	00001.000	0996865-0005	HEADER ASSY, 9 POS RIGHT ANGLE, .100
0038	00001.000	0999722-0001	INSULATOR, PRINTHEAD NOSE
0039	00001.000	0999723-0001	SOUNDFOIL, PRINTHEAD MOUNTING PLATE
0040	00006.000	0999755-0001	INSULATOR, SOUND PRINTHEAD
0041	AR	0411435-0012	TAPE, INSUL 3/8"W PRESS SENSITIVE TRANS
0042	00001.000	0232208-3500	LABEL WIRE MARKER DATABS VINYL CLOTH
0043	00007.000	0994524-0001	SET SCREW, BUMPER ADJUSTING PRINTHEAD
0044	AR	0417741-0001	COMPOUND, SEALING
0045	00000.250	0411435-0416	INSUL TAPE, ELEC, 1/2"W

8

7

6

5

4

3

DWG NO 999687

SHEET 1

1

NOTES UNLESS OTHERWISE SPECIFIED

1 APPLY 16 ± 1 IN-LBS TORQUE ON ITEM 31 AT ASSY

2 APPLY 5.5 ± 5 IN-LBS TORQUE ON ITEM 30 AT ASSY

3 MARK ASSY NO, APPROPRIATE REV LETTER, SITE/DATE CODE AND SERIAL NO PER ITEM 44, PARAGRAPH 3 AND MADE IN USA LOCATED APPROX AS SHOWN ON ITEM 43 USING BOTH STYLE LETTERS PER PROCESS 1

4 ITEM 28 MAY BE INSTALLED FROM EITHER SIDE OF ITEM 20 (SHOP OPTION)

REVISIONS			
REV	DESCRIPTION	DATE	APPROVED
A	LM UPDATES		
B	4.28745 10-7-77 & H. De Lora	10-11-77	H. De Lora
C	4.28957 11-3-77 & H. De Lora	11-3-77	H. De Lora
D	CHANGES TO ITEM 23 180° ROTATED MOTOR (ITEM 23) 180°	11/11/78	D. Steiner
E	CN 440399 P. 2. Working	1/10/78	D. Steiner
(1) DELETE ITEM 7 QTY 2 PIN 994306-1 (2) ITEM 43 WAS 991811-1 (3) NOTE 3 WAS MARK PART NO, APPROPRIATE REV LTR, SITE DATA CODE SERIAL NO PER ITEM 43 & 44 (4) SH 2 & B-7 DELETE PICTORIAL OF ITEM 7 MOVED ITEM 27 REF (5) REDREW VIEW C-C. SH 2 & B-3 WAS TAKEN FROM OPPOSITE SIDE. FRONT VIEW			
F	CN 439163 C. De Lora	3-24-79	D. Steiner
SH1 ZONE D-B NOTE 2 WAS APPLY B ± 1 IN LBS			

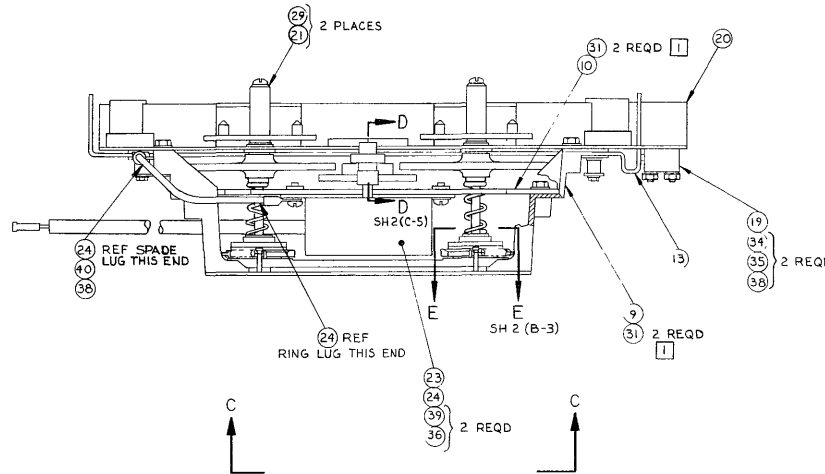
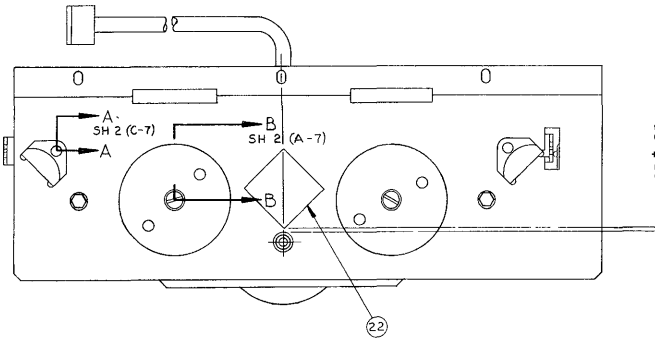

REV STATUS	REV	F	E
OF SHEETS	SH	1	2

ITEM QTY	ITEM NO	PART OR IDENTIFYING NUMBER	NOMENCLATURE OR DESCRIPTION	PROCUREMENT SPECIFICATION	NOTES
PARTS LIST					
UNLESS OTHERWISE SPECIFIED • DIMENSIONS ARE IN INCHES • TOLERANCES ANGLES ± 1 3 PLACE DECIMALS = .010 2 PLACE DECIMALS = .02 • INTERPRET DRAWING PER MIL-D-1000 • REMOVE ALL BURRS AND SHARP EDGES • CONCENTRICITY MACHINED DIAMETERS .010 FIM • DIMENSIONAL LIMITS APPLY BEFORE PROCESSES • PARENTHEUSAL INFO FOR REF ONLY					
HOLE TOLERANCE .013 ± .004 THRU .006 .145 ± .001 THRU .001 .501 ± .008 THRU .010 .750 ± .001 THRU 1.000					
999689 8740		DATE: 11/1/78 DRAWN: [Signature] CHECKED: [Signature] APPR: [Signature] DATE: 11/1/78		TEXAS INSTRUMENTS INCORPORATED DALLAS, TEXAS RIBBON DRIVE	
NEXT ASSY USED ON		D96214		DRAWING NO 999687	
APPLICATION		SHEET 1/1		SHEET 1 OF 2	

1	MARK 100	HEIGHT .10 COLOR BLK	5
SEQ NO	IDENT	F SPEC	NO
PROCESS		CLASSIFICATION	
PROCESSES — FOR CORRELATION TO GOVT/IND SPECIFICATIONS SEE IT DRAWING 72487			

6-132

LM 1 FILMED

8 7 6 5 4 3 2 1

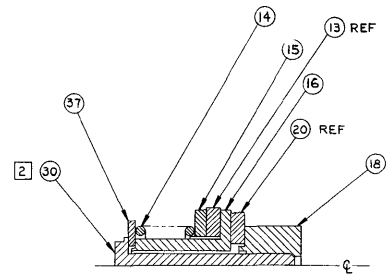

SECTION A-A
2 PLACES
(1 OPP HAND)
SCALE: 4/1
SH 1 (C-7)

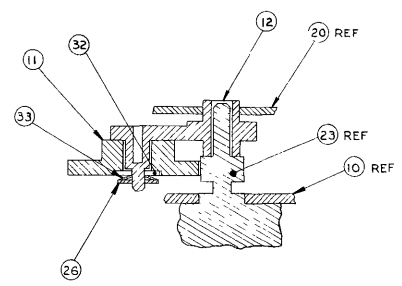

SECTION D-D
SCALE: 2/1
SH 1 (B-6)

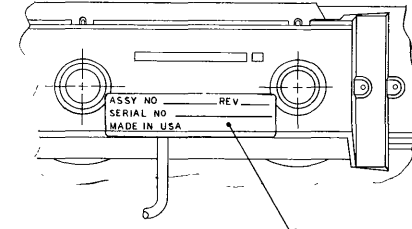
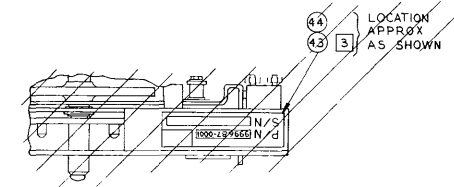

VIEW C-C
SH 1 (A-6)

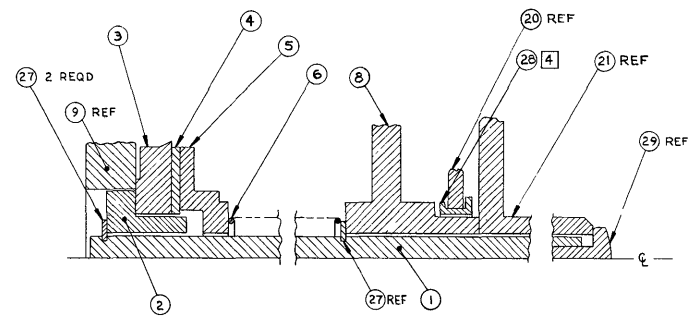

SECTION B-B
2 PLACES
SCALE: 4/1
SH 1 (C-7)

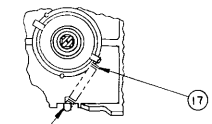

SECTION E-E
2 PLACES
(1 OPP HAND)
SH 1 (B-6)

6-133

8 7 6 5 4 3 2 1

LIST OF MATERIALS

DATE 02-28-79
P/N 999687

Ribbon Drive Assembly

000 1
REV F

PRINT ITEM NUMBER	QUANTITY PER ASSEMBLY	PART NUMBER	DESCRIPTION
0001	00002.000	0994216-0001	SHAFT, DRIVE-RIBBON
0002	00002.000	0994217-0001	BEARING, LOWER-RIBBON
0003	00002.000	0994218-0001	DISK, FRICTION-RIBBON
0004	00002.000	0994219-0001	PAD, FRICTION-RIBBON
0005	00002.000	0994220-0001	HUB, PRESSURE-RIBBON
0006	00002.000	0994221-0001	SPRING, COMPRESSION-GEAR DRIVE
0008	00002.000	0994222-0001	GEAR, DRIVE RIBBON
0009	00001.000	0999696-0001	CHASSIS, RIBBON DRIVE
0010	00001.000	0999699-0001	PLATE, RIBBON MOTOR
0011	00001.000	0999700-0001	GEAR, IDLER/REVERSE-MTR
0012	00001.000	0999701-0001	ARM, REVERSE-MTR
0013	00001.000	0994227-0001	ARM, SHIFT-RIBBON
0014	00002.000	0994228-0001	SPRING, COMPRESSION-SHIFT ARM
0015	00002.000	0994230-0001	WASHER, THRUST-SHIFT ARM
0016	00002.000	0994285-0001	BEARING, SHIFT ARM
0017	00002.000	0994355-0001	SPRING, EXTENSION-RIBBON TAKEUP
0018	00002.000	0994377-0001	GUIDE, RIBBON-SPOOL
0019	00001.000	0996754-0001	SWITCH, 1 AMP 30VDC MINI SENSITIVE
0020	00001.000	0999702-0001	PLATE, TOP
0021	00002.000	0994290-0001	HUB, DRIVE-RIBBON
0022	00001.000	0994496-0001	PAD, STATIC GROUND- FOAM
0023	00001.000	0999738-0001	MOTOR ASSY, RIBBON DRIVE
0024	00001.000	0960967-0003	LEAD, ELECTRICAL-GND
0026	00001.000	0412991-0003	RING #4 PRONGS RETAINING EXTERNAL
0027	00004.000	0416402-4018	RING, RETAINING EXTERNAL "E"
0028	00002.000	0230033-0001	BEARING SNAP-IN NYLON
0029	00002.000	0972988-0027	SCREW 6-32 X .312 PAN HEAD CRES
0030	00002.000	0972679-0026	SCREW THREAD SLOTTING HEX .750
0031	00004.000	0972679-0013	SCREW # 6-19 X 1/2 SLOTTED HEX
0032	00001.000	0411027-0806	WASHER .156 X .375 X .049 FLAT CRES
0033	00001.000	0996277-0001	WASHER, SPRING, #5
0034	00002.000	0416622-0011	WASHER #4 FLAT
0035	00002.000	0411104-0135	WASHER, LOCK-SPRING, HELICAL, #4
0036	00002.000	0411101-0058	LOCKWASHER #6 EXTERNAL TOOTH CRES
0037	00002.000	0411027-0807	WASHER .188 X .375 X .049 FLAT CRES
0038	00003.000	0416453-0021	NUT, PLAIN, 4-40 UNC-2B HEX, CRES, SMALL
0039	00002.000	0972988-0028	SCREW 6-32 X .375 PAN HEAD CRES
0040	00001.000	0411101-0057	LOCKWASHER # 4 EXTERNAL TOOTH CRES
0043	00001.000	0232208-7000	LABEL 1X3INS RECTL SELF-ADHESIVE
0044	REF	0994396-9901	PROCEDURE, SITE & DATE CODE SERIALIZATION

LIST OF MATERIALS

DATE 02-28-79
P/N 999687

Ribbon Drive Assembly

800 1
REV F

PRINT ITEM NUMBER	QUANTITY PER ASSEMBLY	PART NUMBER	DESCRIPTION
0001	00001.000	0999687-0001	RIBBON DRIVE

DATE 02-28-79
P/N 999687

Ribbon Drive Assembly

000 1
REV _____

PRINT ITEM NUMBER	QUANTITY PER ASSEMBLY	PART NUMBER	DESCRIPTION
0001	00001.000	0999810-0001	MOTOR, STEPPING RIBBON DRIVE
0001A			M2
0002	00001.000	0996566-0005	HOUSING, CONN-10POS SELF-RETAINING CONT
0002A			P101
0003	00008.000	0972104-0001	CONTACT ELEC-LOCKING, WIRE-TO-.025 SQ POST AMP
0004	00001.000	0996497-0001	KEYING PLUG CONNECTOR
0008	00003.000	0972436-0036	INSUL SLVG, #4 PVC .208 ID .020THK
0009	00001.000	0418201-0060	STRAP, MARKER, ADJUSTABLE, PLASTIC

NOTES UNLESS OTHERWISE SPECIFIED

REV	DESCRIPTION	DATE	APPROVED
A	CN 425081 8/16/78 D SHARNEK LM UPDATE - DELETE ITEM 11	16 AUG 78	[Signature]
B	CN 436365 7/7 August 78-78 DESS CNG (1) ITEM 8 AND 78AM STAIRS-ONE (1) ITEM 3 WAS 78AM STAIRS-CUTTER + HOSES FOR STAIRS OF SHEETS BOOK	7/27/78	[Signature]
C	CN 448472 7/11 August 78-78 ADDED ITEM 16 TO LM (2) SH 2 (F-R) BALLOON IS WAS 5	11/20/78	[Signature]
D	CN 451058 2-3-78 W/ [Signature]	2/3/78	[Signature]
E	CN 451058 2-3-78 W/ [Signature]	2/3/78	[Signature]
F	CN 451058 2-3-78 W/ [Signature]	2/3/78	[Signature]
G	CN 451058 2-3-78 W/ [Signature]	2/3/78	[Signature]
H	CN 451058 2-3-78 W/ [Signature]	2/3/78	[Signature]
I	CN 451058 2-3-78 W/ [Signature]	2/3/78	[Signature]
J	CN 451058 2-3-78 W/ [Signature]	2/3/78	[Signature]
K	CN 451058 2-3-78 W/ [Signature]	2/3/78	[Signature]
L	CN 451058 2-3-78 W/ [Signature]	2/3/78	[Signature]
M	CN 451058 2-3-78 W/ [Signature]	2/3/78	[Signature]
N	CN 451058 2-3-78 W/ [Signature]	2/3/78	[Signature]
O	CN 451058 2-3-78 W/ [Signature]	2/3/78	[Signature]
P	CN 451058 2-3-78 W/ [Signature]	2/3/78	[Signature]
Q	CN 451058 2-3-78 W/ [Signature]	2/3/78	[Signature]
R	CN 451058 2-3-78 W/ [Signature]	2/3/78	[Signature]
S	CN 451058 2-3-78 W/ [Signature]	2/3/78	[Signature]
T	CN 451058 2-3-78 W/ [Signature]	2/3/78	[Signature]
U	CN 451058 2-3-78 W/ [Signature]	2/3/78	[Signature]
V	CN 451058 2-3-78 W/ [Signature]	2/3/78	[Signature]
W	CN 451058 2-3-78 W/ [Signature]	2/3/78	[Signature]
X	CN 451058 2-3-78 W/ [Signature]	2/3/78	[Signature]
Y	CN 451058 2-3-78 W/ [Signature]	2/3/78	[Signature]
Z	CN 451058 2-3-78 W/ [Signature]	2/3/78	[Signature]

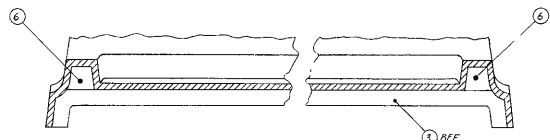

SECTION A-A
SH1 (D-7)
ROTATED 90° CW

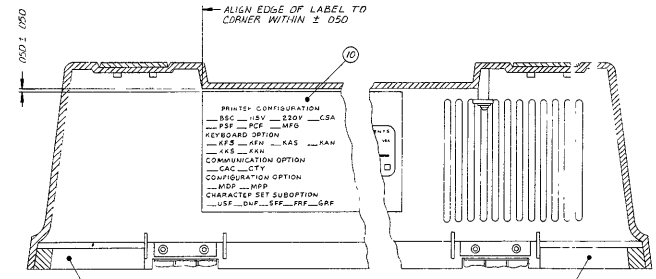

SECTION B-B
SH1 (F-7)
ROTATED 90° CW

- PRINTER CONFIGURATION
- BSC — ISV — E207 — CSA
 - P3F — PCF — MFD
 - KEYBOARD OPTION
 - KPS — AEN — KAS
 - KAS — RAN
 - COMMUNICATION OPTION
 - CAC — CTV
 - CONFIGURATION OPTION
 - MSP — MFP
 - CHARACTER SET SUBOPTION
 - USF — GVF — SFF — PFF — GAF

REV STATUS	REV	C	Q
OF SHEETS	SH	1	2

6-136

REV	IDENT	PROCESS	NO	ADDITIONAL	NOTES
1					

ITEM NO.	PART OR IDENTIFYING NUMBER	NOMENCLATURE OR DESCRIPTION	QUANTITY	REVISIONS	NOTES
999690	8740	COVER ASSY	1	1	

UNLESS OTHERWISE SPECIFIED

- DIMENSIONS ARE IN INCHES
- TOLERANCES UNLESS NOTED
- FINISH: 12-1/2
- SURFACE: 12-1/2
- DIMENSIONS UNLESS NOTED
- DIMENSIONS UNLESS NOTED
- DIMENSIONS UNLESS NOTED
- DIMENSIONS UNLESS NOTED

TEXAS INSTRUMENTS
CORPORATION
DALLAS, TEXAS

999918

1 OF 2

6-137

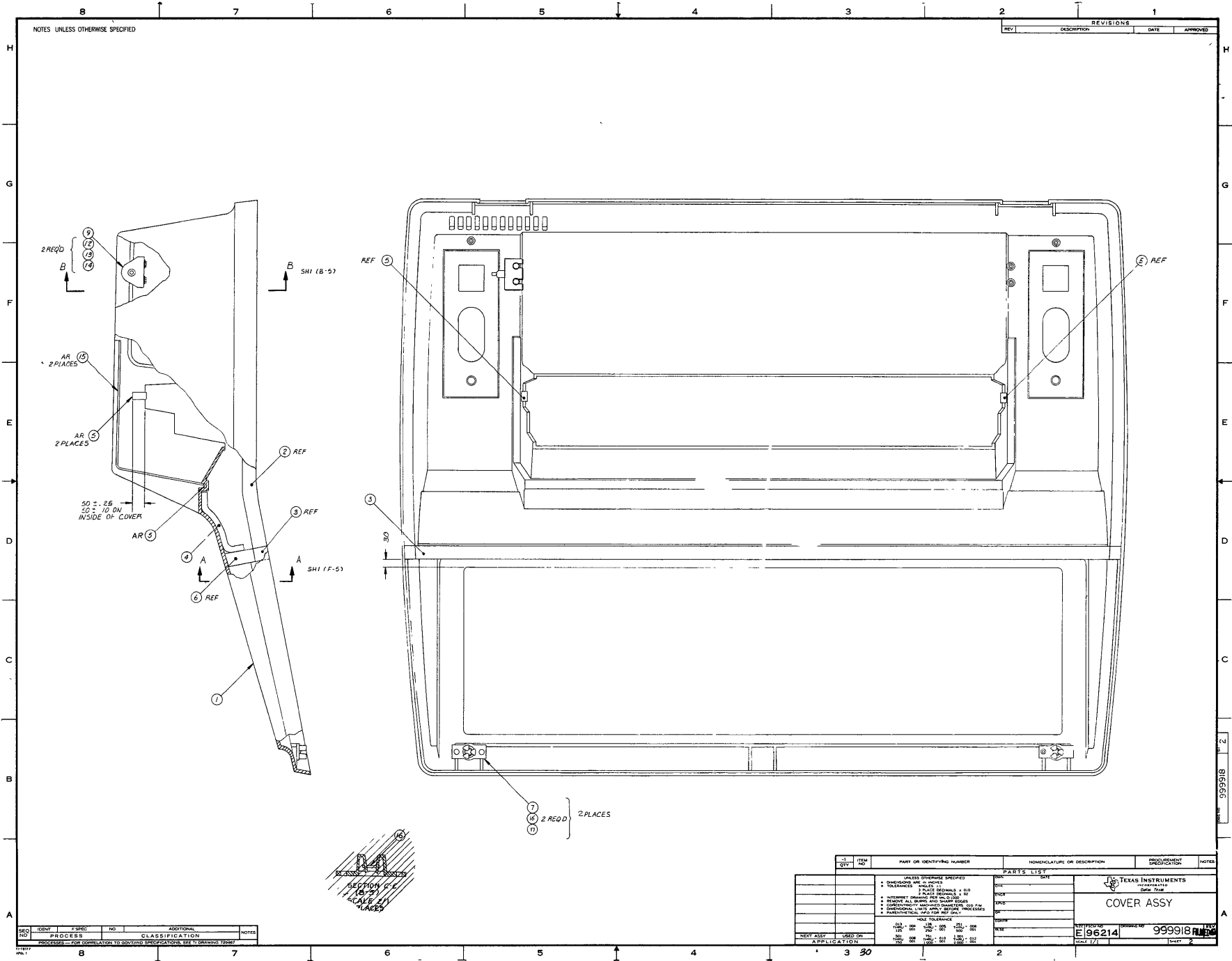

REVISIONS		
REV	DESCRIPTION	DATE

NOTES: UNLESS OTHERWISE SPECIFIED

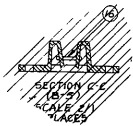

QTY	ITEM NO	PART OR IDENTIFYING NUMBER	MANUFACTURE OR DESCRIPTION	PROCUREMENT SPECIFICATION	NOTES

REV	QTY	PROCESS	DATE	NO.	CLASSIFICATION	ADDITIONAL	NOTES

TEXAS INSTRUMENTS

 COVER ASSY

 E196214

 999918

 SHEET 2

LIST OF MATERIALS

DATE 6-14-79
P/N 099918

Cover Assembly

000 1
REV G

PRINT ITEM NUMBER	QUANTITY PER ASSEMBLY	PART NUMBER	DESCRIPTION
0001	00001.000	0999707-0001	COVER, TERMINAL
0002	00002.000	0999914-0001	INSULATOR, ACOUSTICAL, COVER-SIDE
0003	00001.000	0999914-0002	INSULATOR, ACOUSTICAL, COVER-CENTER
0004	00001.000	0999754-0001	INSULATOR, SOUND COVER - TOP
0005	AR	0972361-0006	TAPE, FOAM, VINYL, .06THK .25WIDE SELF ADH
0006	00002.000	0999908-0001	PLUG, COVER
0007	00002.000	0999757-0001	CATCH, COVER
0009	00001.000	0999751-0001	STAY PLATE, TOP
0010	00001.000	0999834-0001	LABEL, INSTRUCTION PAPER & RIBBON LOADING
0012	00002.000	0972988-0031	SCREW 6-32 X .625 PAN HEAD CRES
0013	00002.000	0416622-0013	WASHER #6 FLAT
0014	00002.000	0996797-0002	NUT, 6-32, .309-.31500 .116-.120ID SH SPR
0015	AR	0972361-0008	TAPE, FOAM, VINYL, SELF-ADH .75W X .06THK
0016	00004.000	0416622-0020	WASHER, FLAT .105 ID X .250 OD X .016 THK
0017	00004.000	0972679-0002	SCREW # 2-28 X .250 THREAD, SLOTTING HEX

4

3

2

1

2

D

00

C

5

999925

A

LM

FILMED

NOTES, UNLESS OTHERWISE SPECIFIED

- 1 CABLE CLAMP SCREW AND RETAINER CLIPS AND SCREWS INCLUDED WITH ITEM 1
- 2 RETAINER CLIP INSTALLED WITH THREADED HOLE ON SAME SIDE AS SCREW HEAD
- 3 SCREWS MUST BE THREADED COMPLETELY THRU RETAINER CLIP

REVISIONS			
REV	DESCRIPTION	DATE	APPROVED
A	CN 451069	JR Young 3-10-79	D. Starn
(1) L/M PN WAS 999925-8001			

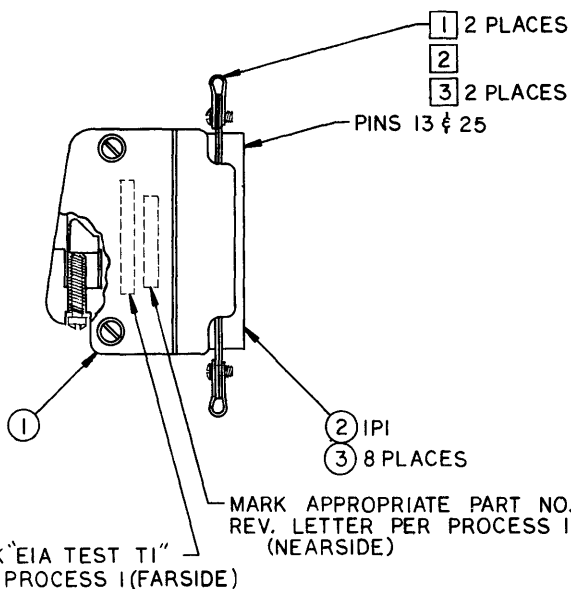

WIRE NO.	DESCRIPTION	TOTAL LENGTH	SIGNATURE	START STA.	FINISH STA.	REMARKS	ITEM NO.
1	22AWG 1PVC WHITE	3.0	BA/103 TO BB/104	IPI-2	IPI-3	JUMPER	4
2	22AWG 1PVC WHITE	3.0	CD/108 TO CC/107	IPI-20	IPI-6	JUMPER	4
3	22AWG 1PVC WHITE	3.0	CA/105 TO CB/106	IPI-4	IPI-5	JUMPER	4
4	22AWG 1PVC WHITE	3.0	SCA/118 TO CF/109	IPI-11	IPI-8	JUMPER	4

-1 QTY	ITEM NO	PART OR IDENTIFYING NUMBER	NOMENCLATURE OR DESCRIPTION	PROCUREMENT SPECIFICATION	NOTES
PARTS LIST					
UNLESS OTHERWISE SPECIFIED • DIMENSIONS ARE IN INCHES • TOLERANCES ANGLES ±1° 3 PLACE DECIMALS = 010 2 PLACE DECIMALS = 02 • INTERPRET DRAWING PER MIL-D-1000 • REMOVE ALL BURRS AND SHARP EDGES • CONCENTRICITY MACHINED DIAMETERS .010 FIM • DIMENSIONAL LIMITS APPLY BEFORE PROCESSES • PARENTHEetical INFO FOR REF ONLY					
999853	8740		DWN DATE 2-21-78 J. R. Young 9/1/78 J. R. Young 9/1/78 J. R. Young 9/1/78 J. R. Young 9/1/78	TEXAS INSTRUMENTS INCORPORATED Dallas, Texas	
TEST PLUG, 820 EIA				SIZE FSCM NO	DRAWING NO
NEXT ASSY USED ON APPLICATION				C 96214	999925
SCALE NONE				SHEET	

SEQ NO	IDENT	F-SPEC	NO	ADDITIONAL CLASSIFICATION	NOTES
1	MARK	100-07	712	COLOR WHT. TYPE 9	

PROCESSES — FOR CORRELATION TO GOVT/IND SPECIFICATIONS, SEE TI DRAWING 729467

4

3

30

2

1

LM

FILMED

6-139

999925

TI 9925H

LIST OF MATERIALS

DATE 02-28-79
P/N 0999925

Test Plug, 820 EIA

000 1
REV A

PRINT ITEM NUMBER	QUANTITY PER ASSEMBLY	PART NUMBER	DESCRIPTION
0001	00001.000	0539903-0004	HOOD, CONN 37 PIN
0002	00001.000	0539409-0005	CONNECTOR, PLUG 25 PINS
0002A			1P1
0003	00008.000	0539430-0003	CONTACT, PIN 24-20AWG .068 INSUL DIA
0004	00001.000	0538347-3999	WIRE HOOKUP 8-22 AWG 19 STR WHITE

993205

REV		DESCRIPTION		DATE	APPROVED
A	1	415775 (L)	Rev. 11/2/76	11/2/76	[Signature]

REV PER ENGR MARKUP
FORMAL RELEASE

WIRE NO.	DESCRIPTION	START STATION	FINISH STATION	SIGNATURE	ITEM NO	REMARKS
1	22 AWG-CABLE-BLK	P1-1	P2-1	AA	5	
2	-WHT	-2	-2	BA		
3	-RED	-3	-3	BB		
4	-CRN	-4	-4	CA		
5	-BRN	-5	-5	CE		
6	-BLU	-6	-6	CC		
7	-ORN	-7	-7	AB		
8	-YEL	8	8	CF		
9	-VIO	-11	-11	SCA		
10	-GRY	-12	-12	SCF		
11	-PINK	-20	-20	CD		
12	22 AWG-CABLE-TAN	P1-22	P2-22	CE	2	

- NOTES UNLESS OTHERWISE SPECIFIED
- CABLE CLAMP SCREWS & RETAINER CLIPS & SCREWS INCLUDED WITH ITEM 2
 - RETAINER CLIP INSTALLED WITH THREADED HOLE ON SAME SIDE AS SCREW HEAD
 - SCREWS MUST BE THREADED COMPLETELY THRU RETAINER CLIPS

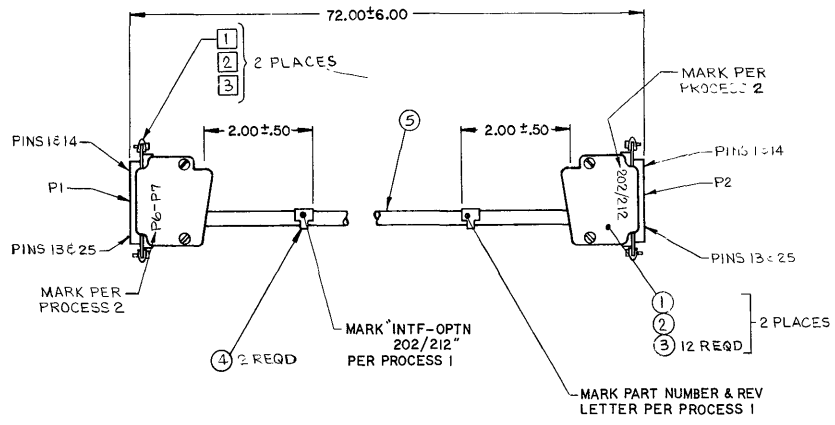

1	ITEM NO	PART OR IDENTIFYING NUMBER	NOMEN. A. R. M. U. C. R. I. T. I. O. N.	PROUREMENT SPECIFICATION	NOTES																								
PARTS LIST																													
UNLESS OTHERWISE SPECIFIED																													
• DIMENSIONS ARE IN INCHES																													
• TOLERANCES UNLESS SHOWN OTHERWISE:																													
• FRACTIONS: ±.01																													
• DECIMALS: ±.0005																													
• ANGLES: ±.0001																													
• HOLE TOLERANCE: ±.0005																													
• UNLESS OTHERWISE SPECIFIED:																													
• DIMENSIONS ARE IN INCHES																													
• TOLERANCES UNLESS SHOWN OTHERWISE:																													
• FRACTIONS: ±.01																													
• DECIMALS: ±.0005																													
• ANGLES: ±.0001																													
• HOLE TOLERANCE: ±.0005																													
• UNLESS OTHERWISE SPECIFIED:																													
• DIMENSIONS ARE IN INCHES																													
• TOLERANCES UNLESS SHOWN OTHERWISE:																													
• FRACTIONS: ±.01																													
• DECIMALS: ±.0005																													
• ANGLES: ±.0001																													
• HOLE TOLERANCE: ±.0005																													
993104	8744																												
993102	8744																												
NEXT ASST USED ON APPLICATION																													
<table border="1"> <tr> <td>100</td> <td>100</td> <td>100</td> <td>100</td> <td>100</td> <td>100</td> </tr> <tr> <td>101</td> <td>101</td> <td>101</td> <td>101</td> <td>101</td> <td>101</td> </tr> <tr> <td>102</td> <td>102</td> <td>102</td> <td>102</td> <td>102</td> <td>102</td> </tr> <tr> <td>103</td> <td>103</td> <td>103</td> <td>103</td> <td>103</td> <td>103</td> </tr> </table>						100	100	100	100	100	100	101	101	101	101	101	101	102	102	102	102	102	102	103	103	103	103	103	103
100	100	100	100	100	100																								
101	101	101	101	101	101																								
102	102	102	102	102	102																								
103	103	103	103	103	103																								
<p>TEXAS INSTRUMENTS INCORPORATED Dallas Texas</p> <p>CABLE ASSY 202/212 DATA SET</p>				<p>993205</p>																									
<p>SCALE: NONE</p>				<p>REV: A</p>																									

2	MARK	100-07	712	COLOR WHITE, TYPE 9
1	MARK	100-07	712	COLOR BLACK, TYPE 6
SEQ NO	IDENT	FSPEC	NO	ADDITIONAL
CLASSIFICATION				
NOTES				

PROCESSES - FOR CORRELATION TO GOVT/IND SPECIFICATIONS, SEE TI DRAWING 72449

6-141

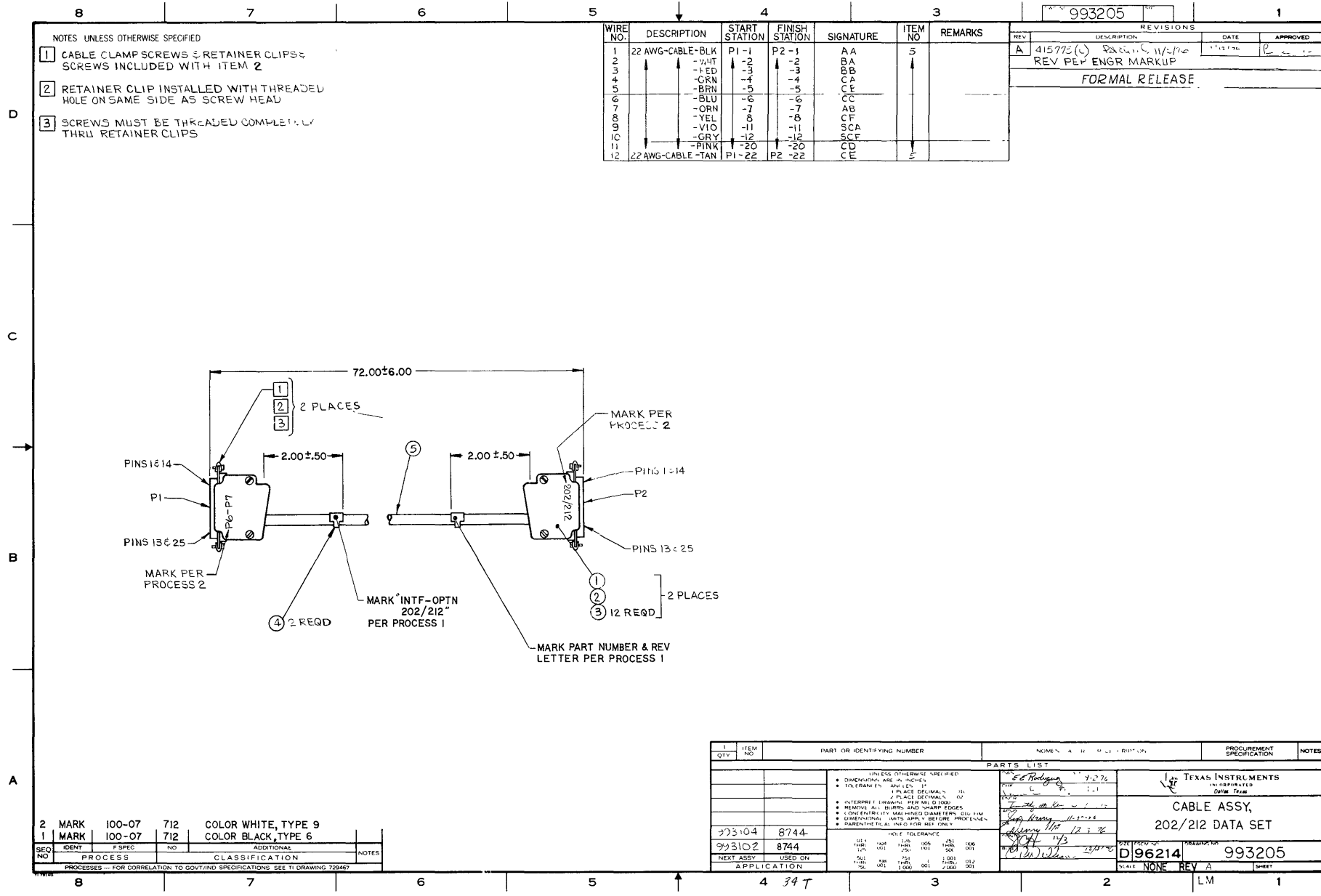

LIST OF MATERIALS

DATE 12-1-76
P/N 993205

Cable Assembly, 202/212 Data Set

000 1
REV A

PRINT ITEM NUMBER	QUANTITY PER ASSEMBLY	PART NUMBER	DESCRIPTION
0001	00002.000	0539409-0005	CONNECTOR, PLUG 25 PINS
0002	00002.000	0539903-0001	HOOD, CUNN 25 PIN WITH RETAINERS
0003	00024.000	0539430-0003	CONTACT, PIN 24-20AWG .068 INSUL DIA
0004	00002.000	0418201-0060	STRAP, MARKER, ADJUSTABLE, PLASTIC
0005	00006.500	0972444-0005	CABLE, 12COND 22AWG UL LISTED
0006	REF	0983404-9901	TEST PGM, 202/212 DATA SET CABLE-OMNI

4

3

2

1

NOTES, UNLESS OTHERWISE SPECIFIED

- 1 INSTALL KEY (ITEM 3) IN POSITION PI05-3
- 2 POSITION PI05-4 IS NOT USED
- 3 PIN 1 IDENTIFIER IS VENDOR NAME MOLDED INTO PART
- 4 INSTALL TUBING (ITEM 12) TO DRAIN WIRE BEFORE INSTALLING TERM LUG (ITEM 10)

WIRE NO	TOT LG	DESCRIPTION	SIGNATURE	START STA	FINISH STA	REMARKS	LM ITEM NO
1	AR	CLEAR	CMTRA	PI05-1	TERM1	SPLY	7
2	AR	BLACK	CMTRB	PI05-2	TERM2	RETRN	7
3	AR	DRAIN	GND	-	TERM3	GND	7

REVISIONS			
REV	DESCRIPTION	DATE	APPROVED
A	CN 439797 <i>Pf...</i>	4/13/78	<i>TRW</i>
LM UPDATES			
B	CN 440310 J. CLARK	8-17-78	<i>J. Clark</i>
1) LM: 11.7 PIN WAS 230252-3 "DESCRIPTION CABLE 20 2COND POLY BEDFOIL"			
2) F/D: TWO 22 AWG (2B-3) WAS TWO 20 AWG"			
C	CN 439655 <i>J. Clark</i>	4/28/78	<i>J. Clark</i>
1) ZNC-3 DIM 5.00 ± 1.00 WAS 8.00 ± 2.00			
D	CN 437830 <i>B. ...</i>	4/11/79	<i>B. ...</i>
ITEM 3 PN 996447-1 WAS PN 972549-1			

MARK PIN & APPROPRIATE REV LETTER PER PROCESS 1

MARK PI05 FAR SIDE PER PROCESS 2

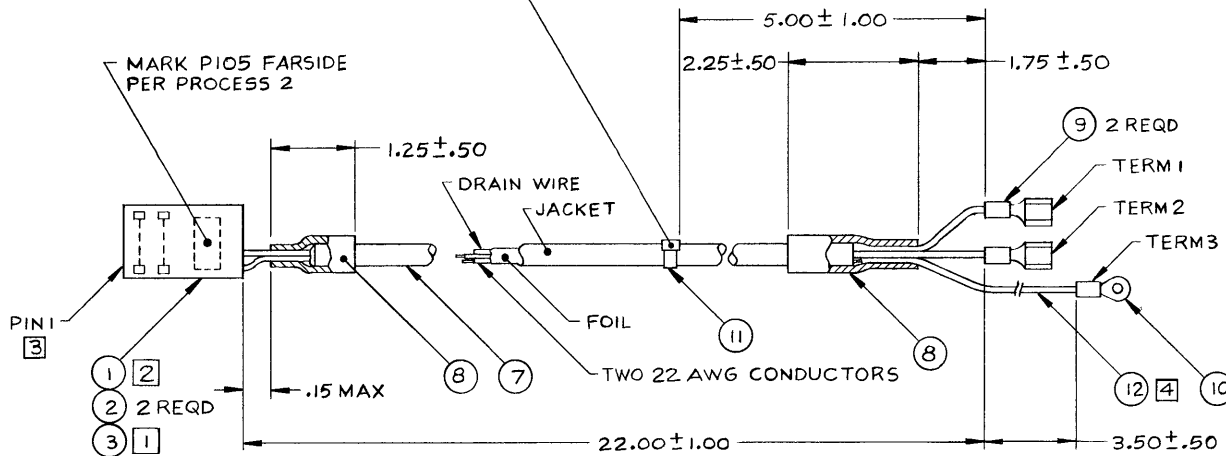

6-143

999736

2	MARK	100-07	712	COLOR WHITE, TYPE 9	
1	MARK	100-07	712	COLOR BLACK, TYPE 6	
SEQ NO	IDENT	F.SPEC	NO	ADDITIONAL	NOTES
PROCESS		CLASSIFICATION			

QTY	ITEM NO	PART OR IDENTIFYING NUMBER	NOMENCLATURE OR DESCRIPTION	PROCUREMENT SPECIFICATION	NOTES
PARTS LIST					
UNLESS OTHERWISE SPECIFIED					
• DIMENSIONS ARE IN INCHES					
• TOLERANCES ANGLES - 1°					
3 PLACE DECIMALS - 010					
2 PLACE DECIMALS - 02					
• INTERPRET DRAWING PER MIL-D-1000					
• REMOVE ALL BURRS AND SHARP EDGES					
• CONCENTRICITY MACHINED DIAMETERS .010 FIM					
• DIMENSIONAL LIMITS APPLY BEFORE PROCESSES					
• PARENTHEICAL INFO FOR REF ONLY					
HOLE TOLERANCE					
.013 - .004		.126 - .005		.251 - .006	
THRU - .001		THRU - .001		THRU - .001	
.001 - .008		.751 - 1.001		1.001 - 2.001	
THRU - .001		THRU - .010		THRU - .012	
.750 - .001		1.000 - .001		2.000 - .001	
999689	8740	DATE 4/6/78			
NEXT ASSY USED ON		DATE 4/13/78		DATE 4/11/78	
APPLICATION		DATE 4/11/78		DATE 4/11/78	
C 96214			DRAWING NO 999736		
ALL NONE			SHEET		

4

3

34

2

1 LM

FILM

LIST OF MATERIALS

DATE 3-28-79
P/N 0999736

Cable Assembly, Carriage Drive

000 1
REV D

PRINT ITEM NUMBER	QUANTITY PER ASSEMBLY	PART NUMBER	DESCRIPTION
0001	00001.000	0972484-0004	CONNECTOR HOUSING 4 CONTACT
0001A			P105
0002	00002.000	0972104-0001	CONTACT ELEC-LOCKING,WIRE-TO.025 SQ POST
0003	00001.000	0996497-0001	KEYING PLUG CONNECTOR
0007	00002.000	0230252-0020	CABLE,2COND,22AWG,COMMUNICATIONS,BLK/CLR
0008	00000.250	0972146-0006	TUBING,HEAT SHRINKABLE .250 ID BLACK
0009	00002.000	0996334-0002	TERMINAL .187 X .020 MALE
0010	00001.000	0539882-0002	LUG #6 AWG.22-16 RING TONGUE VINYL INSUL
0011	00001.000	0418201-0060	STRAP,MARKER,ADJUSTABLE,PLASTIC
0012	00000.500	0972146-0002	TUBING,1/16 ID BLK HEAT SHRINK PVC

NOTES UNLESS OTHERWISE SPECIFIED

- 1 TWO WIRES CRIMPED TOGETHER AT THIS STATION.
- 2 CABLE CLAMP SCREWS & RETAINER CLIPS & SCREWS INCLUDED WITH ITEM 3
- 3 RETAINER CLIP INSTALLED WITH THREADED HOLE ON SAME SIDE AS SCREW HEAD
- 4 SCREWS MUST BE THREADED COMPLETELY THRU RETAINER CLIPS

WIRE NO.	DESCRIPTION	START STATION	FINISH STATION	SIGNATURE	ITEM NO	REMARKS
1	22 AWG BLK	P1 - 1	P2 - 1	AA → AA	9	
2	↑ WHT	↑ - 2	↑ - 3	BA → BB	↑	
3	RED	- 3	- 2	BB → BA		
4	GRN	- 4	- 8	CA → CF		
5	BRN	- 6	- 20	CC → CD		
6	BLU	- 7	- 7	AB → AB		
7	ORG	- 8	- 4	CF → CA		
8	YEL	- 11	- 12	SCA → SCF		
9	VID	- 12	- 11	SCF → SCA		
10	GRY	- 15	- 17	DB → DD		
11	PNK	- 17	- 15	DD → DB		
12	22 AWG TAN	- 20	P2 - 6	CD → CC	9	
13	26 AWG IPVC WHT	- 4	P1 - 5	CA → CB	10	2ND WIRE ON P1-4
14	↑	P1 - 15	P1 - 24	DB → AUXLIO	↑	2ND WIRE ON P1-5
15	↑	P2 - 4	P2 - 5	CA → CB	↑	2ND WIRE ON P2-4
16	26 AWG IPVC WHT	P1 - 17	P1 - 24	DD → AUXLIO	↑	2ND WIRE ON P1-17

REV	DESCRIPTION	DATE	APPROVED
A	415775(C) REV PER ENGR MARKUP	11/10/76	
FORMAL RELEASE			
B	CN418888	8-5-77	
1) ITEM 10 WAS PN535347-3999			

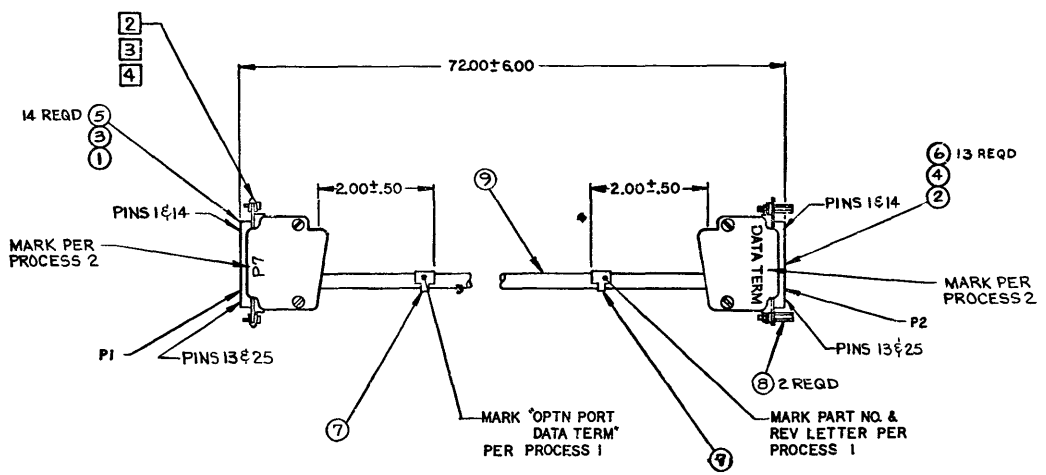

2	MARK	100-07	712	COLOR WHITE, TYPE 9
1	MARK	100-07	712	COLOR BLACK, TYPE 6
SEQ NO	IDENT	F SPEC	NO	ADDITIONAL
	PROCESS			CLASSIFICATION
PROCESSES — FOR CORRELATION TO GOVT AND SPECIFICATIONS — SEE DRAWING 720467				

-1 QTY	ITEM NO	PART OR IDENTIFYING NUMBER	NOVENCATURE OR DESCRIPTION	PROCUREMENT SPECIFICATION	NOTES
			PARTS LIST		
			UNLESS OTHERWISE SPECIFIED • DIMENSIONS ARE IN INCHES • TOLERANCES ARE ANGLES ± 1° 3 PLACE DECIMALS ± 0.01 2 PLACE DECIMALS ± 0.02 • INTERPRET DRAWING PER MIL-D-1000 • REMOVE ALL BURRS AND SHARP EDGES • CONCENTRICITY MACHINED DIAMETERS DID FIM • DIMENSIONAL LIMITS APPLY BEFORE PROCESSES • PARENTHETICAL INFO FOR REF ONLY HOLE TOLERANCE 013 THRU .001 130 THRU .005 251 THRU .006 125 .001 250 .001 500 .001 501 .008 751 .010 1.001 .012 750 .001 1.000 .001 2.000 .001		
	993105	8744	LENOVER 9-1-76 TEXAS INSTRUMENTS INCORPORATED Dallas Texas CABLE ASSEMBLY, DATA TERMINAL SCALE NONE	993210	

LIST OF MATERIALS

DATE 8-3-77
P/N 993210

Cable Assembly, Data Terminal

000 1
REV B

PRINT ITEM NUMBER	QUANTITY PER ASSEMBLY	PART NUMBER	DESCRIPTION
0001	00001.000	0539409-0005	CONNECTOR, PLUG 25 PINS
0002	00001.000	0539409-0006	CONNECTOR, RCPT 25 PINS
0003	00001.000	0539903-0001	HOOD, CONN 25 PIN WITH RETAINERS
0004	00001.000	0539903-0006	HOOD, CONNECTOR
0005	00014.000	0539430-0003	CONTACT, PIN 24-20AWG .068 INSUL DIA
0006	00013.000	0539430-0004	CONTACT, SOCKET 24-20AWG .068 INSUL DIA
0007	00002.000	0418201-0060	STRAP, MARKER, ADJUSTABLE, PLASTIC
0008	00002.000	0406769-0001	SCREW, SPECIAL, CONNECTOR LOCKING
0009	00006.500	0972444-0005	CABLE, 12COND 22AWG UL LISTED
0010	AR	0538347-1999	WIRE HOOK UP B-26 AWG 19 STR WHITE
0011	REF	0983399-9901	TEST PGH, DATA TERMINAL CABLE-OMNI

A

996289



Level 2

4001

6150 0200

APPLICATION		REVISIONS			
USED ON	USED ON	LTR	DESCRIPTION	DATE	APPROVED
8501		A	415859 (E) LENOVER 1-28-77	1/28/77	Henson
8733		B	CN423891 Larry King	6-3-77	Font
8744		C	CN424086 L. Piercey	7-19-77	Font
8738		D	CN433186 F. Espinoza	4-21-78	TKW
7069		E	CN437107 Rick Hayes	11/22/78	Henson
		F	CN436042 GOULET ADDED SH 2.1	12/18/79	PE
		G	CN. 439003 REKHA SETH	4/28/79	D. Talbot
		H	CN 439009 REKHA SETH	6/16/79	Henson

1.0 SCOPE:

THIS SPECIFICATION COVERS THE REQUIREMENTS FOR A 3 PIN POWER CORD, UNDERWRITERS LABORATORIES AND CSA APPROVED.

2.0 APPLICABLE DOCUMENTS:

THE FOLLOWING DOCUMENTS OF ISSUE IN EFFECT ON THE DATE OF INVITATION TO BID OR REQUEST FOR PROPOSAL FORM A PART OF THIS SPECIFICATION TO THE EXTENT SPECIFIED HEREIN. IN THE EVENT OF ANY CONFLICT BETWEEN THIS DOCUMENT AND THE REFERENCE DOCUMENTS, THIS DOCUMENT SHALL GOVERN.

MIL-STD-105 SAMPLING PROCEDURES AND TABLES FOR INSPECTION

BY ATTRIBUTES

UL 62 FLEXIBLE CORD AND FIXTURE WIRE

SPECIFICATION CONTROL DRAWING

REV	F																
SHEET	2.1																
REV STATUS OF SHEETS	REV	H	G	C	H												
	SHEET	1	2	3	4												
UNLESS OTHERWISE SPECIFIED DIMENSIONS ARE IN INCHES TOLERANCES	DWN	[Signature]				DATE	[Date]										
	CHK	[Signature]				DATE	[Date]										
IDENTIFYING NUMBERS SHOWN IN PARENTHESES FOR REFERENCE ONLY	ENGR	[Signature]				DATE	[Date]										
	QA	[Signature]				DATE	[Date]										
INTERPRET DWG. IN ACCORDANCE WITH MIL-STD-100	APVD	[Signature]				DATE	[Date]										
	MFR	[Signature]				DATE	[Date]										
	PCC	[Signature]				DATE	[Date]										
	RELEASE	[Signature]				DATE	[Date]										
	SIZE	A			CODE IDENT NO	96214			DRAWING NO	996289							
	SCALE	NONE										SHEET	1 of 5				

3.0 REQUIREMENTS:

3.1 PHYSICAL: SEE FIGURE 1

3.1.1 PLUG: PVC 80-86A SHORE. DUROMETER HARDNESS .. 60°C SERVICE.

3.1.2 CORD: #18 AWG, 3 CONDUCTOR, TYPE SJT MEETING U/L STANDARD 62 REQUIREMENTS, COLOR (REF) GRAY OR BLACK -0001 ONLY,
GRAY -0002 ONLY

3.1.3 MARKING: PARTS SHALL BE MARKED WITH THE MANUFACTURER'S IDENTIFICATION, WIRE TYPE (SJT), WIRE SIZE (18 AWG), AND NUMBER OF WIRES (3 CONDUCTOR).

3.2 ELECTRICAL: 6 AMPS MINIMUM RATING @ 125 VOLTS

3.3 ENVIRONMENTAL:

3.3.1 STORAGE TEMPERATURE RANGE: -40°C TO 80°C

NOTE: [1] CORD GRIP DESIGNED TO CLIP TO BODY (CABLE) OF CORD ASSY. -0002 ONLY.

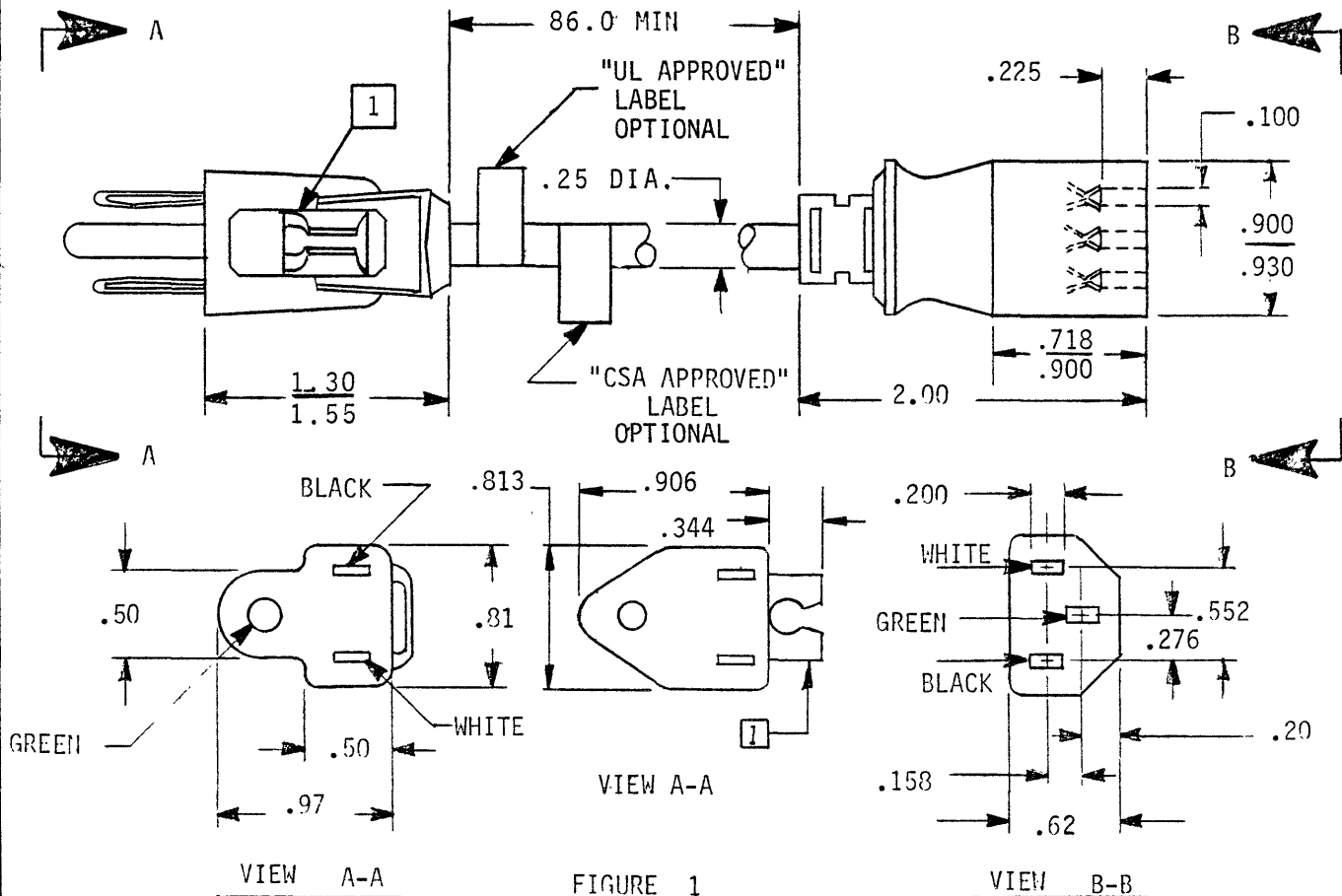

FIGURE 1



TEXAS INSTRUMENTS
INCORPORATED
DIGITAL SYSTEMS DIVISION
HOUSTON, TEXAS

A

996289
SHEET 2

REV
G

3.4 MECHANICAL

3.4.1 RETENTION FORCE, FEMALE PLUG: 3LB MINIMUM, 20LB MAXIMUM AFTER 10 CONDITIONING CYCLES TO A MATING RECEPTACLE.



TEXAS INSTRUMENTS
INCORPORATED
DIGITAL SYSTEMS DIVISION
HOUSTON, TEXAS

A

996289

SHEET 2.1

REV

4.0 QUALITY ASSURANCE PROVISIONS:

4.1 RESPONSIBILITY FOR INSPECTION:

UNLESS OTHERWISE SPECIFIED IN THE CONTRACT OR PURCHASE ORDER, THE SUPPLIER SHALL BE RESPONSIBLE FOR PERFORMING INSPECTIONS THAT ARE SUFFICIENT TO ASSURE THAT THE PARTS SUPPLIED MEET THE REQUIREMENTS SPECIFIED HEREIN.

4.2 LOT ACCEPTANCE:

LOTS FURNISHED TO THIS SPECIFICATION SHALL BE CAPABLE OF PASSING A SAMPLING INSPECTION FOR DEFECTS TO AN ACCEPTANCE QUALITY LEVEL (AQL) OF ONE PERCENT FOR NORMAL SINGLE SAMPLING, LEVEL II, PER MIL-STD-105. FAILING LOTS SHALL BE SUBJECT TO REJECTION.

5.0 PREPARATION FOR DELIVERY:

5.1 PACKAGING:

PACKING AND WRAPPING SHALL BE SUFFICIENT TO PROTECT AGAINST DAMAGE OR LOSS DURING SHIPMENT FROM THE SUPPLIER TO THE DESTINATION SPECIFIED IN THE PURCHASE ORDER. (BULK PACK IS ACCEPTABLE)

5.2 MARKING:

THE PRIMARY WRAPPING OR PACKAGING SHALL BE MARKED WITH THE TI PART NUMBER (SEE PART NUMBER BLOCK) AND THE COUNT CONTAINED. ADDITIONAL MARKINGS ARE PERMITTED.



TEXAS INSTRUMENTS
INCORPORATED
DIGITAL SYSTEMS DIVISION
HOUSTON TEXAS

A

996289
SHEET 3

REV
C

SUGGESTED SOURCE(S) OF SUPPLY:

- 1. PACIFIC ELECTRICORD CO. (80126)
747 WEST REDONDO BEACH BLVD.
GARDENA, CA 9C
- 2. BELDEN CORP (16428)
P. O. BOX 1101
RICHMOND, INDIANA 47374
- 3. MILLER ELECTRIC
DIV. OF COLUMBIA ELECTRONIC CABLES
11 COVE ST.
NEW BEDFORD, MA. 53909
- 4. CORD SPECIALITIES (CORDSP)
10632 GRAND AVE.
FRANKLIN PARK, IL 60131

TI PART NUMBER	MFR PART NUMBER		
	SOURCE 1	SOURCE 2	SOURCE 3
996289-0001	0-8037-008 BK	KH 9213-10	996289-0001
996289-0002	0-8037-008 GY	KH 9213- 8	996289-0002

TI PART NUMBER	MFR PART NUMBER		
	SOURCE 4	SOURCE 5	SOURCE 6
996289-0001	996289-0001		
996289-0002	996289-0002		

	 TEXAS INSTRUMENTS INCORPORATED DIGITAL SYSTEMS DIVISION HOUSTON, TEXAS	A	996289	REV H
			SHEET 4	

993211

NOTES UNLESS OTHERWISE SPECIFIED

- 1 CABLE CLAMP SCREWS & RETAINER CLIPS & SCREWS INCLUDED WITH ITEM 3
- 2 RETAINER CLIP INSTALLED WITH THREADED HOLE ON SAME SIDE AS SCREW HEAD
- 3 SCREWS MUST BE THREADED COMPLETELY THRU RETAINER CLIPS

WIRE NO.	DESCRIPTION	START STATION	FINISH STATION	SIGNATURE	ITEM NO.	REMARKS
1	22 AWG-BLK	P1-1	P2-1	CRKT -1	9	
2	-WHT	-2	-2			
3	-RED	-3	-3			
4	-GRN	-4	-4			
5	-ORN	-5	-5			
6	-BLU	-6	-6			
7	-WHT/BLK	-7	-7			
8	-RED/BLK	-8	-8			
9	-GRN/BLK	-9	-9			
10	-ORN/BLK	-10	-10			
11	-BLU/BLK	-11	-11			
12	-BLK/WHT	-12	-12			
13	-RED/WHT	-13	-13			
14	-GRN/WHT	-14	-14			
15	-BLU/WHT	-15	-15			
16	-BLK/RED	-16	-16			
17	-WHT/RED	-17	-17			
18	-ORN/RED	-18	-18			
19	-BLU/RED	-19	-19			
20	-RED/GRN	-20	-20			
21	-ORN/GRN	-21	-21			
22	-BLK/WHT/RED	-22	-22			
23	-WHT/BLK/RED	-23	-23			
24	-RED/BLK/WHT	-24	-24			
25	22 AWG-GRN Blk Wht	P1-25	P2-25	CRKT -25		

REV	DESCRIPTION	DATE	APPROVED
A	415775(1) V. 20 5/10/70 REV PER ENGR MARK IT	5/10/70	[Signature]

FORMAL RELEASE

6-152

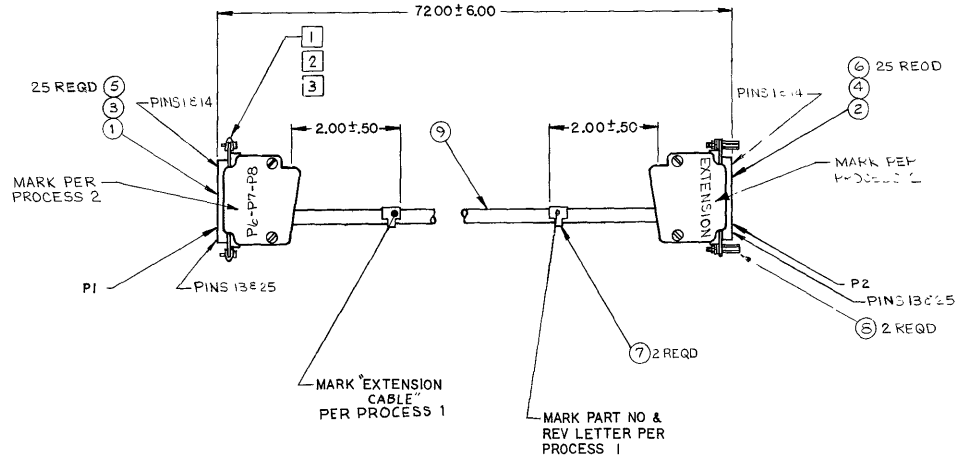

2	MARK	100-07	712	COLOR WHITE, TYPE 9
1	MARK	100-07	712	COLOR BLACK, TYPE 6
SERIAL NO.	IDENT	PROCESS	CLASSIFICATION	ADDITIONAL NOTES

PROCESSES - FOR CORRELATION TO GOVT/IND SPECIFICATIONS SEE YI DRAWING 729467

QTY	ITEM NO.	PART OR IDENTIFYING NUMBER	NOMENCLATURE OR DESCRIPTION	PROCUREMENT SPECIFICATION	NOTES
					UNLESS OTHERWISE SPECIFIED
					• DIMENSIONS ARE IN INCHES
					• TOLERANCES - ANGLES .1°
					• PLACE DECIMALS .02
					• INTERFERE & DRAWING PER MIL D1000
					• REMOVE ALL BURRS AND SHARP EDGES
					• CONCENTRICITY MACHINED DIAMETERS .010 ± .001
					• DIMENSIONAL LIMITS APPLY BEFORE PROCESSES
					• PARENTHETICAL INFO FOR REF ONLY
					HOLE TOLERANCE
					1.00 ± .006
					1.25 ± .007
					1.50 ± .008
					1.75 ± .009
					2.00 ± .010
					2.50 ± .012
					3.00 ± .015
					3.50 ± .018
					4.00 ± .020
					4.50 ± .022
					5.00 ± .025
					5.50 ± .028
					6.00 ± .030
					6.50 ± .032
					7.00 ± .035
					7.50 ± .038
					8.00 ± .040
					8.50 ± .042
					9.00 ± .045
					9.50 ± .048
					10.00 ± .050
					10.50 ± .052
					11.00 ± .055
					11.50 ± .058
					12.00 ± .060
					12.50 ± .062
					13.00 ± .065
					13.50 ± .068
					14.00 ± .070
					14.50 ± .072
					15.00 ± .075
					15.50 ± .078
					16.00 ± .080
					16.50 ± .082
					17.00 ± .085
					17.50 ± .088
					18.00 ± .090
					18.50 ± .092
					19.00 ± .095
					19.50 ± .098
					20.00 ± .100
					20.50 ± .102
					21.00 ± .105
					21.50 ± .108
					22.00 ± .110
					22.50 ± .112
					23.00 ± .115
					23.50 ± .118
					24.00 ± .120
					24.50 ± .122
					25.00 ± .125
					25.50 ± .128
					26.00 ± .130
					26.50 ± .132
					27.00 ± .135
					27.50 ± .138
					28.00 ± .140
					28.50 ± .142
					29.00 ± .145
					29.50 ± .148
					30.00 ± .150
					30.50 ± .152
					31.00 ± .155
					31.50 ± .158
					32.00 ± .160
					32.50 ± .162
					33.00 ± .165
					33.50 ± .168
					34.00 ± .170
					34.50 ± .172
					35.00 ± .175
					35.50 ± .178
					36.00 ± .180
					36.50 ± .182
					37.00 ± .185
					37.50 ± .188
					38.00 ± .190
					38.50 ± .192
					39.00 ± .195
					39.50 ± .198
					40.00 ± .200
					40.50 ± .202
					41.00 ± .205
					41.50 ± .208
					42.00 ± .210
					42.50 ± .212
					43.00 ± .215
					43.50 ± .218
					44.00 ± .220
					44.50 ± .222
					45.00 ± .225
					45.50 ± .228
					46.00 ± .230
					46.50 ± .232
					47.00 ± .235
					47.50 ± .238
					48.00 ± .240
					48.50 ± .242
					49.00 ± .245
					49.50 ± .248
					50.00 ± .250

TEXAS INSTRUMENTS INCORPORATED Dallas Texas

CABLE ASSY, EIA EXTENSION

D96214 993211

SCALE NONE REV A SHEET

8

7

6

5

4

3

2

1

LIST OF MATERIALS

DATE 12-1-76
P/N 993211

Cable Assembly, EIA Extension

000 1
REV A

PRINT ITEM NUMBER	QUANTITY PER ASSEMBLY	PART NUMBER	DESCRIPTION
0001	00001.000	0539409-0005	CONNECTOR, PLUG 25 PINS
0002	00001.000	0539409-0006	CONNECTOR, RCPT 25 PINS
0003	00001.000	0539903-0001	HOOD, CUNN 25 PIN WITH RETAINERS
0004	00001.000	0539903-0006	HOOD, CONNECTOR
0005	00025.000	0539430-0003	CONTACT, PIN 24-20AWG .068 INSUL DIA
0006	00025.000	0539430-0004	CONTACT, SOCKET 24-20AWG .068 INSUL DIA
0007	00002.000	0418201-0060	STRAP, MARKER, ADJUSTABLE, PLASTIC
0008	00002.000	0406769-0001	SCREW, SPECIAL, CONNECTOR LOCKING
0009	00006.500	0972444-0006	CABLE, 25COND 22AWG UL LISTED
0010	REF	0983398-9901	TEST PGM, EIA EXTENSION CABLE-OMNI

999742

NOTES UNLESS OTHERWISE SPECIFIED
 1 INSTALL KEY (ITEM 9) IN POSITION P3-19
 2 INSTALL CONTACT (ITEM 4) IN UNUSED POSITIONS P3-13

3 MARK PER 286570 (ITEM 1) LINE FOR TEXT "EIA"

WIRE NO	DESCRIPTION	SIGNATURE	START	FINISH	REMARKS	LM IT NO
		ETA CCITT				
1	24AWG WHITE	AA 101	P3-12	1J1-1		
2		BA 103	6	2		
3		BB 104	9	3		
4		CA 105	1	4		
5		CB 106	11	5		
6		CC 107	4	6		
7		AB 102	7	7		
8		CF 109	10	8		
9		SCA 118	2	11		
10		SCF 119	3	12		
11		CD 108	8	20		
12		CE 125	5	22		
13	24AWG WHITE	CH 111	P3-24	1J1-23		

REVISIONS			
REV	DESCRIPTION	DATE	APPROVED
A	CN 430884 LM UPDATE	4-23-61	[Signature]
B	CN 440303 J. CLARK 1) LM ITEM 2 DTY WAS 12 ITEM 5 DTY WAS 32.5 AND DASH NR WAS 3999. DESC OF WIRE WAS B-22 AWG ITEM 3 DASH NR WAS 0013. DESC WAS 203 PVC 2) ADDED WIRE NR 13 IN C-5. I.N.E.D. 4 ADDED "EIA (CCITT)", DELETED SIGNATURES UNDER REMARKS COLUMN 3) 2D-B [Signature] WAS "INSTALL CONTACTS P3-13 AND P3-24"	5/19/72	[Signature]
C	CN 439733 J. CLARK 1) 2B-B "NEAR SIDE" WAS FAR SIDE	8/29/71	[Signature]
D	CN 439511 J. CLARK 1) 2D-B UNDER FINISH 1J1-22 WAS 1J1-21	7-2-72	[Signature]
E	CN 445414 [Signature] 1) DELE DIM .75 ± .25 2) DELE DIM 26.00 ± .50 3) DIM 24.75 ± .75 WAS 28.50 ± 1.00 4) 2 B-7 ROTATED CABLE 90°	11-22-73	[Signature]
F	CN 445439 [Signature] 1) EC6 DIM 25.75 ± .75 WAS 24.25 ± .75	11-17-73	[Signature]
G	CN 450993 C. [Signature] 1) ADDED ITEMS 6 AND 11 2) ADDED NOTE B 13) DIM 26.75 ± .75 W/L 25.75 ± .75	3/6/79	[Signature]

6-154

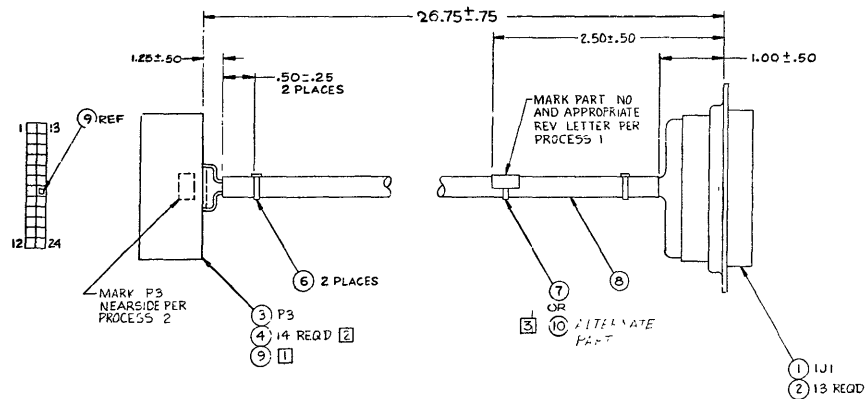

2	MARK	100-07	7/2	COLOR WHITE TYPE 5 CU OR BLACK TYPE 6	
1	MARK	100-07	7/2		
IDENT	F.N.C.	NO	ADDITIONAL		NOTES
PROCESS		CLASSIFICATION			
PHOENIX - FOR CORRELATION TO CONTINENTAL SPECIFICATIONS SEE TYPICAL 7-9-67					

ITEM NO	QTY	PART OR IDENTIFYING NUMBER	NOTE	DATE	BY	APPROVED
			DIMENSIONS ARE UNLESS OTHERWISE SPECIFIED TOLERANCES ARE: .010 UNLESS OTHERWISE SPECIFIED DIMENSIONS ARE UNLESS OTHERWISE SPECIFIED DIMENSIONS ARE UNLESS OTHERWISE SPECIFIED DIMENSIONS ARE UNLESS OTHERWISE SPECIFIED DIMENSIONS ARE UNLESS OTHERWISE SPECIFIED DIMENSIONS ARE UNLESS OTHERWISE SPECIFIED			
			TRAVEL INSTRUMENTS CABLE ASSEMBLY, EIA (INTERNAL) D.96214 999742			

8 7 6 5 4 3 2 1

LIST OF MATERIALS

DATE 8/1/79
P/N 999742

Cable Assembly, EIA (Internal)

0001
REV G

PRINT NUMBER	QUANTITY PER ASSEMBLY	PART NUMBER	DESCRIPTION
0001	00001.000	0539409-0006	CONNECTOR, RCPT 25 PINS
0001A			1J1
0002	00013.000	0539430-0004	CONTACT, SOCKET 24-20AWG .068 INSUL DIA
0003	00001.000	0972202-0025	CONNECTOR, .100 CENTER DUAL MINILATCH
0003A			P3
0004	00014.000	0972482-0006	CONTACT, ELECTRICAL, CRIMP
0005	00035.000	0538347-2999	WIRE HOOKUP B-24 AWG 19 STR WHITE
0006	00002.000	0418212-0040	STRAP, TIEDOWN, ADJUSTABLE, PLASTIC
0007	00001.000	0418201-0060	STRAP, MARKER, ADJUSTABLE, PLASTIC
0008	00002.250	0972436-0012	INSULATION, FLEXIBLE
0009	00001.000	0800335-0001	KEY, POLARIZATION, CONNECTOR
0010	00000.000	2210317-0001	LABEL, BLANK, CABLE MARKER
0010A			ITEM 10 MAY BE USED AS AN
0010B			ALTERNATE FOR ITEM 7
0011	PEF	2265070-9901	SPEC, PRODUC & INSTAL, PRE-PRT CBL MARKERS

APPLICATION		REVISIONS				
USED ON	USED ON	LTR	DESCRIPTION	DATE	APPROVED	
	8501	A	415858 (E) R. Wheeler	11-17-76	"1/18/76	Repin Jr
	8733	B	CN408582 Chin Rev 2-16-77	3-15-77	3/15/77	Honor
	8740	C	CN432077 A. CLARK	7-5-78	7-5-78	Epping
		D	CN434117 Tech 7/2/78	11/10/78	11/10/78	Epping
		E	CH 443075 Gould	1/23/79	1/23/79	PE

1.0 SCOPE:

THIS SPECIFICATION COVERS THE REQUIREMENTS FOR A 3 PIN POWER CORD OF UNDERWRITERS LABORATORIES AND CSA AND I.E.C APPROVED CONSTRUCTION

2.0 APPLICABLE DOCUMENTS:

THE FOLLOWING DOCUMENTS OF ISSUE IN EFFECT ON THE DATE OF INVITATION TO BID OR REQUEST FOR PROPOSAL FORM A PART OF THIS SPECIFICATION TO THE EXTENT SPECIFIED HEREIN. IN THE EVENT OF ANY CONFLICT BETWEEN THIS DOCUMENT AND THE REFERENCE DOCUMENTS, THIS DOCUMENT SHALL GOVERN.

- MIL-STD-105 SAMPLING PROCEDURES AND TABLES FOR INSPECTION BY ATTRIBUTES

SPECIFICATION CONTROL DRAWING

REV																
SHEET																
REV STATUS OF SHEETS	REV	E	E	-	B											
	SHEET	1	2	3	4											

UNLESS OTHERWISE SPECIFIED DIMENSIONS ARE IN INCHES TOLERANCES ANGLES ± 1° 3 PLACE DECIMAL ± 010 2 PLACE DECIMAL ± 02

IDENTIFYING NUMBERS SHOWN IN PARENTHESES FOR REFERENCE ONLY

INTERPRET DWG IN ACCORDANCE WITH MIL-STD-100

DWN: 996290 8/27/76 DATE

CHK - R. J. 9/9/76

ENGR: M. J. 9-026

QA: 9-3716

APVD 9-7-76 9/7/76

MFR: J. B. 9/3/76

PCC: 10/1/76

RELEASE: 2/15/76



TEXAS INSTRUMENTS
INCORPORATED
Equipment Group Dallas, Texas

CORD SET, POWER - WEST EUROPEAN

SIZE	CODE IDENT NO	DRAWING NO
A	96214	996290
SCALE	NONE	SHEET 1 of 4

FILMED

3.0 REQUIREMENTS:

3.1 PHYSICAL: SEE FIGURE 1

3.1.1 PLUG: TWO POLE 3 WIRE TYPE WITH TWO GROUNDING CONTACT SYSTEMS, SHALL MEET VDE AND SEMKO REQUIREMENTS, COLOR (REF) GRAY (J. PHILLIP INDUSTRIES EU-426 BFR)

3.1.2 CORD: 18-3 SVT, CONSTRUCTION PER CEE(13)53, JACKET COLOR (REF) GRAY,

3.1.3 FEMALE CONNECTOR: J PHILLIP INDUSTRIES JP-3BME OR EQUIVALENT, SHALL, MEET VDE AND SEMKO REQUIREMENTS, COLOR (REF) GRAY

3.2 ELECTRICAL: 10/16 A 250 V, CEE-7/VII, DIN 49 441

3.3 ENVIRONMENTAL:

3.3.1 STORAGE TEMPERATURE: -40°C TO 80°C

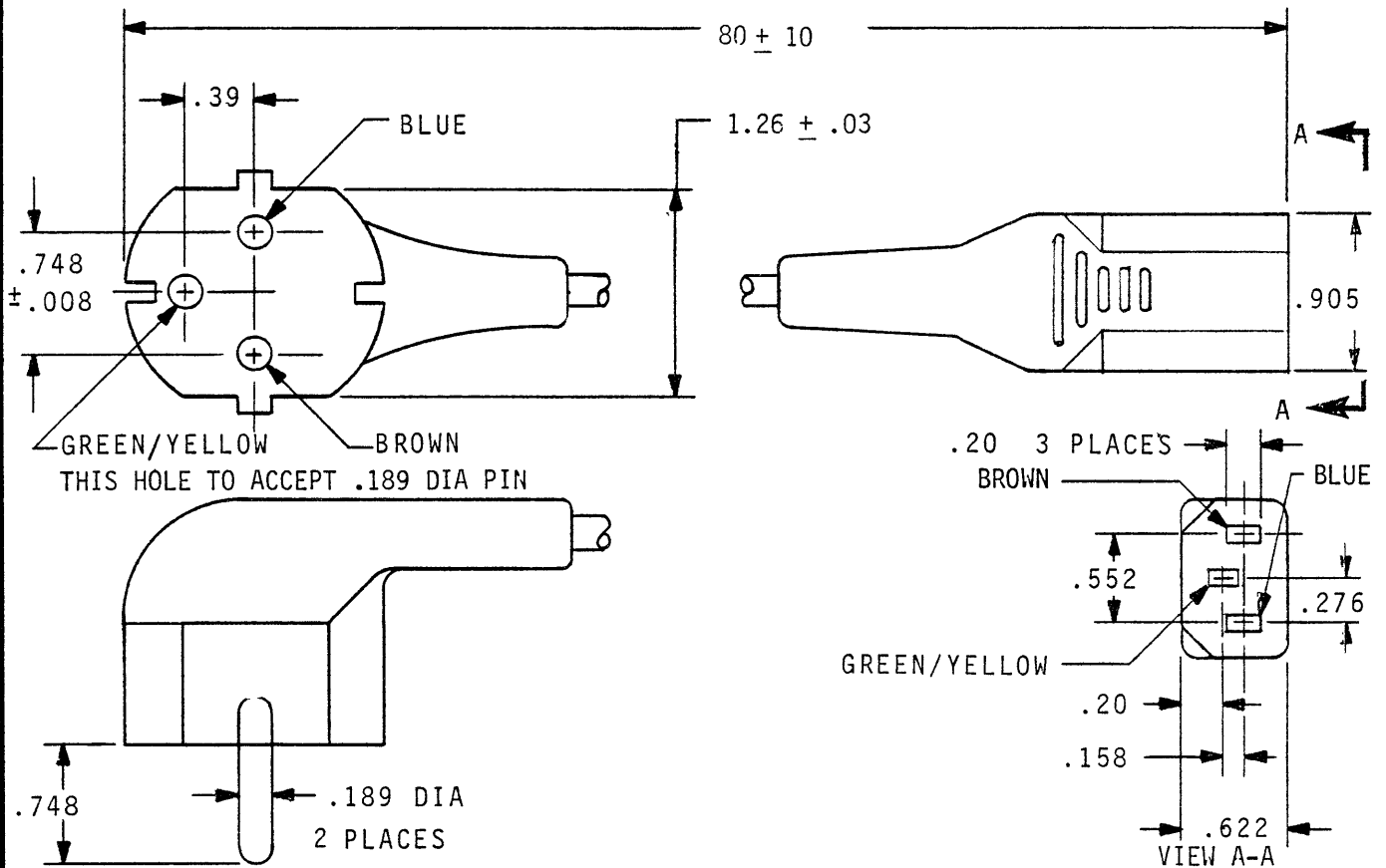

TEXAS INSTRUMENTS
INCORPORATED
DIGITAL SYSTEMS DIVISION
HOUSTON, TEXAS

A

996290
SHEET 2

REV
E

4.0 QUALITY ASSURANCE PROVISIONS:

4.1 RESPONSIBILITY FOR INSPECTION:

UNLESS OTHERWISE SPECIFIED IN THE CONTRACT OR PURCHASE ORDER, THE SUPPLIER SHALL BE RESPONSIBLE FOR PERFORMING INSPECTIONS THAT ARE SUFFICIENT TO ASSURE THAT THE PARTS SUPPLIED MEET THE REQUIREMENTS SPECIFIED HEREIN.

4.2 LOT ACCEPTANCE:

LOTS FURNISHED TO THIS SPECIFICATION SHALL BE CAPABLE OF PASSING A SAMPLING INSPECTION FOR DEFECTS TO AN ACCEPTANCE QUALITY LEVEL (AQL) OF ONE PERCENT FOR NORMAL SINGLE SAMPLING, LEVEL II, PER MIL-STD-105. FAILING LOTS SHALL BE SUBJECT TO REJECTION.

5.0 PREPARATION FOR DELIVERY:

5.1 PACKAGING:

PACKING AND WRAPPING SHALL BE SUFFICIENT TO PROTECT AGAINST DAMAGE OR LOSS DURING SHIPMENT FROM THE SUPPLIER TO THE DESTINATION SPECIFIED IN THE PURCHASE ORDER.

5.2 MARKING:

THE OUTSIDE WRAPPING OR PACKAGING SHALL BE MARKED WITH THE TI PART NUMBER (SEE PART NUMBER BLOCK) AND THE COUNT CONTAINED. ADDITIONAL MARKINGS ARE PERMITTED.



TEXAS INSTRUMENTS
INCORPORATED
DIGITAL SYSTEMS DIVISION
HOUSTON TEXAS

A

996290

SHEET 3

REV

SUGGESTED SOURCE(S) OF SUPPLY:

1. J. PHILLIP INDUSTRIES INC. (JPI)
570Z NORTHWEST HIGHWAY
CHICAGO, IL. 60646

TI PART NUMBER	MFR PART NUMBER	
	SOURCE 1	SOURCE 2
996290-0001	EU426BFR-XP	



TEXAS INSTRUMENTS
INCORPORATED
DIGITAL SYSTEMS DIVISION
HOUSTON, TEXAS

A

996290
SHEET 4

REV
B

6-160

8 7 6 5 4 3

NOTES UNLESS OTHERWISE SPECIFIED

REV	DESCRIPTION	DATE	APPROVED
A	CN430886 J. CLARK 1. UPDATE LM	4/11/78	<i>[Signature]</i>
B	CN4395282, Addendum B-23-78 1. VIEW A-A, ZONE B-4 & VIEW B-B, ZONE C-4 DIMENSION .145 ± .005 WAS .12 ± .06	8-30-78	<i>[Signature]</i>

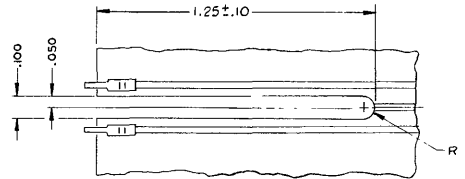
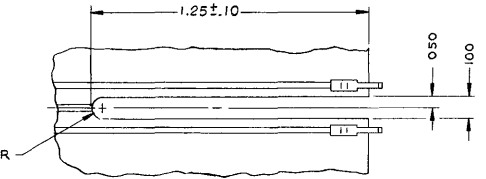
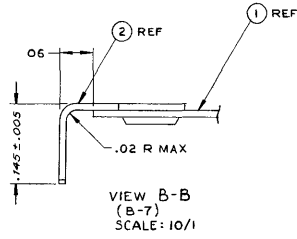
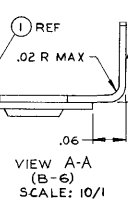
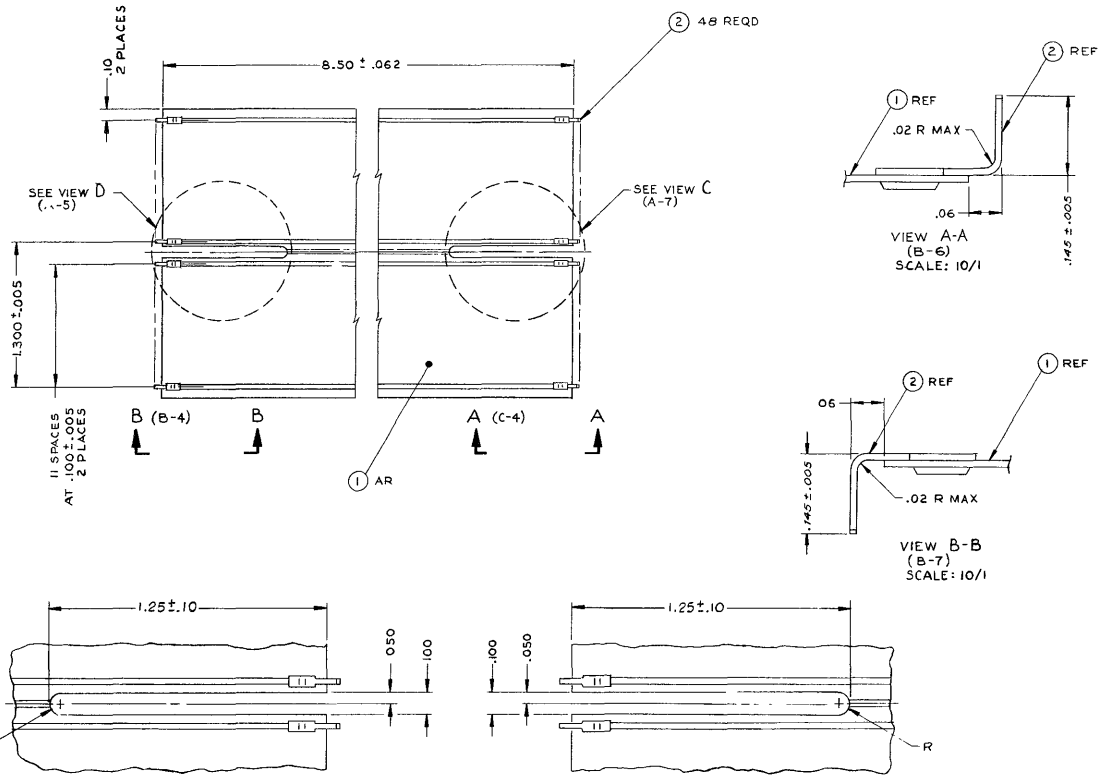

SEQ NO	IDENT	F SPEC	NO	ADDITIONAL CLASSIFICATION	NOTES

ITEM NO	QTY	PART OR IDENTIFYING NUMBER	NOMENCLATURE OR DESCRIPTION	PROCUREMENT SPECIFICATION	NOTES												
999686	8740																
999695	8740																
APPLICATION		<p>UNLESS OTHERWISE SPECIFIED</p> <ul style="list-style-type: none"> DIMENSIONS ARE IN INCHES TOLERANCES: ANGLES ± 1° 3 PLACE DECIMALS ± 0.10 2 PLACE DECIMALS ± 0.2 INTERPRET DRAWING PER MIL D 1000 REMOVE ALL BURRS AND SHARP EDGES CONCENTRICITY MACHINED DIAMETERS .010 FIM DIMENSIONAL LIMITS APPLY BEFORE PROCESSES PARENTHESES INFO FOR REF ONLY <p>HOLE TOLERANCE</p> <table border="1"> <tr> <td>-.013</td> <td>+.004</td> <td>+.026</td> <td>+.005</td> <td>+.231</td> <td>+.006</td> </tr> <tr> <td>.125</td> <td>.001</td> <td>.250</td> <td>.001</td> <td>1.000</td> <td>.001</td> </tr> </table>				-.013	+.004	+.026	+.005	+.231	+.006	.125	.001	.250	.001	1.000	.001
-.013	+.004	+.026	+.005	+.231	+.006												
.125	.001	.250	.001	1.000	.001												

DATE	10/21/77	TEXAS INSTRUMENTS INcorporated Dallas Texas
BY	4/15/78	
CHKD	3/1/78	CABLE ASSEMBLY, KEYBOARD
DATE	3/1/78	
DATE	4/1/78	
DATE	3/2/78	

DATE PREPARED	D 96214	DRAWING NO.	999790
SCALE	2/1	SHEET	1

8 7 6 5 4 3 2 1 LM 1 FILMED

LIST OF MATERIALS

DATE 02-10-78
P/N 0999790

Cable Assembly, Keyboard

000 1
REV B

PRINT ITEM NUMBER	QUANTITY PER ASSEMBLY	PART NUMBER	DESCRIPTION
0001	00000.710	0996742-0003	CABLE,ELEC 26AWG 25CONDCT MULTI FLAT
0002	00048.000	0996748-0004	SOLDER TAB,PLATED 30MIN GOLD OVER NICKEL
0003	00000.000	0996774-0001	CABLE,ELECTRICAL, FLAT, FLEXIBLE
0003A			ITEM 3 MAY BE USED AS AN
0003B			ALTERNATE FOR ITEM 1 & 2

DWG NO 999873 SH

NOTES, UNLESS OTHERWISE SPECIFIED

REVISIONS			
REV	DESCRIPTION	DATE	APPROVED
A	CN439832 A. CLARK I. DIM 7.25 ± .20 WAS 6.25 ± .10	6/20/78	<i>[Signature]</i>

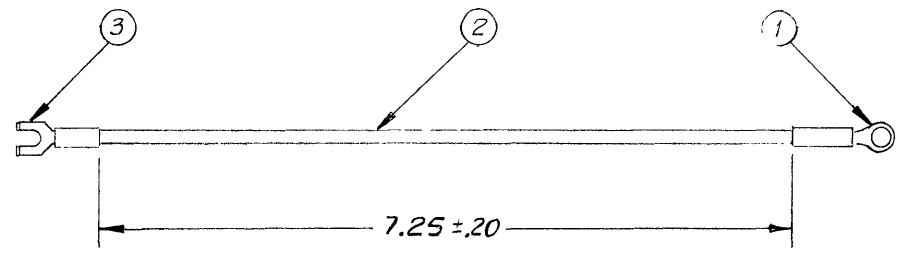

6-162

23

-1 QTY	ITEM NO	PART OR IDENTIFYING NUMBER	NOMENCLATURE OR DESCRIPTION	PROCUREMENT SPECIFICATION	NOTES
PARTS LIST					
		UNLESS OTHERWISE SPECIFIED • DIMENSIONS ARE IN INCHES • TOLERANCES ANGLES ± 1° 3 PLACE DECIMALS ± 010 2 PLACE DECIMALS ± 02 • INTERPRET DRAWING PER MIL-D-1000 • REMOVE ALL BURRS AND SHARP EDGES • CONCENTRICITY MACHINED DIAMETERS .010 FIM • DIMENSIONAL LIMITS APPLY BEFORE PROCESSES • PARENTHETICAL INFO FOR REF ONLY	DWN <i>R. Matsumoto 3-18-78</i> CHK <i>[Signature] 4/13/78</i> ENGR <i>[Signature] 4/14/78</i> APP'D <i>[Signature] 4/14/78</i> CONTR <i>[Signature] 4/14/78</i> RUBED <i>[Signature] 4/14/78</i>	TEXAS INSTRUMENTS INCORPORATED Dallas, Texas	
		HOLE TOLERANCE 013 + 004 THRU + 005 251 + 006 125 - 001 THRU - 001 500 - 001 501 + 008 THRU + 010 1 001 012 750 - 001 THRU - 001 2 000 - 001	SIZE FSCM NO DRAWING NO B 96214 999873		
		999690 8740	SCALE NONE		
		NEXT ASSY USED ON			
		APPLICATION			

34

LM

FILMED

LIST OF MATERIALS

DATE 06-12-78
P/N 0999873

Cable Assembly, Mechanism Ground

000 1
REV A*

PRINT ITEM NUMBER	QUANTITY PER ASSEMBLY	PART NUMBER	DESCRIPTION
0001	00001.000	0232354-0008	LUG, CRIMP, 22-16 AWG #8 RING, STRIP-REEL
0002	00000.550	0996286-5455	WIRE, #18 B-18 19 STRANDS GRN/YEL
0003	00001.000	0232358-0001	LUG, CRIMP, 22-16 AWG, SPADE, STRIP-FORM

999835

NOTES UNLESS OTHERWISE SPECIFIED

1 ANY LETTER (EXCEPT X) MAY BE SUBSTITUTED AT END OPPOSITE TO X

WIRE NO	DESCRIPTION	TOTAL LENGTH	SIGNATURE	START STATION	FINISH STATION	REMARKS
1	WHT/BROWN	-		L201-L	S201-X2	
2	WHT/BLUE	-		L201-N	S201-X1	
3	WHT/BROWN	-		W201-BKN	S201-D2	
4	WHT/BLUE	-		W201-BLU	S201-D1	

REV	DESCRIPTION	DATE	APPROVED
1	CN 445494 Z D-7 5.50 ± .75 WAS 4.50 ± .50 2) CHANGED VIEW A-A 3) ADDED FLAG NOTE 4) ADDED TO REMARKS COLUMN OF WIRE #3 AND #4	11/9/59	[Signature]
2			
3			

D

D

23

C

B

A

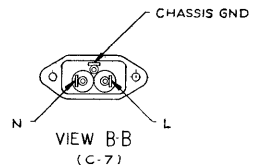
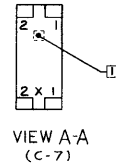
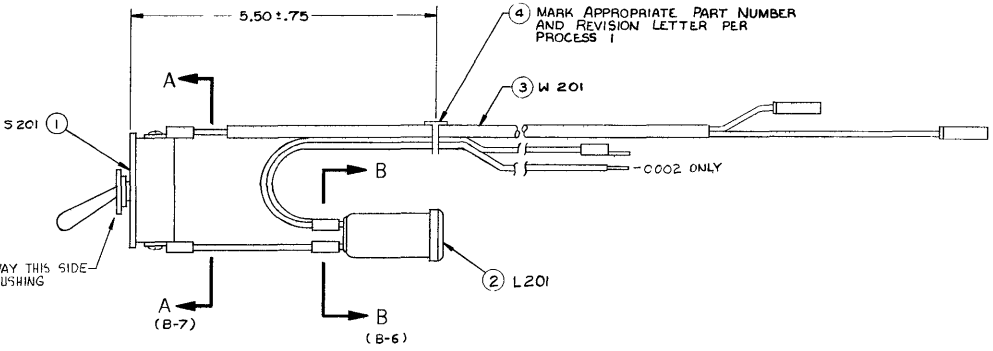

PART NUMBER	DESCRIPTION	REMARKS
999835-0002	CABLE ASSY, POWER DISTRIBUTION (BPO)	BRITISH POST OFFICE
999835-0001	CABLE ASSY, POWER DISTRIBUTION	DOMESTIC

6-164

1	MARK	100-C7	712	COLOR BLK, TYPE 6
SEQ NO	IDENT	F SPEC	NG	ADDITIONAL
PROCESS		CLASSIFICATION		
PROCESSES - FOR CORRELATION TO GOVT/IND SPECIFICATIONS SEE TD DRAWING 729467				

QTY	ITEM NO	PART OR IDENTIFYING NUMBER	NOMENCLATURE OR DESCRIPTION	PROCUREMENT SPECIFICATION	NOTES
PARTS LIST					
UNLESS OTHERWISE SPECIFIED DIMENSIONS ARE IN INCHES TOLERANCES - ANGLES .1° 3 PLACE DECIMALS ± .010 2 PLACE DECIMALS ± .02 INTERPRET DRAWING PER MIL D-1000 REMOVE ALL BURRS AND SHARP EDGES CONCENTRICITY MACHINED DIAMETERS .010 FIM DIMENSIONAL LIMITS APPLY BEFORE PROCESSES PARENTHESES INFO FOR REF ONLY					
999690		B740	HOLE TOLERANCE .013 THRU .008 .125 - .001 .750 - .001 1.000 - .001 1.500 - .001	.251 - .006 .500 - .001 .750 - .001 1.000 - .012 2.000 - .001	DATE PREPARED: 12/11/59 DRAWN BY: [Signature] CHECKED BY: [Signature] DATE: 1/11/60 SCALE: 1/1
NEXT ASSY		USED ON	TEXAS INSTRUMENTS INCORPORATED Dallas, Texas CABLE ASSEMBLY, POWER DISTRIBUTION. DRAWING NO: 999835 SHEET 1		

8

7

6

5

4

3

2

1

FEED

LIST OF MATERIALS

DATE 05-17-79
P/N 0999835

Cable Assembly, Power Distribution

000 2
REV C

PRINT ITEM NUMBER	QUANTITY PER ASSEMBLY	PART NUMBER	DESCRIPTION
0001	00001.000	0996656-0001	TOGGLE SWITCH
0001A			S201
0002	00001.000	2206556-0001	FILTER ASSY. EMI-BPO
0002A			L201
0003	00001.000	0999876-0001	CABLE ASSY, PRIMARY POWER
0003A			W201
0004	00001.000	0418201-0060	STRAP, MARKER, ADJUSTABLE, PLASTIC

DATE 05-17-79
P/N 0999835

000 1
REV C

0001	00001.000	0996656-0001	TOGGLE SWITCH
0001A			S201
0002	00001.000	0999875-0001	FILTER ASSY, EMI
0002A			L201
0003	00001.000	0999876-0001	CABLE ASSY, PRIMARY POWER
0003A			W201
0004	00001.000	0418201-0060	STRAP, MARKER, ADJUSTABLE, PLASTIC

FORM NO 999791

NOTES UNLESS OTHERWISE SPECIFIED

WIRE NO	DESCRIPTION	SIGNATURE	START	FINISH	REMARKS	LM ITEM NO
1	CABLE, FLAT	GND	J20-1	PI03-1		3
2		SOL 6	2	2		3
3		4	3	3		3
4		2	4	4		3
5		5	5	5		3
6		1	6	6		3
7		7	7	7		3
8		SOL 3	8	8		3
9	CABLE, FLAT	COMMON	J20-9	PI03-9		3

REV	DESCRIPTION	REVISIONS	DATE	APPROVED
A	CN 439799 LM UPDATE	<i>A. P. H. H. H.</i>		

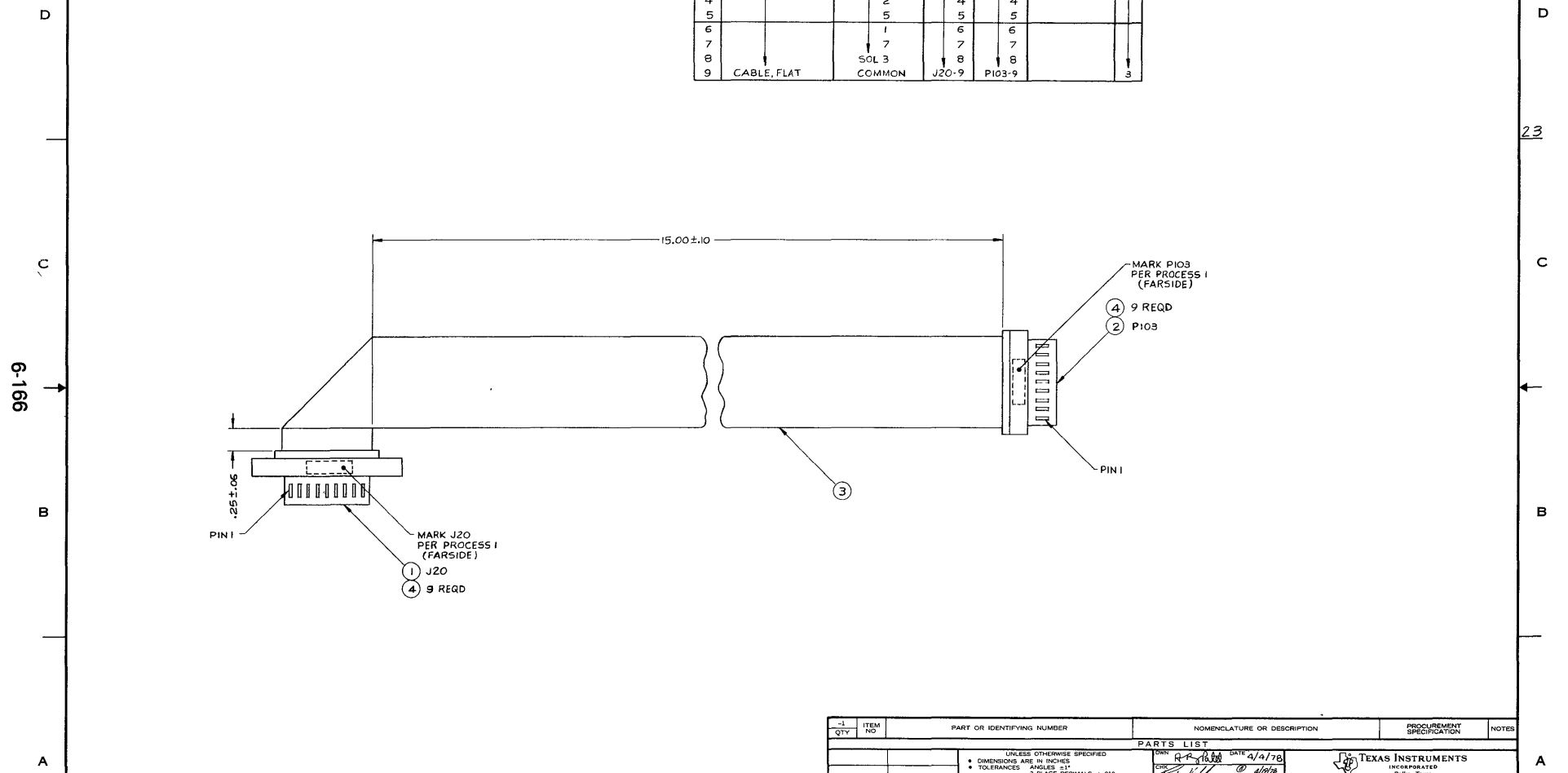

6-166

1	MARK	100-07	712	COLOR WHITE TYPE 9
IDENT	F SPEC	NO	ADDITIONAL	NOTES
PROCESS CLASSIFICATION				

QTY	ITEM NO	PART OR IDENTIFYING NUMBER	NOMENCLATURE OR DESCRIPTION	PROCUREMENT SPECIFICATION	NOTES
PARTS LIST					
UNLESS OTHERWISE SPECIFIED • DIMENSIONS ARE IN INCHES • TOLERANCES ANGLES - 3 3 PLACE DECIMALS = 010 2 PLACE DECIMALS = 52 • INTERPRET DRAWINGS PER MIL D 1000 • REMOVE ALL BURRS AND SHARP EDGES • CONCENTRICITY MACHINED DIAMETERS .010 F/M • DIMENSIONAL LIMITS APPLY BEFORE PROCESSES • PARENTHETICAL INFO FOR REF ONLY					
HOLE TOLERANCE 013 + .004 126 + .005 251 + .006 THRU - .001 THRU - .001 THRU - .001 125 + .001 250 + .001 500 + .001 501 + .008 751 + .010 1,001 + .012 THRU - .001 THRU - .001 THRU - .001 750 + .001 1,000 + .001 2,000 + .001					
999699	8740				
NEXT ASSY USED ON APPLICATION					
DATE 2/12/78 DRAWN <i>[Signature]</i> CHECKED <i>[Signature]</i> APPROVED <i>[Signature]</i> FOR <i>[Signature]</i>			TEXAS INSTRUMENTS INCORPORATED Dallas, Texas CABLE ASSEMBLY, PRINTHEAD DRAWING NO 999791 SCALE 2/1		

PROCESSED - FOR CORRELATION TO GOVT/IND SPECIFICATIONS SEE TI DRAWING 729487

LIST OF MATERIALS

DATE 04-18-79
P/N 0999791

Cable Assembly, Printhead

000 1
REV A

PRINT ITEM NUMBER	QUANTITY PER ASSEMBLY	PART NUMBER	DESCRIPTION
0001	00001.000	0996877-0001	HOUSING, CONN RCPT, SINGLE ROW, W/MTG EARS
0001A			J20
0002	00001.000	0996747-0001	HOUSING, CONN, 9 POS, CABLE OR POUND WIRE
0002A			P103
0003	00001.400	0996249-0001	CABLE, ELECTRICAL 9 CONDUCTOR, FLAT
0004	00018.000	0996876-0001	CONTACT, RECEPTACLE

4

3

2

1

NOTES, UNLESS OTHERWISE SPECIFIED

1 INSTALL KEY (ITEM 3) IN POSITION P6-5

2. POSITION P6-1 IS NOT USED

3 PIN 1 IDENTIFIER IS VENDOR NAME MOLDED IN PART

WIRE NO	DESCRIPTION	TOTAL LENGTH	SIGNATURE	COMPONENT CONNECTION FOR START STATION	COMPONENT CONNECTION FOR FINISH STATION	REMARKS	LM ITEM NO
1	BLU/WHT AR	RIB REV SW	P6-2	TERM 1			11
2	VIO/WHT AR	SWRTN	P6-3	TERM 2			12
3	YEL/WHT AR	PAPOUTSW	P6-4	TERM 3			13
4	ORG/WHT AR	SW RTN	P6-5	TERM 4			14

REVISIONS			
REV	DESCRIPTION	DATE	APPROVED
A	CN 425867 <i>A.B. Bales</i>	4/11/78	<i>[Signature]</i>
	LM UPDATE		
B	CN 439798 <i>[Signature]</i>	4/11/78	<i>[Signature]</i>
	LM UPDATES		
C	CN 439607 <i>[Signature]</i>	4/28/78	<i>[Signature]</i>
	ITEM 9 PN WAS 972436-12		
D	CN 439819 <i>C. Davis</i>	3-24-79	<i>[Signature]</i>
	ITEM 9 PN WAS 972436-11		
E	CN 443616 <i>C. Davis</i>	4-28-79	<i>[Signature]</i>
	ITEM 3 PN WAS 972599-1		
F	CN 439162 <i>M. Haggard</i>	5/12/79	<i>[Signature]</i>
	ITEM 1A DESCRIPTION WAS P306		

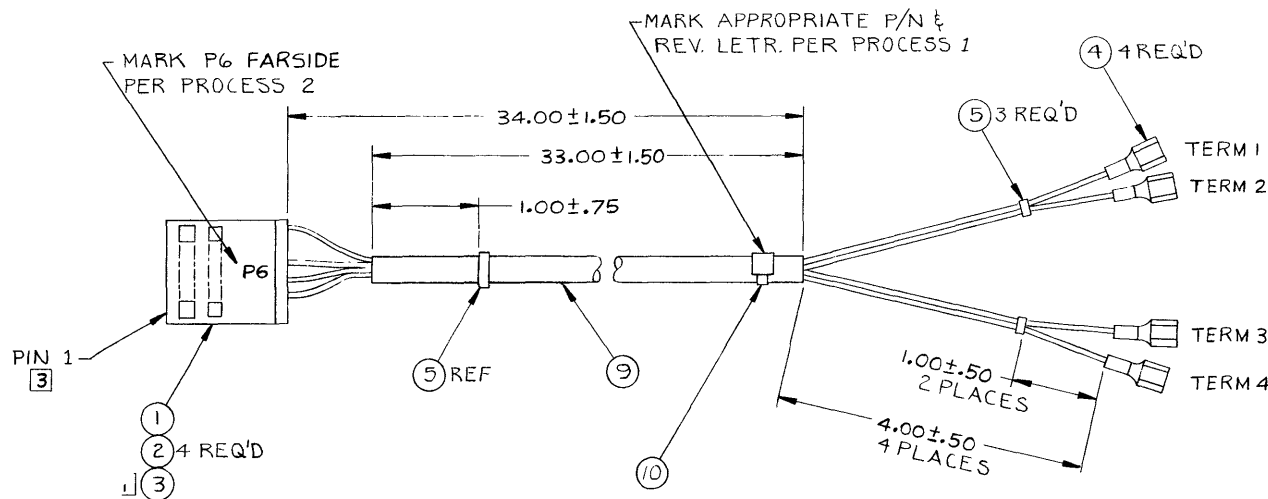

6-168

B

A

999735

2	MARK	100-11	712	COLOR WHITE, TYPE 9
1	MARK	100-J7	712	COLOR BLACK, TYPE 6

SEQ NO	IDENT	F-SPEC	NO	ADDITIONAL	NOTES
	PROCESS			CLASSIFICATION	

PROCESSES — FOR CORRELATION TO GOVT/IND SPECIFICATIONS, SEE TI DRAWING 729467

-1 QTY	ITEM NO	PART OR IDENTIFYING NUMBER	NOMENCLATURE OR DESCRIPTION	PROCUREMENT SPECIFICATION	NOTES
PARTS LIST					
UNLESS OTHERWISE SPECIFIED			DATE		
• DIMENSIONS ARE IN INCHES			DWN 3 February 1978		
• TOLERANCES ANGLES ±1°			CHKD [Signature] 4/11/78		
3 PLACE DECIMALS = .010			DWN [Signature] 4/24/78		
2 PLACE DECIMALS = .02			CHKD [Signature] 4/24/78		
• INTERPRET DRAWING PER MIL-D-1000			DWN [Signature] 4/24/78		
• REMOVE ALL BURRS AND SHARP EDGES			CHKD [Signature] 4/24/78		
• CONCENTRICITY MACHINED DIAMETERS .010 FIM			DWN [Signature] 4/24/78		
• DIMENSIONAL LIMITS APPLY BEFORE PROCESSES			CHKD [Signature] 4/24/78		
• PARENTHEICAL INFO FOR REF ONLY			DWN [Signature] 4/24/78		
HOLE TOLERANCE			CONTR [Signature] 4/24/78		
013 THRU 004	120 THRU 000	251 THRU 008	SIZE FSCM NO		
345 - 001	250 - 001	500 - 001	DRAWING NO		
501 - 008	751 - 010	1001 - 012	C 96214		
752 - 001	1006 - 001	2002 - 001	999735		
NEXT ASSY USED ON			SCALE NONE		
APPLICATION			SHEET		

4

3

34

2

1 LM

11-9925H

LIST OF MATERIALS

DATE 05-04-79
P/N 0999735

Cable Assembly, Ribbon Reverse/Paper Out

000 1
REV E

PRINT ITEM NUMBER	QUANTITY PER ASSEMBLY	PART NUMBER	DESCRIPTION
0001	00001.000	0972484-0006	CONNECTOR HOUSING 6 CONTACT
0001A			P6
0002	00004.000	0972104-0001	CONTACT ELEC-LOCKING,WIRE-TO.025 SQ POST AMP
0003	00001.000	0996497-0001	KEYING PLUG CONNECTOR
0004	00004.000	0972171-0055	TERMINAL,PUSH-ON
0005	00003.000	0418212-0040	STRAP,TIEDOWN,ADJUSTABLE,PLASTIC
0009	00003.000	0972436-0035	INSUL SLVG,#6 PVC .166 ID .020THK
0010	00001.000	0418201-0060	STRAP,MARKER,ADJUSTABLE,PLASTIC
0011	00003.400	0538347-3699	WIRE HOOKUP 8-22 AWG 19 STR BL/WH
0012	00003.400	0538347-3799	WIRE HOOKUP 8-22 AWG 19 STR VI/WH
0013	00003.400	0538347-3499	WIRE HOOKUP 8-22 AWG 19 STR YL/WH
0014	00003.400	0538347-3399	WIRE HOOKUP 8-22 AWG 19 STR OR/WH

NOTES UNLESS OTHERWISE SPECIFIED

1 CABLE CLAMP SCREWS & RETAINER CLIPS & SCREWS INCLUDED WITH ITEM 2

2 RETAINER CLIP INSTALLED WITH THREADED HOLE ON SAME SIDE AS SCREW HEAD

3 SCREWS MUST BE THREADED COMPLETELY THRU RETAINER CLIPS

WIRE COLOR	WIRE NO	DESCRIPTION	START STATION	FINISH STATION	SIGNATURE	ITEM NO	REMARKS
BLK	1	22 AWG CABLE	P1 - 1	P2 - 1	AA	5	PROTECTIVE GROUND
WHT	2		2	2	BA		
RED	3		3	3	BB		
GRN	4		4	4	CA		
GRN	5		5	5	CB		
BLU	6	22 AWG CABLE	6	6	CC	5	DATA SET READY
WHT/BLK	7		7	7	AB		
RED/BLK	8		8	8	CF		
GRN/BLK	9		9	9	SCA		
GRN/BLK	10		10	10	SCF		
BLU/BLK	11	22 AWG CABLE	20	20	CD	5	DATA TERMINAL READY
BLK/WHT	12		22	22	CE		
RED/WHT	13		23	23	CH		
GRN/WHT	14		15	15	OB		
BLU/WHT	15		P1 - 17	P2 - 17	DD		

REV	DESCRIPTION	DATE	APPROVED

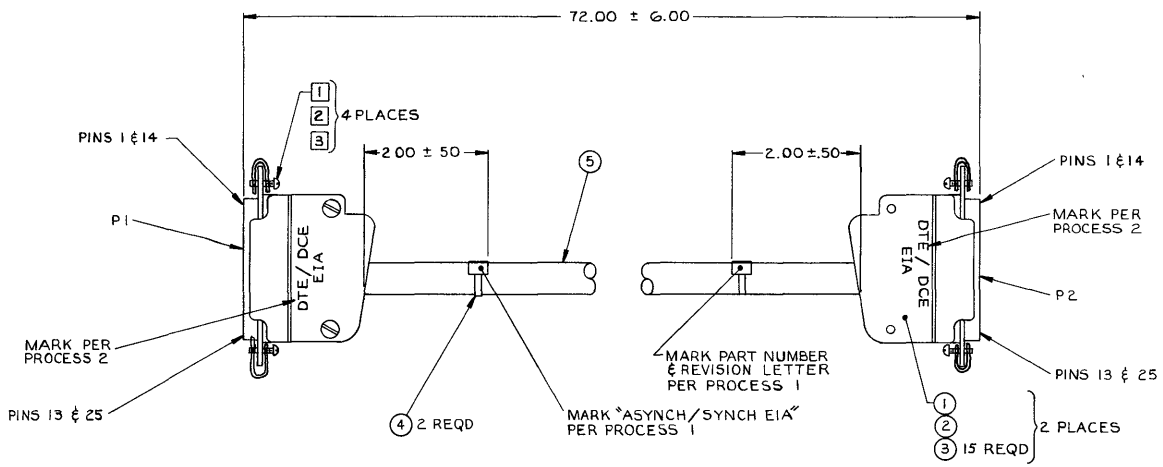

2	MARK	100-07	712	COLOR WHITE, TYPE 9	
1	MARK	100-07	712	COLOR BLACK, TYPE 6	
SEQ NO	IDENT	F SPEC	NO	ADDITIONAL	NOTES

QTY	ITEM NO	PART OR IDENTIFYING NUMBER	NOMENCLATURE OR DESCRIPTION	PROCUREMENT SPECIFICATION	NOTES

UNLESS OTHERWISE SPECIFIED	
• DIMENSIONS ARE IN INCHES	• ANGLES 1°
• TOLERANCES ARE:	• 3 PLACE DECIMALS ± 0.10
• 2 PLACE DECIMALS ± 0.02	• 1 PLACE DECIMALS ± 0.05
• INTERPRET DRAWING PER MIL-STD-1000	• REMOVE ALL BURRS AND SHARP EDGES
• CONCENTRICITY MACHINED DIAMETERS 0.10 FIM	• DIMENSIONAL LIMITS APPLY BEFORE PROCESSES
• PARENTHELTICAL INFO FOR REF ONLY	

999683	8740
NEXT ASSY	USED ON
APPLICATION	

013 THRU 004	150 THRU 005	251 THRU 006
125 001	250 001	500 001
501 008	751 010	1001 THRU 012
750 001	1000 001	2000 001

DATE PREP'D	8-16-79	DATE CHECK'D	8-21-79
DATE DESIGNED	8-22-79	DATE APPROVED	8-25-79
SCALE	NONE	SHEET	1

TEXAS INSTRUMENTS
INCORPORATED
DALLAS, TEXAS

CABLE ASSEMBLY,
ASYNCH/SYNCH EIA

D96214 2207634

LIST OF MATERIALS

DATE 08-06-79
P/N 2207634

Cable Assembly, Synch/Asynch EIA Data Set

000 1
REV *

PRINT ITEM NUMBER	QUANTITY PER ASSEMBLY	PART NUMBER	DESCRIPTION
0001	00002.000	0539409-0005	CONNECTOR, PLUG 25 PINS
0002	00002.000	0539903-0001	HOOD, CONN 25 PIN WITH RETAINERS
0003	00030.000	0539430-0003	CONTACT, PIN 24-20AWG .068 INSUL DIA
0004	00002.000	0418201-0060	STRAP, MARKER, ADJUSTABLE, PLASTIC
0005	00006.500	0972444-0002	CABLE, 15COND 22AWG UL LISTED
0006	REF	2207635-0001	TEST PGM, ASYNCH/SYNCH EIA CABLE OMNI

NOTES, UNLESS OTHERWISE SPECIFIED:
 1 CABLE CLAMP SCREWS AND RETAINER CLIPS INCLUDED WITH ITEM 1
 2 RETAINER CLIP INSTALLED WITH THREADED HOLE ON SAME SIDE AS SCREW HEAD
 3 SCREWS MUST BE THREADED COMPLETELY THRU RETAINER CLIP

WIRE NO.	DESCRIPTION	TOTAL LENGTH	SIGNATURE	START STA.	FINISH STA.	REMARKS	ITEM NO.
1	22AWG BRN/WHT	77	TTYXMTD/R	PI9-2	E1		4
2	22AWG ORN/WHT	77	TTYXMTD	PI8-1	E2		5
3	22AWG YEL/WHT	77	TTYRCVD	PI9-5	E3		6
4	22AWG RED/WHT	77	TTYRCVD/R	PI9-4	E4		7

REVISIONS				
ZONE	LTR	DESCRIPTION	DATE	APPROVED
A		423233 (D) R. Cuth 1-21-77	1/21/77	R. Cuth
FORMAL RELEASE				
B		CN423673 Lanny King	5-2-77	Lanny King
1) ITEM 9 WAS LOCATED 2.00 ± .50 FROM BASE OF PI9 (2) ADDED TRUE LENGTH REF TO ITEM 10				
C		CN426133 J. P. Perry (1) DELE 73.5	7-25-77	J. P. Perry
TRUE LGTH DIM FROM ITEM 10 CALLOUT ON F/D (2) REDREW PI9 & RELOCATED PIN 1 CALLOUT TO BOTTOM OF PI9				
D		CN434167 (E) R. Cuth (1) ITEMS 8 + 10 WERE 232361-2 + 411634-7600 RESP		R. Cuth
E		CN439015 (D) J. B. Perry	6/20/79	J. B. Perry
(1) ITEM 9 QTY WAS 1.0 (2) ADDED DIMS FOR ITEM 9				

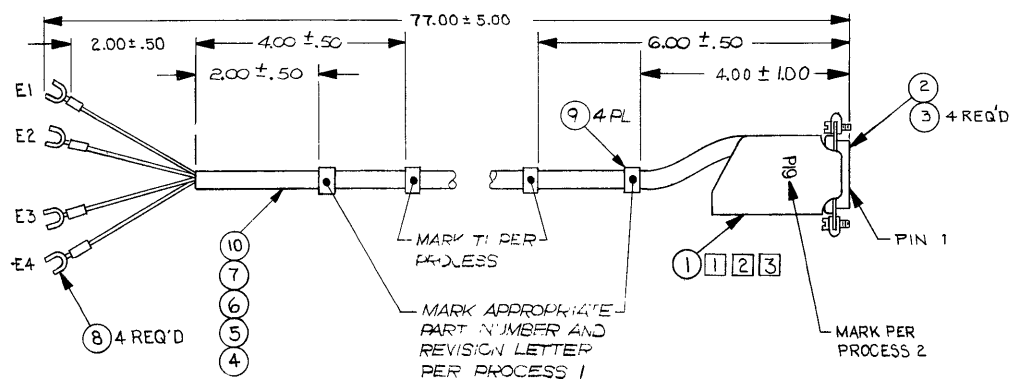

2	MARK	100-07	712	CLR WHITE TYPE 9
1	MARK	100-07	712	CLR BLACK TYPE 6
SEQ NO	IDENT	F-SPEC	NO	ADDITIONAL
PROCESS		CLASSIFICATION		
FOR CORRELATION TO GOVT/IND SPECIFICATIONS, SEE TI DRAWING 729467				

QTY REQD	ITEM NO	CODE IDENT	PART OR IDENTIFYING NUMBER	NOMENCLATURE OR DESCRIPTION	PROCUREMENT SPECIFICATION

UNLESS OTHERWISE SPECIFIED: • REMOVE ALL BURRS AND SHARP EDGES • CONCENTRICITY MACHINED DIAMETERS .010 FIR • DIMENSIONAL LIMITS APPLY BEFORE FINISH PROCESSING • IDENTIFYING NUMBERS SHOWN IN PARENTHESES FOR REFERENCE ONLY • INTERPRET DRAWING IN ACCORDANCE WITH MIL STD 100	UNLESS OTHERWISE SPECIFIED: • DIMENSIONS ARE IN INCHES • TOLERANCES ANGLES ± 1° 3 PLACE DECIMALS ± 010 2 PLACE DECIMALS ± 02	DWN DATE CHK 1-14-77 ENGR 1/21/77 ENGR 1/21/77 QA 1/21/77 APVD 1/21/77 COMTR. NO. DESIGN ACTIVITY RELEASE 2/1/77	TEXAS INSTRUMENTS INCORPORATED Equipment Group Dallas Texas	
	HOLE TOLERANCE 013 THRU ± .004 125 THRU ± .001 501 THRU ± .008 750 THRU ± .001	126 THRU ± .005 250 THRU ± .001 751 THRU ± .010 1000 THRU ± .001	251 THRU ± .006 500 THRU ± .001 1001 THRU ± .012 2000 THRU ± .001	CABLE ASSEMBLY, TTY OPTION
	994402 8733 NEXT ASSY USED ON APPLICATION	SIZE CODE IDENT NO DRAWING NO C 96214 994403	SCALE NONE	SHEET
	34		LM	FILM

6-172

994403

LIST OF MATERIALS

DATE 6-14-79
P/N 994403

Cable Assembly, Current Loop (Ext)

000 1
REV E

PRINT ITEM NUMBER	QUANTITY PER ASSEMBLY	PART NUMBER	DESCRIPTION
0001	00001.000	2210305-0001	HOOD, STRAIN RELIEF, 45/180 DEG., 9 POS
0002	00001.000	0539409-0001	CONNECTOR, RACK & PANEL, PLUG, 9POS
0003	00004.000	0539430-0003	CONTACT, PIN 24-20AWG .068 INSUL DIA
0004	00006.500	0538347-3199	WIRE HOOKUP 8-22 AWG 19 STR BN/WH
0005	00006.500	0538347-3399	WIRE HOOKUP 8-22 AWG 19 STR OR/WH
0006	00006.500	0538347-3499	WIRE HOOKUP 8-22 AWG 19 STR YL/WH
0007	00006.500	0538347-3299	WIRE HOOKUP 8-22 AWG 19 STR RD/WH
0008	00004.000	0232358-0001	LUG, CRIMP, 22-16 AWG, SPADE, STRIP-FORM
0009	00004.000	0418201-0060	STRAP, MARKER, ADJUSTABLE, PLASTIC
0010	00006.500	0972436-0013	INSUL SLVG, .263DIA X .020 WALL THK PVC
0011	REF	0983407-9901	TEST PROG, MC810 TTY OPTION CABLE-OMN1

NOTES UNLESS OTHERWISE SPECIFIED
 1 INSTALL KEY, ITEM 4, IN P13 PIN 8

WIRE NO.	DESCRIPTION	START STATION	FINISH STATION	SIGNATURE	ITEM NO.	REMARKS
1	CABLE, FLAT	P13-1	P30-9	SIG GND	3	
2	CABLE, FLAT	P13-2	P30-8	SIG GND	3	
3	CABLE, FLAT	P13-3	P30-7	+12	3	
4	CABLE, FLAT	P13-4	P30-6	+12	3	
5	CABLE, FLAT	P13-5	P30-5	N.C.	3	
6	CABLE, FLAT	P13-6	P30-4	N.C.	3	
7	CABLE, FLAT	P13-7	P30-3	N.C.	3	
8	CABLE, FLAT	P13-8	P30-2	N.C.	3	
9	CABLE, FLAT	P13-9	P30-1	CHASSIS GND	3	
10	CABLE, FLAT	P13-10	P30-18	SIG GND	3	
11	CABLE, FLAT	P13-11	P30-17	SIG GND	3	
12	CABLE, FLAT	P13-12	P30-16	+5	3	
13	CABLE, FLAT	P13-13	P30-15	+5	3	
14	CABLE, FLAT	P13-14	P30-14	N.C.	3	
15	CABLE, FLAT	P13-15	P30-13	N.C.	3	
16	CABLE, FLAT	P13-16	P30-12	N.C.	3	
17	CABLE, FLAT	P13-17	P30-11	N.C.	3	
18	CABLE, FLAT	P13-18	P30-10	CHASSIS GND	3	

REV	DESCRIPTION	DATE	APPROVED
A	CN 443405	8/23/79	D. Stroma

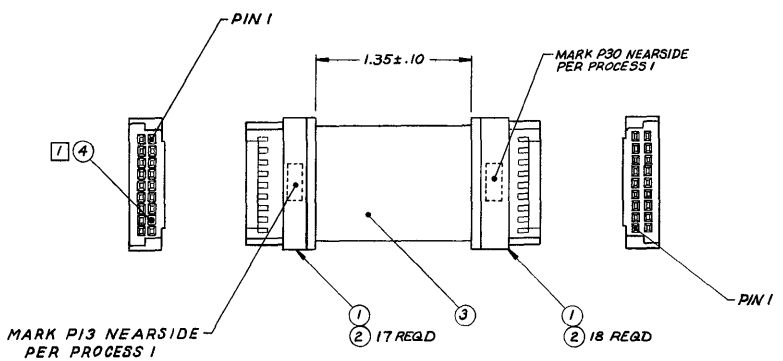

6-174

1	MARK	100-07	712	COLOR WHITE TYPE 9
SEQ NO	IDENT	F.SPEC	NO	ADDITIONAL
	PROCESS			CLASSIFICATION
PROCESSES - FOR CORRELATION TO GOVT/IND SPECIFICATIONS SEE TI DRAWING 729467				

ITEM QTY	ITEM NO	PART OR IDENTIFYING NUMBER	NOMENCLATURE OR DESCRIPTION	PROCUREMENT SPECIFICATION	NOTES
PARTS LIST					
UNLESS OTHERWISE SPECIFIED					
• DIMENSIONS ARE IN INCHES					
• TOLERANCES ARE ANGLES ±11					
• 3 PLACE DECIMALS ±010					
• 2 PLACE DECIMALS ±02					
• INTERPRET DRAWING PER MIL-D-1000					
• REMOVE ALL BURRS AND SHARP EDGES					
• CONCENTRICITY MATCHED DIAMETERS, 010 FIM					
• DIMENSIONAL LIMITS APPLY BEFORE PROCESSES					
• PARENTHETICAL INFO FOR REF ONLY					
HOLE TOLERANCE					
TABLE - 004 126 ± .005 251 ± .006					
129 ± .003 1250 ± .003 1500 ± .003					
551 ± .008 791 ± .010 1001 ± .012					
750 ± .003 1000 ± .003 2000 ± .003					
999734	8740				
NEXT ASSY		USED ON			
APPLICATION					
DWN: <i>D. Stroma</i> DATE: 6-27-79 CHK: <i>Dave Stroma</i> 8-23-79 APP: <i>John Russell</i> 8-23-79 DES: <i>John Russell</i> 8/23/79 DWG: <i>John Russell</i> 8/23/79 REV: <i>John Russell</i> 8/23/79 APP: <i>John Russell</i> 8/23/79 DES: <i>John Russell</i> 8/23/79			TEXAS INSTRUMENTS INCORPORATED DALLAS, TEXAS CABLE ASSEMBLY, OPTION POWER		
96214			DRAWING NO 2206536		
SCALE 2/1			SHEET		

LIST OF MATERIALS

DATE 08-22-79
P/N 2206536

Cable Assembly, Option Power

000 1
REV A

PRINT ITEM NUMBER	QUANTITY PER ASSEMBLY	PART NUMBER	DESCRIPTION
0001	00002.000	0996238-0001	CONNECTOR, HOUSING, 18 POSITION
0001A			P13, P30
0002	00035.000	0996236-0001	CONTACT, RCPT, .025SQ POST .000015G/P THK
0003	00000.330	0996249-0001	CABLE, ELECTRICAL 9 CONDUCTOR, FLAT
0004	00001.000	0996497-0001	KEYING PLUG CONNECTOR

2206535

NOTES UNLESS OTHERWISE SPECIFIED
 [1] INSTALL KEY, ITEM 7, IN P3 PIN 19 AND IN P31 PIN 2
 [2] MARK PER 2265070 LINE FOUR TEXT "CURRENT LOOP/EIA"

WIRE NO.	DESCRIPTION	START STATION	FINISH STATION	SIGNATURE	ITEM NO.	REMARKS
1		WI P3-1	IJ1-4	RTS		
2		WI P3-2	IJ1-11	SRTS		
3		WI P3-3	IJ1-12	SRLSD		
4		WI P3-4	IJ1-6	DSR		
5		WI P3-5	IJ1-22	RI		
6		WI P3-6	IJ1-2	TXD		
7		WI P3-7	IJ1-7	SIG GND		
8		WI P3-8	IJ1-20	DTR		
9		WI P3-9	IJ1-3	RCD		
10		WI P3-10	IJ1-8	RLSD		
11		WI P3-11	IJ1-5	CTS		
12		WI P3-12	IJ1-1	SFTY GND		
13		WI P3-24	IJ1-23	RS		
14		W2 P31-3	IJ1-9	RLSD		
15		W2 P31-4	IJ1-10	RI		
16		W2 P31-5	IJ1-13	DSR		
17		W2 P31-6	IJ1-14	TXD		
18		W2 P31-7	IJ1-16	RCD		
19		W2 P31-8	IJ1-17	RS		
20		W2 P31-11	IJ1-18	RTS		
21		W2 P31-12	IJ1-19	CTS		
22		W2 P31-13	IJ1-21	DTR		
23		W2 P31-14	IJ1-25	SRTS		
24		W2 P31-15	IJ1-24	SRLSD		
25		W2 P31-1	IJ2-1	TXDCURIN		
26		W2 P31-10	IJ2-2	TXDCURO		
27		W2 P31-18	IJ2-5	RXDCURIN		
28		W2 P31-9	IJ2-4	RXDCURO		

REV	DESCRIPTION	DATE	APPROVED
A	CN44405B Schoppert	8-21-79	D. Stamer

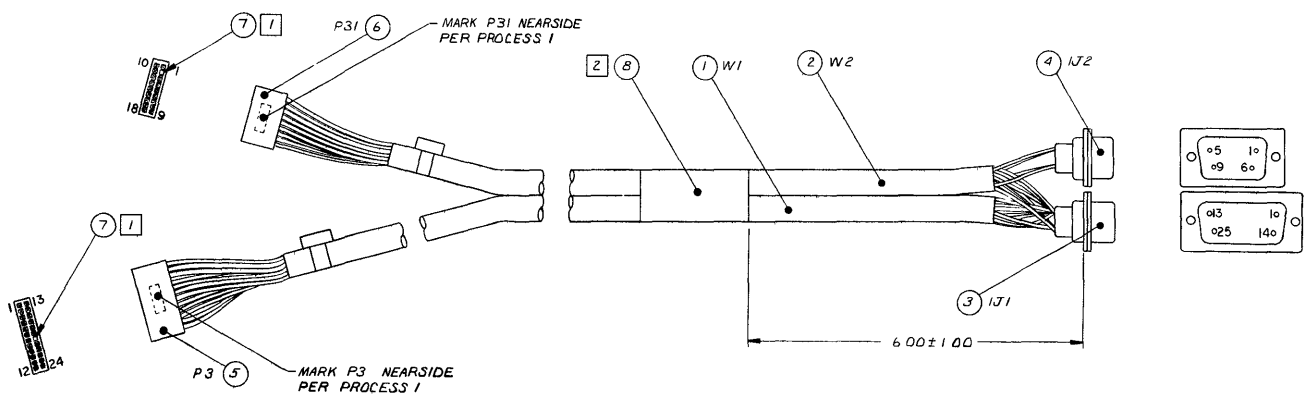

6-176

1	MAK	100-07	712	COLOR WHITE TYPE 9
SEC NO	ID	F SPEC	NO	ADDITIONAL
PROCESS		CLASSIFICATION		

-1	ITEM NO	PART OR IDENTIFYING NUMBER	NOMENCLATURE OR DESCRIPTION	PROCUREMENT SPECIFICATION	NOTES
UNLESS OTHERWISE SPECIFIED			PARTS LIST		
<ul style="list-style-type: none"> DIMENSIONS ARE IN INCHES TOLERANCES ANGLES 11° 3 PLACE DECIMALS = 010 2 PLACE DECIMALS = 02 INTERPRET DRAWINGS PER MIL-D-1002 REMOVE ALL BURRS AND SHARP EDGES CONCENTRICITY MACHINED DIAMETERS .010 FIM DIMENSIONAL LIMITS APPLY BEFORE PROCESSES PARENTHEThICAL INFO FOR REF ONLY 			DATE: 5-25-79 DRAWN: D. Stamer CHECKED: D. Stamer DATE: 8-22-79 DATE: 8-23-79 DATE: 8-23-79 DATE: 8-23-79		
HOLE TOLERANCE			TEXAS INSTRUMENTS INCORPORATED DALLAS, TEXAS CABLE ASSEMBLY, CURRENT LOOP/EIA		
013 THRU + .008 125 THRU + .001 501 THRU + .008 750 THRU + .001			.251 THRU + .006 500 THRU + .001 1.001 THRU + .012 2.000 THRU + .001		
APPLICATION			D96214 SCALE NONE		

PROCESSES — FOR CORRELATION TO GOVT/IND SPECIFICATIONS SEE TI DRAWING 729467

2206548 8740 APPLICATION USED ON

8

7

6

5

4 34

3

2

LM

1

5

D

22

C

B

A

LIST OF MATERIALS

DATE 08-06-79
P/N 2206535

Cable Assembly, Current Loop/EIA

000 1
REV A

PRINT ITEM NUMBER	QUANTITY PER ASSEMBLY	PART NUMBER	DESCRIPTION
0001	00001.000	2206544-0001	ASSEMBLY CABLE 820 OPTIONS-13 CONNECTOR
0001A			W1
0002	00001.000	2206544-0002	ASSEMBLY, CABLE, (820 OPTIONS)-15 CONN
0002A			W2
0003	00001.000	0539409-0006	CONNECTOR, RCPT 25 PINS
0003A			1J1
0004	00001.000	0539409-0002	CONNECTOR, RCPT 9 PINS
0004A			1J2
0005	00001.000	0972202-0025	CONNECTOR, .100 CENTER DUAL MINILATCH
0005A			P3
0006	00001.000	0972202-0028	CONN, .100 CTR DUAL MINILATCH, 18 CAVITIES
0006A			P31
0007	00002.000	0800335-0001	KEY, POLARIZATION, CONNECTOR
0008	00001.000	2210317-0001	LABEL, BLANK, CABLE MARKER
0009	REF	2265070-9901	SPEC, PRODUC & INSTAL, PRE-PRT CBL MARKER\$
0010	REF	2206731-0001	TEST PROGRAM, CURRENT LOOP/EIA CABLE

LIST OF MATERIALS

DATE 08-20-79
P/N 2207630

Multiple Configuration Option

000 1
REV A

PRINT ITEM NUMBER	QUANTITY PER ASSEMBLY	PART NUMBER	DESCRIPTION
0001	REF	2207629-9701	MNL,PROC,INSTL,CONFIG PROM
0002	00002.000	2207628-0001	IC,PROM,PROGRAMMED CONFIG
0002A			U24,U45
0003	REF	0999931-0001	LABEL,CONFIGURATION PROM KIT

DATE 08-20-79
P/N 2207630

000 2
REV A

PRINT ITEM NUMBER	QUANTITY PER ASSEMBLY	PART NUMBER	DESCRIPTION
0001	00001.000	2207629-9701	MNL,PROC,INSTL,CONFIG PROM
0002	00002.000	2207628-0002	IC, PROM, PROGRAMMED CONFIG
0002A			U24,U45
0003	00001.000	0999931-0001	LABEL,CONFIGURATION PROM KIT

DATE 08-20-79
P/N 2207630

000 8001
REV A

PRINT ITEM NUMBER	QUANTITY PER ASSEMBLY	PART NUMBER	DESCRIPTION
0001	00001.000	2207629-9701	MNL,PROC,INSTL,CONFIG PROM
0002	00002.000	2207628-0001	IC,PROM,PROGRAMMED CONFIG
0002A			U24,U45
0003	00001.000	0999931-0001	LABEL,CONFIGURATION PROM KIT

DATE 08-20-79
P/N 2207630

000 8002
REV A

PRINT ITEM NUMBER	QUANTITY PER ASSEMBLY	PART NUMBER	DESCRIPTION
0001	00001.000	2207629-9701	MNL,PROC,INSTL,CONFIG PROM
0002	00002.000	2207628-0002	IC, PROM, PROGRAMMED CONFIG
0002A			U24,U45
0003	00001.000	0999931-0001	LABEL,CONFIGURATION PROM KIT

APPLICATION		REVISIONS			
NEXT ASSY	USED ON	REV	DESCRIPTION	DATE	APPROVED
999683	8740	A	CN433811 <i>File 8/7/79</i>	9-5-79	<i>D. Steiner</i>
		B	CN 436382 <i>A. Steiner</i>	9-5-79	<i>D. Steiner</i>
		C	CN 444908 <i>File 9/5/79</i>	9-5-79	<i>D. Steiner</i>

999734-8001	20ma NEUTRAL CURRENT LOOP
999734-0001	20ma NEUTRAL CURRENT LOOP
PART NUMBER	DESCRIPTION

NOTE: -8001 KIT IS FOR FIELD INSTALLATION

REV													
SHEET													
REV STATUS OF SHEETS		REV	C										
		SHEET	1										
UNLESS OTHERWISE SPECIFIED • DIMENSIONS ARE IN INCHES • TOLERANCES: ANGLES ±1° 3 PLACE DECIMALS ±.010 2 PLACE DECIMALS ±.02 • PARENTHETICAL INFO FOR REF ONLY	DWN	<i>File</i>	DATE	<i>8/7/79</i>	 TEXAS INSTRUMENTS INCORPORATED Dallas, Texas								
	CHK	<i>Dave Steiner</i>	DATE	<i>9-5-79</i>									
	ENG	<i>Alan Goodrum</i>	DATE	<i>9-5-79</i>	MODIFICATION KIT, 20ma NEUTRAL CURRENT LOOP								
	APP	<i>Conner Sutoc</i>	DATE	<i>9/5/79</i>									
	OP	<i>Bradford</i>	DATE	<i>9/5/79</i>									
	CONTR	<i>Sam Brind</i>	DATE	<i>9/5/79</i>	SIZE	FSCM NO	DRAWING NO	A 96214 999734 FILMED					
	REL	<i>[Signature]</i>	DATE	<i>9/5/79</i>	SCALE		SHEET 1 OF 1						

LIST OF MATERIALS

DATE 8/30/79
P/N 999734

Current Loop Interface Option 820/825

0001
REV C

PRINT ITEM NUMBER	QUANTITY PER ASSEMBLY	PART NUMBER	DESCRIPTION
0001	00001.000	2206532-0001	CURRENT LOOP
0002	00001.000	2206534-0001	SHORTING PLUG, 820
0003	00001.000	2206548-0001	PANEL ASSEMBLY,CURRENT LOOP/FIA
0004	00001.000	2206536-0001	CABLE ASSEMBLY,OPTION POWER
0005	00001.000	0994403-0001	CABLE ASSY, CURRENT LOOP
0006	REF	2206533-9701	INSTALLATION INST.,820 CURRENT LOOP OPT

DATE 8/30/79
P/N 999734

8001
REV C

PRINT ITEM NUMBER	QUANTITY PER ASSEMBLY	PART NUMBER	DESCRIPTION
0001	00001.000	0999734-0001	MODIFICATION KIT, 20 MA NEUT CUR LOOP
0006	00001.000	2206533-9701	INSTALLATION INST.,820 CURRENT LOOP OPT

DWG NO 0999836

SH

05

APPLICATION		REVISIONS			
NEXT ASSY	USED ON	REV	DESCRIPTION	DATE	APPROVED
999683	8740				
999685	8740				
999979	8740				
2207415	8740				
2207408	8740				

22

REV																			
SHEET																			
REV STATUS OF SHEETS	REV																		
	SHEET	1	2	3	4														
UNLESS OTHERWISE SPECIFIED <ul style="list-style-type: none"> DIMENSIONS ARE IN INCHES TOLERANCES: ANGLES $\pm 1^\circ$ 3 PLACE DECIMALS $\pm .010$ 2 PLACE DECIMALS $\pm .02$ PARENTHEetical INFO FOR REF ONLY 	DWN	<i>Jfk</i>	DATE	<i>7/24</i>	 TEXAS INSTRUMENTS INCORPORATED Dallas, Texas	INSTALLATION KIT, DEVICE/FORMS CONTROL													
	CHK	<i>Dave Starnes</i>	<i>7/23/79</i>																
	ENGR	<i>Dennis W Lee</i>	<i>7/30/79</i>																
	APVD	<i>Dennis R. Sutlock</i>	<i>7/30/79</i>																
	QA	<i>Bradford</i>	<i>7/30/79</i>																
CONTR	<i>Jorge Barch</i>	<i>7-30-79</i>	SIZE	FSCM NO	DRAWING NO	0999836	FILMED												
	<i>Chris Villan</i>	<i>7/30/79</i>	A	96214															
			SCALE	NONE		SHEET													

TI-23547

↑ 30

LM

6-182

LIST OF MATERIALS

DATE 07-27-79
P/N 0999836

Device/Forms Control Option

REV 1
*

PRINT ITEM NUMBER	QUANTITY PER ASSEMBLY	PART NUMBER	DESCRIPTION
0001	00001.000	2207626-0001	IC,4096 X 8 BIT PROM TMS 4732 ZA
0001A			U12
0002	REF	2207627-9701	MNL,INSTL PROC DVC/FORMS CONT

DATE 07-27-79
P/N 0999836

REV 8001
*

PRINT ITEM NUMBER	QUANTITY PER ASSEMBLY	PART NUMBER	DESCRIPTION
0001	00001.000	2207626-0001	IC,4096 X 8 BIT PROM TMS 4732 ZA
0001A			U12
0002	00001.000	2207627-9701	MNL,INSTL PROC DVC/FORMS CONT

DWG NO 2206548

REVISIONS			
REV	DESCRIPTION	DATE	APPROVED
A	CN 444055 <i>J. Stamm</i>	8-21-79	<i>D. Stamm</i>

NOTES UNLESS OTHERWISE SPECIFIED
 [] OMIT FLAT WASHER FROM ITEM 7 BETWEEN
 HEX SPACER & ADAPTER PANEL (ITEM 3)

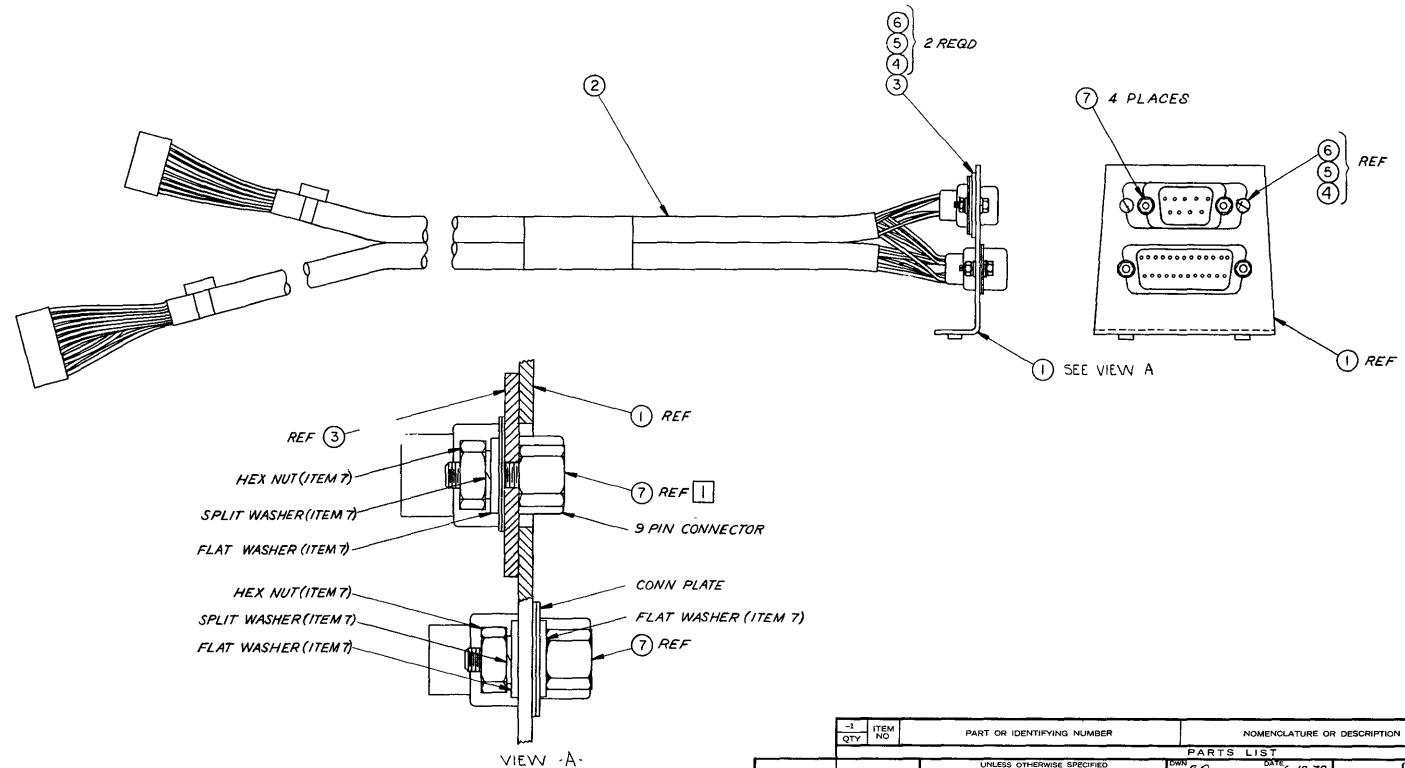

6-184

ITEM QTY	ITEM NO	PART OR IDENTIFYING NUMBER	NOMENCLATURE OR DESCRIPTION	PROCUREMENT SPECIFICATION	NOTES
PARTS LIST					
		UNLESS OTHERWISE SPECIFIED		DATE	
		• DIMENSIONS ARE IN INCHES		6-18-79	
		• TOLERANCES ANGLES ±1°		8-21-79	
		3 PLACE DECIMALS = 010		8-23-79	
		2 PLACE DECIMALS = 02		8-23-79	
		• INTERPRET DRAWING PER MIL D 3000		8-23-79	
		• REMOVE ALL BURRS AND SHARP EDGES		8-23-79	
		• CONCENTRICITY MACHINED DIAMETERS 010 F/M		8-23-79	
		• DIMENSIONAL LIMITS APPLY BEFORE PROCESSES		8-23-79	
		• PARENTHEetical INFO FOR REF ONLY		8-23-79	
		HOLE TOLERANCE		DATE	
		013 THRU .024		8-23-79	
		125 .025		8-23-79	
		400 THRU .051		8-23-79	
		501 .052		8-23-79	
		751 THRU .102		8-23-79	
		752 .103		8-23-79	
		1.001 THRU 1.012		8-23-79	
		2.000 THRU 2.001		8-23-79	
999734	8740				
NEXT ASSY	USED ON				
APPLICATION					

SEQ NO	IDENT	F SPEC	NO	ADDITIONAL	NOTES
	PROCESS			CLASSIFICATION	

PROCESSES - FOR CORRELATION TO GOVT/IND SPECIFICATIONS SEE TI DRAWING 729467

TEXAS INSTRUMENTS
INCORPORATED
Dallas Texas

**PANEL ASSEMBLY,
CURRENT LOOP/EIA**

DATE: 8-23-79
DRAWING NO: 2206548
SCALE: NONE
SHEET: 1

FILMED

LIST OF MATERIALS

Panel Assembly, Current Loop/ EIA

DATE 08-06-79
P/N 2206548

000 1
REV A

PRINT ITEM NUMBER	QUANTITY PER ASSEMBLY	PART NUMBER	DESCRIPTION
0001	00001.000	0999743-0001	PANEL, EIA CABLE
0002	00001.000	2206535-0001	CABLE ASSEMBLY,CURRENT LOOP/EIA
0003	00001.000	0999788-0002	ADAPTER, EIA CONNECTOR PANEL (9 PIN)
0004	00002.000	0972988-0014	SCREW 4-40 X .312 PAN HEAD CRES
0005	00002.000	0416622-0011	WASHER #4 FLAT
0006	00002.000	0411104-0135	WASHER, LOCK-SPRING, HELICAL, #4
0007	00004.000	0808129-0001	CONNECTOR,ELECT SCREW-LOCK ASSY FEMALE

DWG NO 2206532

REV 1 5

REV	DESCRIPTION	DATE	APPROVED
A	CN 43855 R Raman 7-23-79	8-22-79	D Bluman
B	CN 444952 J Bluman 8-21-79	8-22-79	D Bluman

NOTES UNLESS OTHERWISE SPECIFIED

- 1 MARK SITE DATE CODE ON ASSEMBLY IN POSITION INDICATED PER 994396 (ITEM 34) PARAGRAPH 4.0 USING PROCESS I
- 2 MARK APPROPRIATE REVISION LETTER PER PROCESS LETTER PER PROCESS I
- 3. MAXIMUM LEAD LENGTH BELOW SURFACE OF BOARD .07
- 4 INSTALL JUMPER PLUGS (ITEM 32) ONTO 2 & 6 AND 4 & 8 ON BOTH J32 AND J33 FOR PASSIVE CURRENT LOOP OPERATION
- 5 REMOVE PIN 2 FROM J31 (ITEM 30) FOR MATING CONNECTOR KEY

[REFERENCE ONLY; FOR ACTIVE CURRENT LOOP OPTION RELOCATE JUMPER PLUGS TO PINS 1 & 5 AND 3 & 7 ON BOTH J32 AND J33]

6-186

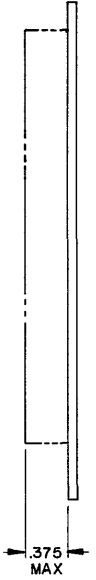
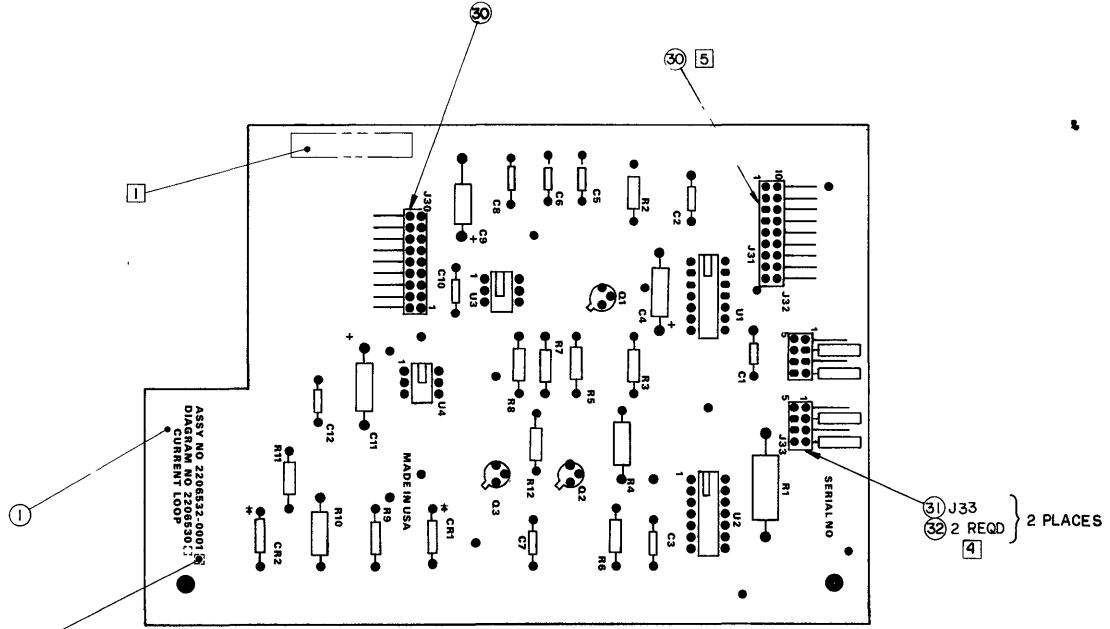

2	SLDR	124-02	00	HEIGHT: .06, COLOR: BLACK	
1	MARK	100-02	21		

ITEM QTY	ITEM NO	PART OR IDENTIFYING NUMBER	NOMENCLATURE OR DESCRIPTION	PROCUREMENT SPECIFICATION	NOTES
PARTS LIST					
<p>UNLESS OTHERWISE SPECIFIED</p> <ul style="list-style-type: none"> • DIMENSIONS ARE IN INCHES • TOLERANCES - ANGLES - 1° • 3 PLACE DECIMALS = .010 • 2 PLACE DECIMALS = .03° • INTERPRET DRAWINGS PER MIL D 1000 • REMOVE ALL BURRS AND SHARP EDGES • CONCENTRICITY MACHINED DIAMETERS .010 FAV • DIMENSIONAL LIMITS APPLY BEFORE PROCESSES • PARENTHESES INFO FTH OFF ONLY 					
			DATE	TEXAS INSTRUMENTS INCORPORATED Dallas, Texas	
				CURRENT LOOP	
999734		8740			
NEXT ASSY USED ON			DATE	DRAWING NO	
APPLICATION			21	2206532	
			SIZE	LM	

PROCESSES — FOR CORRELATION TO GOVT/IND SPECIFICATIONS, SEE TI DRAWING 72467

LIST OF MATERIALS

DATE 08-21-79
P/N 2206532

PWB Assembly, Current Loop

000 1
REV B

PRINT ITEM NUMBER	QUANTITY PER ASSEMBLY	PART NUMBER	DESCRIPTION
0001	00001.000	2206531-0001	PWB, CURRENT LOOP
0002	REF	2206530-0001	DIAGRAM, LOGIC, CURRENT LOOP
0003	00001.000	0996015-0001	IC, QUAD LINE DRIVERS SN75188N
0003A			U1
0004	00001.000	0972450-0002	NETWORK, SN75189AN/MC1489AL QUAD LINE RCR SEE
0004A			U2
0006	00001.000	0971000-0001	IC, OPTICALLY COUPLED ISOLATOR
0006A			U3
0007	00001.000	0972625-0001	NETWORK OC1449 OPTICALLY COUPLED
0007A			U4
0009	00002.000	0972057-0001	TRANSISTOR-A5T2222 NPN SILICON
0009A			Q1, Q2
0010	00001.000	0772637-0006	TRANSISTOR, T1S99
0010A			Q3
0012	00001.000	0539468-0003	DIODE, 1N4003 1AMP 200PIV RECTIFIER
0012A			CR1
0013	00001.000	0972934-0006	DIODE, 1N751A 5.1 V 5% SIL VOLT REG
0013A			CR2
0014	00001.000	0972946-0041	RES FIX 100 OHM 5% .25 W CARBON FILM
0014A			R8
0015	00002.000	0972946-0045	RES FIX 150 OHM 5% .25 W CARBON FILM
0015A			R2, R11
0016	00001.000	0972946-0050	RES FIX 240 OHM 5% .25 W CARBON FILM
0016A			R3
0017	00002.000	0972946-0065	RES FIX 1.0K OHM 5% .25 W CARBON FILM
0017A			R6, R9
0021	00001.000	0972947-0037	RES FIX 68 OHM 5% .5 W CARBON FILM
0021A			R10
0022	00001.000	0972947-0041	RES FIX 100 OHM 5% .5 W CARBON FILM
0022A			R4
0024	00001.000	0972978-0083	RES FIX COMP 1.0 W 180 OHMS 5%
0024A			R1
0025	00002.000	0972946-0137	RES FIX 1.0M OHM 5% .25 W CARBON FILM
0025A			R7, R12
0026	00008.000	0972763-0021	CAP., FIXED, AXIAL LEAD, .047 UF, +80%, -20%
0026A			C1, C2, C3, C5, C6, C7, C8, C10
0027	00003.000	0972924-0014	CAP FIX TANT SOLID 15 MFD 10% 20 VOLT

LIST OF MATERIALS

DATE 08-21-79
P/N 2206532

PWB Assembly, Current Loop

000 1
REV B

PRINT ITEM NUMBER	QUANTITY PER ASSEMBLY	PART NUMBER	DESCRIPTION
0027A			C4,C9,C11
0028	00001.000	0410529-0203	CAP FIX CERAMIC .02UF +80%-20% 600 V
0028A			C12
0030	00002.000	2210451-0003	HEADER, RIGHT ANGLE, DCUBLE ROW, 18 POS
0030A			J30,J31
0031	00002.000	2210451-0002	HEADER, RIGHT ANGLE, DOUBLE ROW, 8 POS
0031A			J32,J33
0032	00004.000	0972487-0001	JUMPER PLUG,CONNECTOR BLACK
0033	00001.000	0972946-0057	RES FIX 470 OHM 5 % .25 W CARBON FILM
0033A			R5
0034	REF	0994396-9901	PROCEDURE,SITE & DATE CODE SERIALIZATION

6-189

NOTES, UNLESS OTHERWISE SPECIFIED

- 1 CABLE CLAMP SCREWS AND RETAINER CLIPS AND SCREWS INCLUDED WITH (ITEM 4)
- 2 RETAINER CLIP INSTALLED WITH THREADED HOLE ON SAME SIDE AS TREEW HEAD
- 3 SCREWS MUST BE THREADED COMPLETELY THRU RETAINER CLIPS

WIRE NO	DESCRIPTION	START STATION	FINISH STATION	SIGNATURE	ITEM NO	REMARKS
1	22 AWG IPVC WHT	PI-4	PI-18	RTS	3	
2		-11	-25	SRTS		
3		-12	24	SRLSD		
4		-6	13	DSR		
5		-22	10	RI		
6		-2	14	TXD		
7		-20	21	DTR		
8		-3	16	RCD		
9		-8	9	RLSD		
10		-5	19	CTS		
11	22 AWG IPVC WHT	PI-23	PI-17	RS	3	

REVISIONS			
REV	DESCRIPTION	DATE	APPROVED

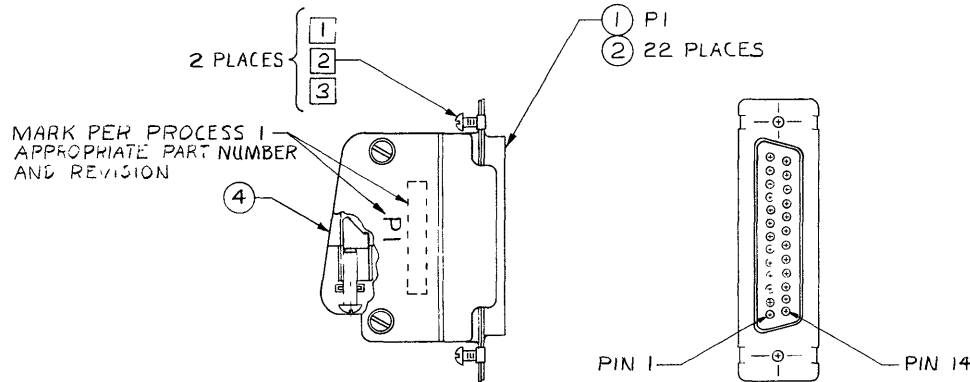

MARK PER PROCESS 1 APPROPRIATE PART NUMBER AND REVISION

QTY	ITEM NO	PART OR IDENTIFYING NUMBER	NOMENCLATURE OR DESCRIPTION	PROCUREMENT SPECIFICATION	NOTES
PARTS LIST					
<small>UNLESS OTHERWISE SPECIFIED</small> • DIMENSIONS ARE IN INCHES • TOLERANCES ANGLES ±1° • 3 PLACE DECIMALS = 010 • 2 PLACE DECIMALS = 02 • INTERPRET DRAWING PER MIL-D-1000 • REMOVE ALL BURRS AND SHARP EDGES • CONCENTRICITY MACHINED DIAMETERS .010 FIM • DIMENSIONAL LIMITS APPLY BEFORE PROCESSES • PARENTHETICAL INFO FOR REF ONLY					
999734	8740	013 + 004 125 + 005 291 + 006 125 + 001 250 + 001 500 + 001 501 750 1001 THRU + 008 THRU + 010 THRU + 012 750 + 001 1000 + 001 2000 + 001	DIMS: M. Omick 4-2-79 CHK: M. Omick 8-15-79 TRNG: M. Omick 8-22-79 APPR: Mark 8-24-79 DATE: 8-24-79 CORR: M. Omick 8-22-79 DATE: 8-22-79	TEXAS INSTRUMENTS INCORPORATED Dallas, Texas	SHORTING PLUG, 820 SIZE: FSCM NO. C 96214 DRAWING NO. 2206534 SCALE: NONE SHEET

1	MARK	100-07	12	COLOR WHT. TYPE 9	
SEQ NO	IDENT	F-SPEC	NO	ADDITIONAL CLASSIFICATION	NOTES

PROCESSES — FOR CORRELATION TO GOVT/IND SPECIFICATIONS SEE TI DRAWING 729467

TI 9925H

4

3

30

2

LM 1

FILE

DRAWING NO. 2206534

LIST OF MATERIALS

Shorting Plug, 820

DATE 08-06-79
P/N 2206534

000 1
REV A

PRINT ITEM NUMBER	QUANTITY PER ASSEMBLY	PART NUMBER	DESCRIPTION
0001	00001.000	0539409-0005	CONNECTOR, PLUG 25 PINS
0001A			P1
0002	00022.000	0539430-0003	CONTACT, PIN 24-20AWG .068 INSUL DIA
0003	00003.000	0538347-3999	WIRE HOOKUP B-22 AWG 19 STR WHITE
0004	00001.000	0539903-0001	HOOD, CONN 25 PIN WITH RETAINERS
0005	REF	2207632-0001	FAULT FINDER TEST PROGRAM

SECTION VII DIAGRAMS

This section contains the logic diagrams for the Model 820 KSR and RO major assemblies.

TI Drawing No.	Title	Page No.
999710	ASCII Keyboard (KSR)	7-3
999945	Terminal Electronics	7-5
999951	Operator's Panel (RO)	7-19
2206530	Current-Loop Electronics	7-21

REV	DESCRIPTION	DATE	APPROVED
E	CN445413	1/3/79	[Signature]

NOTES UNLESS OTHERWISE SPECIFIED

- 1. ALL RESISTORS ARE .25 WATT, 5 PCT
- 2. R10 THROUGH R16 ARE 220 OHMS
- 3. C2 THROUGH C6 ARE +80/-20 PCT
- 4. CR72 IS "XMIT" LED
- 5. CR74 IS "CARR" LED
- 6. USED ONLY ON APL KEYBOARD
- 7. USED ONLY ON NUMERIC CLUSTER OPTIONS
- 8. RESERVED FOR FUTURE EXPANSION

D

C

7-3

B

A

23

C

B

A

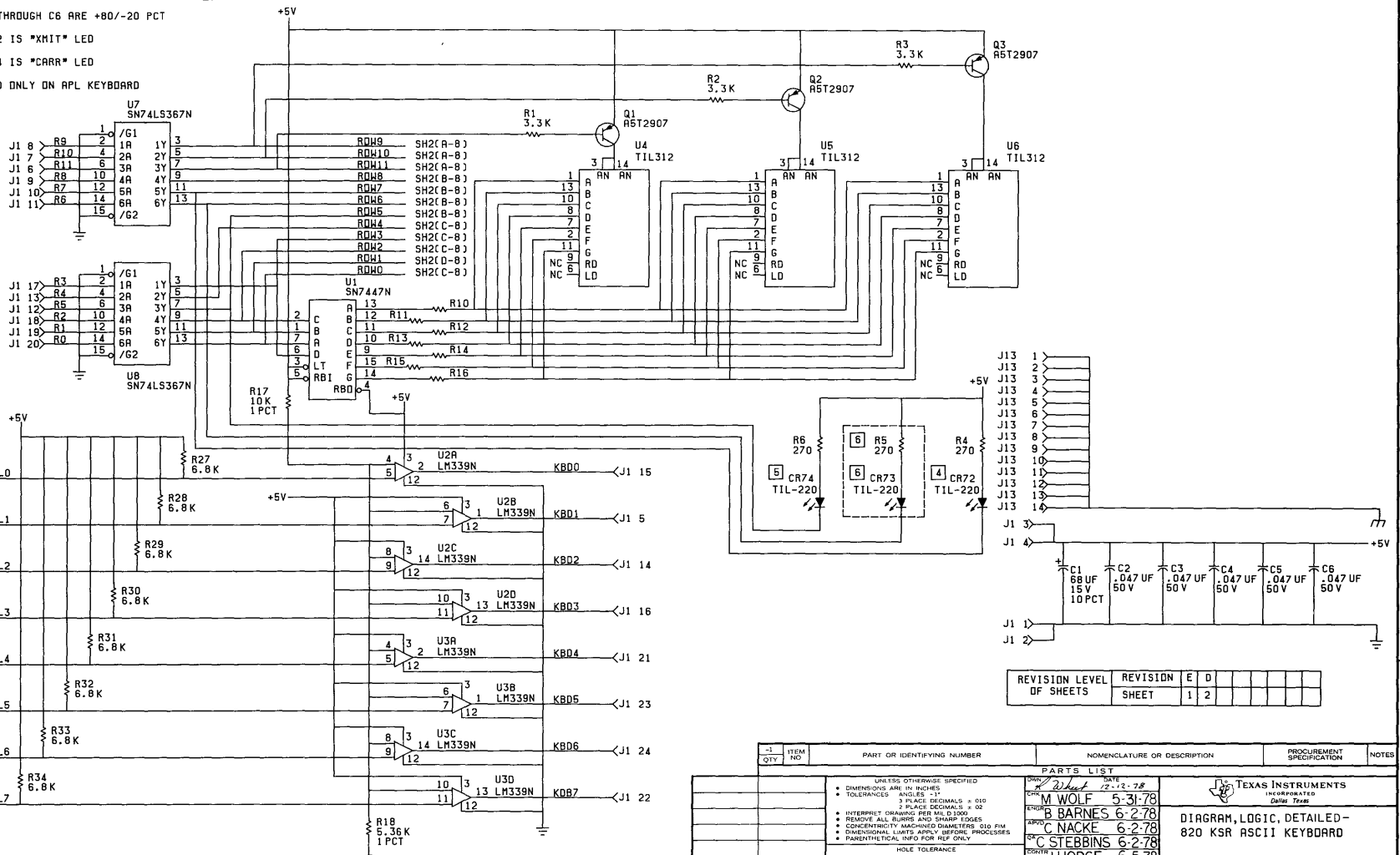

REVISION LEVEL OF SHEETS	REVISION SHEET	E	D				
	1	2					

ITEM NO	PART OR IDENTIFYING NUMBER	NOMENCLATURE OR DESCRIPTION	PROCUREMENT SPECIFICATION	NOTES
8740	U1	SN7447N		
	U2A-U2G	LM339N		
	U3A-U3D	LM339N		
	U4, U5	TIL312		
	U6	TIL312		
	U7, U8	SN74LS367N		
	R1-R34	RESISTORS		
	C1-C6	CAPACITORS		
	CR72, CR73, CR74	LEDs		

SEQ NO	IDENT	F SPEC	NO	ADDITIONAL CLASSIFICATION	NOTES

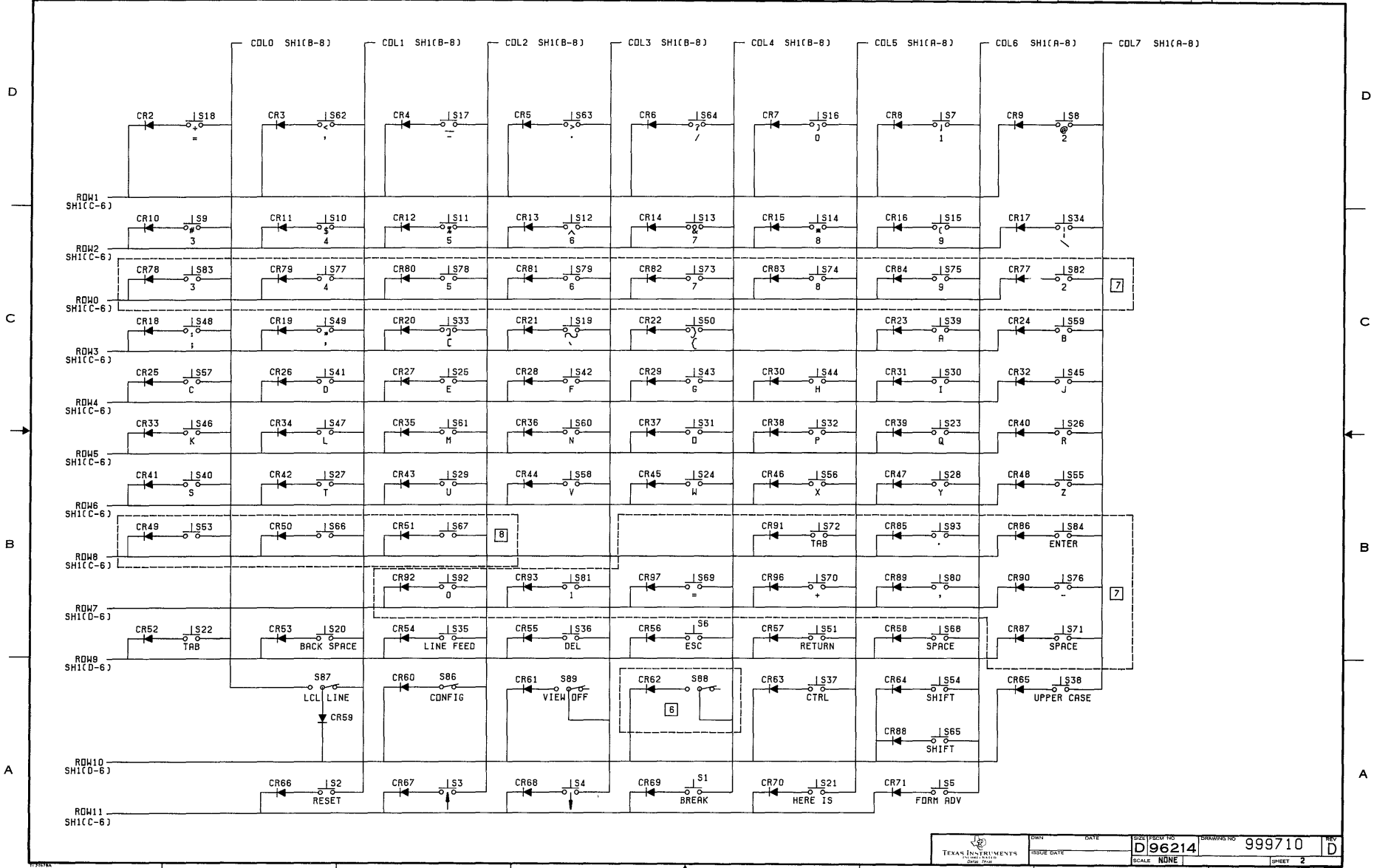

NOTES: UNLESS OTHERWISE SPECIFIED
 1. RESISTANCE VALUES ARE IN OHMS
 2. RESISTORS ARE .25 W, 5 PCT
 3. CAPACITORS ARE .+80-20 PCT
 4. DIODES ARE 1N4002
 5. FOR POWER AND GROUND PINS SEE TABLE ON SHEET 11

PROCESSOR SECTION REFERENCE DESIGNATORS		
FIRST USED	LAST USED	UNUSED
E1	E29	
R1	R37	
C1	C23	
CR1	CR3	
Q1	Q6	
U1	U45	

PRIMARY PWR SUPPLY REFERENCE DESIGNATORS		
FIRST USED	LAST USED	UNUSED
E250	E286	E270, E272 - E280, E283, E284
R250	R275	
C250	C264	
CR250	CR266	
Q250	Q255	

REVISIONS			
REV	DESCRIPTION	DATE	APPROVED
A	CN451048 JB Lencaster	6-14-79	Nan Steiner
FORMAL RELEASE			
B	CN438093 C. K...	6/20/79	Nan Steiner

DRIVER REFERENCE DESIGNATORS		
FIRST USED	LAST USED	UNUSED
E101	E117	E105 - E111
R101	R143	R136
C101	C108	
CR101	CR139	
Q101	Q119	Q112, Q118
U101	U113	U111

SECONDARY PWR SUPPLY REFERENCE DESIGNATION		
FIRST USED	LAST USED	UNUSED
E200	E235	E217, E218, E224 - E226
R200	R233	R201, R211, R212, R230
C200	C215	C214
CR201	CR211	CR208
Q201	Q205	Q204
U201	U206	U204

E20 → J11 15
 E28 → J13 15

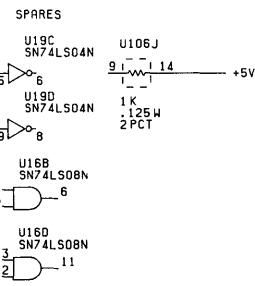
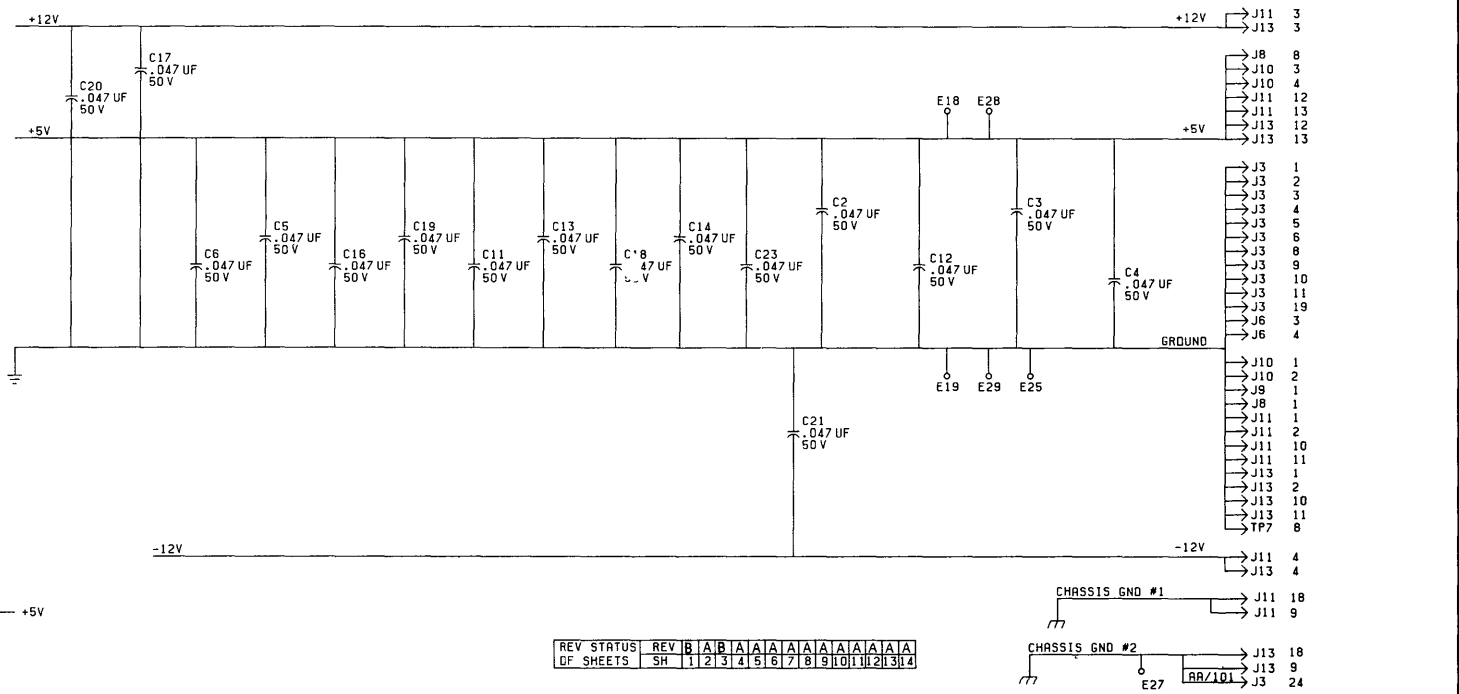

REV	STATUS	REV	BAR	BAR	BAR	BAR	BAR	BAR	BAR	BAR	BAR	BAR	BAR	BAR	BAR	BAR	BAR
1	SH	1	2	3	4	5	6	7	8	9	10	11	12	13	14		

ITEM NO	PART OR IDENTIFYING NUMBER	NOMENCLATURE OR DESCRIPTION	PROCUREMENT SPECIFICATION	NOTES								
1	8740	DIAGRAM, LOGIC, DETAILED TERMINAL ELECTRONICS	INCORPORATED	TEXAS INSTRUMENTS Dallas, Texas								
<table border="1"> <tr> <td>999947</td> <td>8740</td> <td>APPLICATION</td> <td>USED ON</td> </tr> <tr> <td>NEXT ASSY</td> <td>APPLICATIO</td> <td></td> <td></td> </tr> </table>					999947	8740	APPLICATION	USED ON	NEXT ASSY	APPLICATIO		
999947	8740	APPLICATION	USED ON									
NEXT ASSY	APPLICATIO											

SEQ NO	IDENT	F SPEC	NO	ADDITIONAL	NOTES
	PROCESS			CLASSIFICATION	

7-5

23

1 OF 14

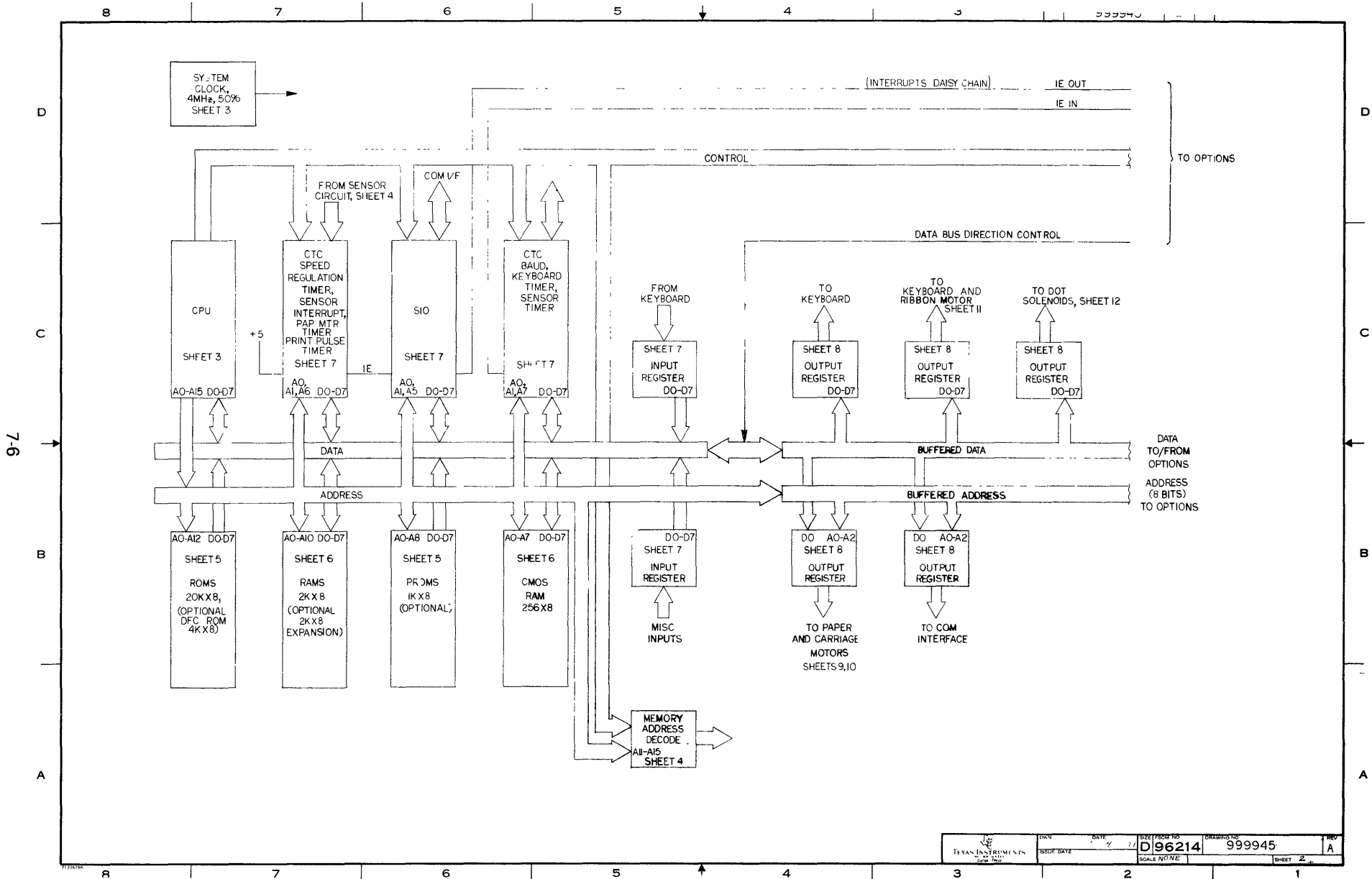

7-6

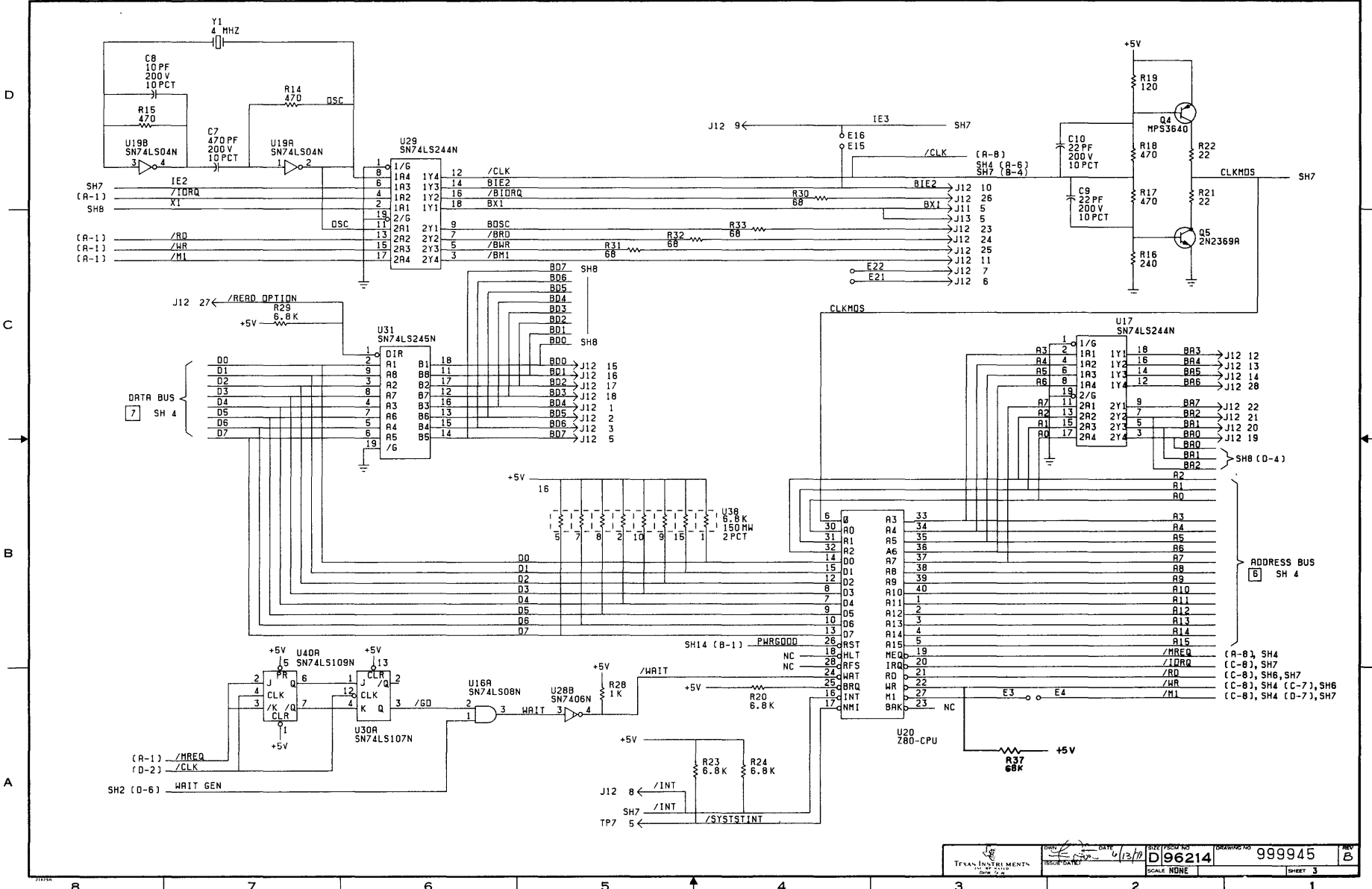

7-7

6 THE ADDRESS BUS APPEARS IN THE FOLLOWING PLACES
 A0,A1 SH3(B-1), SH5(D-8), SH6(D-8), SH7(D-1)
 A2-A4 SH3(B-1), SH5(D-8), SH6(D-8)
 A5-A7 SH3(B-1), SH5(D-8), SH6(D-8), SH7(D-1)
 A8,A9 SH3(B-1), SH5(C-8)(D-8), SH6(D-8)
 A10 SH3(B-1), SH5(C-8), SH6(D-8)
 A11,A12 SH3(B-1), SH4(D-7), SH5(C-8)
 A13-A15 SH3(B-1), SH4(D-7)

7 THE DATA BUS APPEARS IN THE FOLLOWING PLACES
 D0-D7 SH3(C-7), SH5(D-1), SH6(D-8), SH7(D-1)

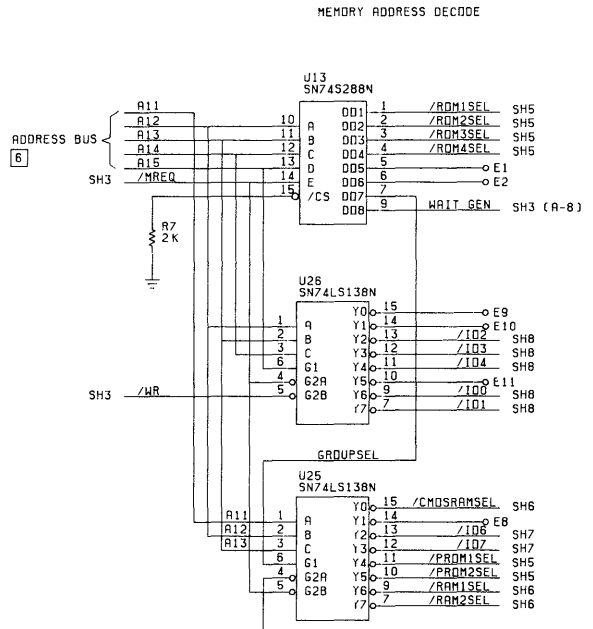

U13 ROM DECODE 74S288

E	D	C	B	A	D8	D7	D6	D5	D4	D3	D2	D1	COMMENTS
0	0	0	0	0	1	0	0	0	1	1	1	0	ROM 1
0	0	0	0	1	1	0	0	0	1	1	1	0	ROM 2
0	0	0	1	0	1	0	0	0	1	1	0	1	ROM 3 (DFCS)
0	0	0	1	1	1	0	0	0	1	1	0	1	ROM 4 (DDTS)
0	0	1	0	0	1	0	0	0	1	1	1	1	PROM 1
0	0	1	0	1	0	1	0	0	1	1	1	1	PROM 2
0	0	1	1	0	1	0	0	1	1	1	1	1	GROUP RAM 1, RAM 2
0	1	0	0	0	1	1	0	0	1	1	1	1	CMDS, -----
0	1	0	0	1	0	1	0	0	1	1	1	1	KB COL IN, BITS IN
0	1	0	1	0	0	0	0	1	1	1	1	1	ID 2 (KB ROWS LS)
0	1	0	1	1	0	0	0	1	1	1	1	1	ID 3 (KB ROWS HS)
0	1	1	0	0	0	0	0	1	1	1	1	1	ID 4 (DDTS)
0	1	1	0	1	0	0	0	0	1	1	1	1	ID 0 (BELL, ETC)
0	1	1	1	0	0	0	0	1	1	1	1	1	ID 1 (PAPER, CARR)
1	0	0	0	0	0	0	0	1	1	1	1	1	
1	0	0	0	1	0	0	0	1	1	1	1	1	
1	0	0	1	0	0	0	0	1	1	1	1	1	
1	0	0	1	1	0	0	0	1	1	1	1	1	
1	0	1	0	0	0	0	0	1	1	1	1	1	
1	0	1	0	1	0	0	0	1	1	1	1	1	
1	0	1	1	0	0	0	0	1	1	1	1	1	
1	0	1	1	1	0	0	0	1	1	1	1	1	
1	1	0	0	0	0	0	0	1	1	1	1	1	
1	1	0	0	1	0	0	0	1	1	1	1	1	
1	1	0	1	0	0	0	0	1	1	1	1	1	
1	1	0	1	1	0	0	0	1	1	1	1	1	
1	1	1	0	0	0	0	0	1	1	1	1	1	
1	1	1	0	1	0	0	0	1	1	1	1	1	
1	1	1	1	0	0	0	0	1	1	1	1	1	
1	1	1	1	1	0	0	0	1	1	1	1	1	

U8 TACH STATE 74S287

CBAR	000	001	010	011	100	101	110	111	
HGFED	0000	0000	0010	0000	0010	1100	1110	1100	1110
00000	0000	0010	0000	0010	1100	1110	1100	1110	
00001	0000	0010	0000	0010	1100	1110	1100	1110	
00010	0000	0010	0000	0010	1100	1110	1100	1110	
00011	0000	0010	0000	0010	1100	1110	1100	1110	
00100	0100	0110	0100	0110	0100	0110	0111	0111	
00101	1001	1001	1000	1010	1000	1010	1000	1010	
00110	0100	0110	0100	0110	0100	0110	0111	0111	
00111	1001	1001	1000	1010	1000	1010	1000	1010	
01000	0000	0010	0000	0010	1100	1110	1100	1110	
01001	0000	0010	0000	0010	1100	1110	1100	1110	
01010	0000	0010	0000	0010	1100	1110	1100	1110	
01011	0000	0010	0000	0010	1100	1110	1100	1110	
01100	0100	0110	0100	0110	0100	0110	0111	0111	
01101	1001	1001	1000	1010	1000	1010	1000	1010	
01110	0100	0110	0100	0110	0100	0110	0111	0111	
01111	1001	1001	1000	1010	1000	1010	1000	1010	
10000	0000	0010	0000	0010	1100	1110	1100	1110	
10001	0000	0010	0000	0010	1100	1110	1100	1110	
10010	0000	0010	0000	0010	1100	1110	1100	1110	
10011	0000	0010	0000	0010	1100	1110	1100	1110	
10100	0000	0010	0000	0010	1100	1110	1100	1110	
10101	0000	0010	0000	0010	1100	1110	1100	1110	
10110	0000	0010	0000	0010	1100	1110	1100	1110	
10111	0000	0010	0000	0010	1100	1110	1100	1110	
11000	0100	0110	0100	0110	0100	0110	0111	0111	
11001	0100	0110	0100	0110	0100	0110	0111	0111	
11010	1001	1001	1000	1010	1000	1010	1000	1010	
11011	1001	1001	1000	1010	1000	1010	1000	1010	
11100	0100	0110	0100	0110	0100	0110	0111	0111	
11101	0100	0110	0100	0110	0100	0110	0111	0111	
11110	1001	1001	1000	1010	1000	1010	1000	1010	
11111	1001	1001	1000	1010	1000	1010	1000	1010	

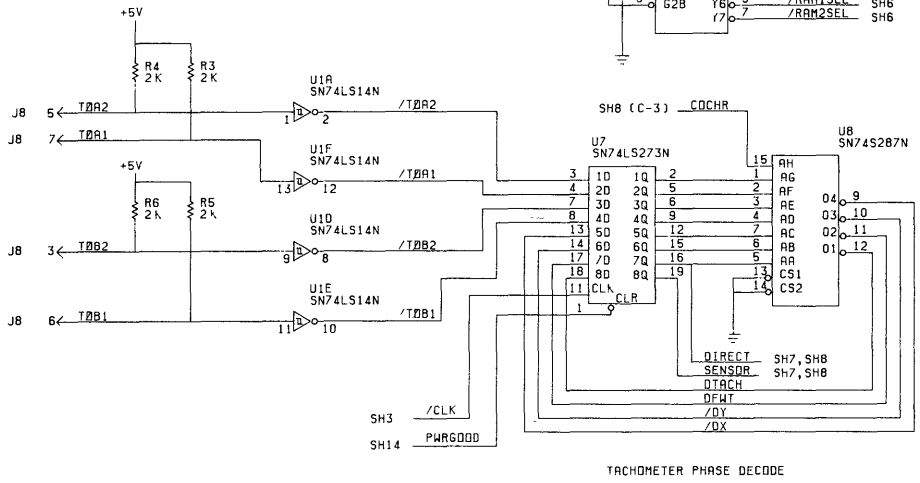

D

D

C

C

B

B

A

A

7-9

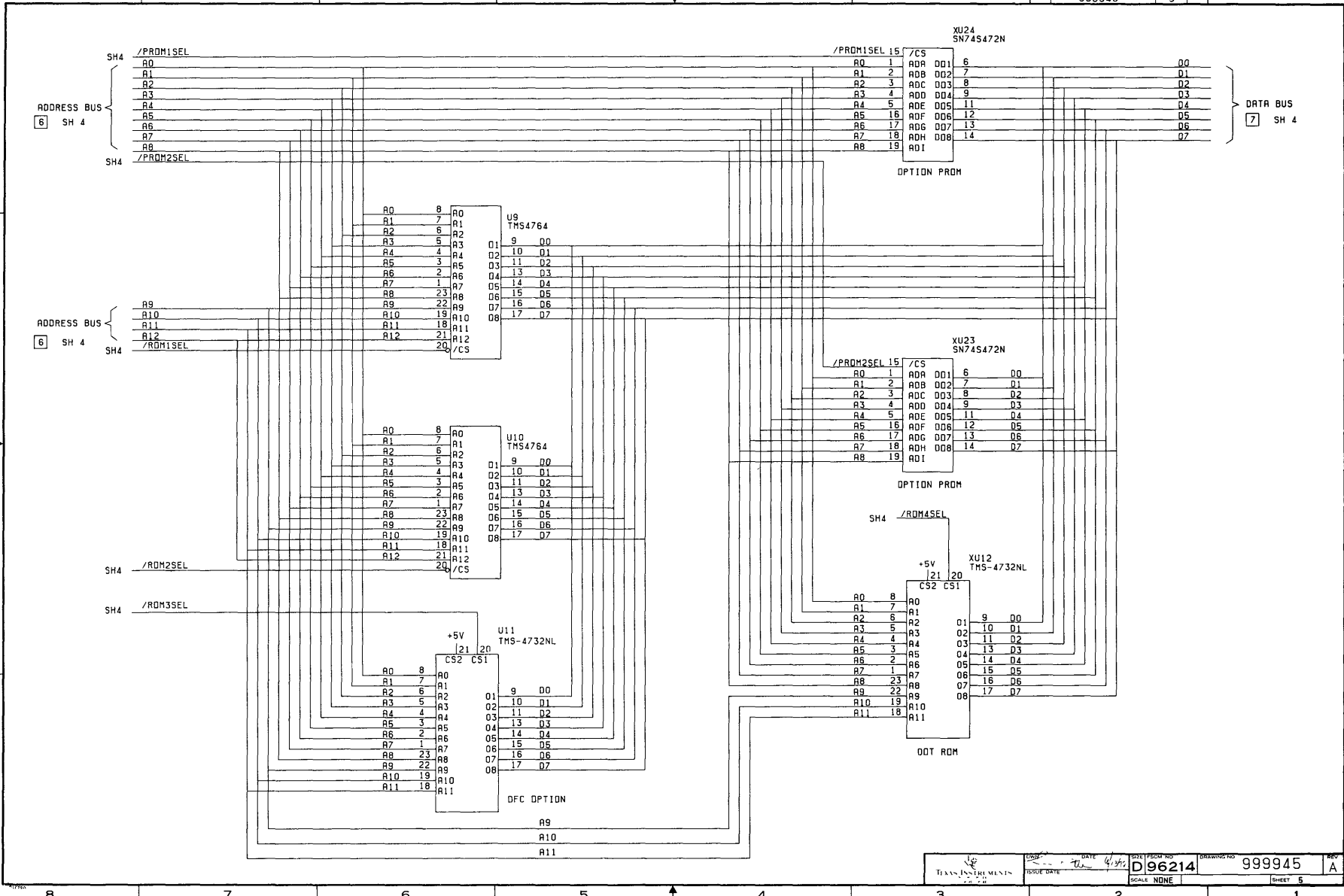

NOTES:
 [8] JUMPER E5 TO E6 WHEN USING MK4118N-4 (1K X 8 RAM) IN LOCATIONS U2 AND U3. E7 FOR FUTURE USE

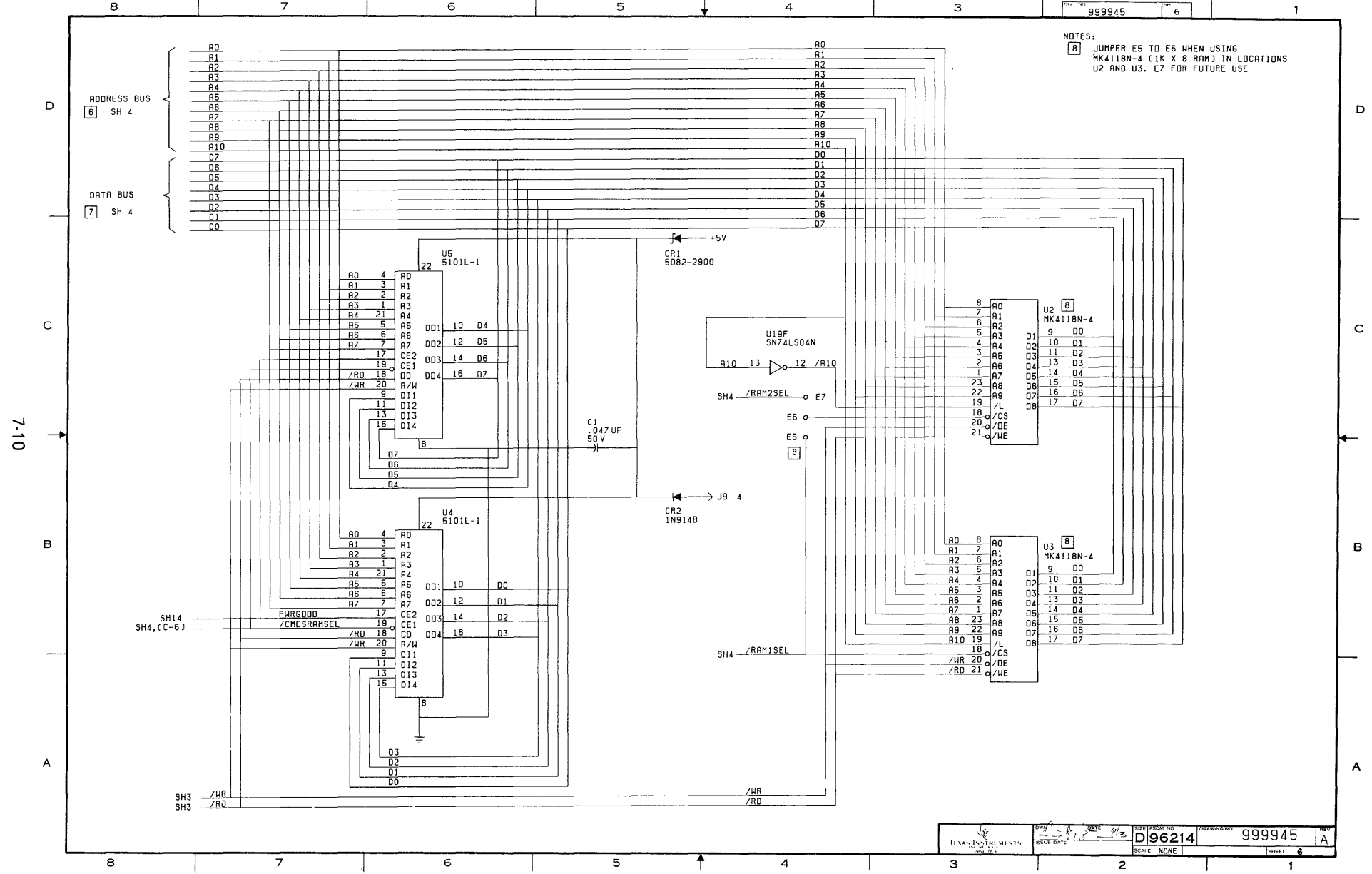

7-10

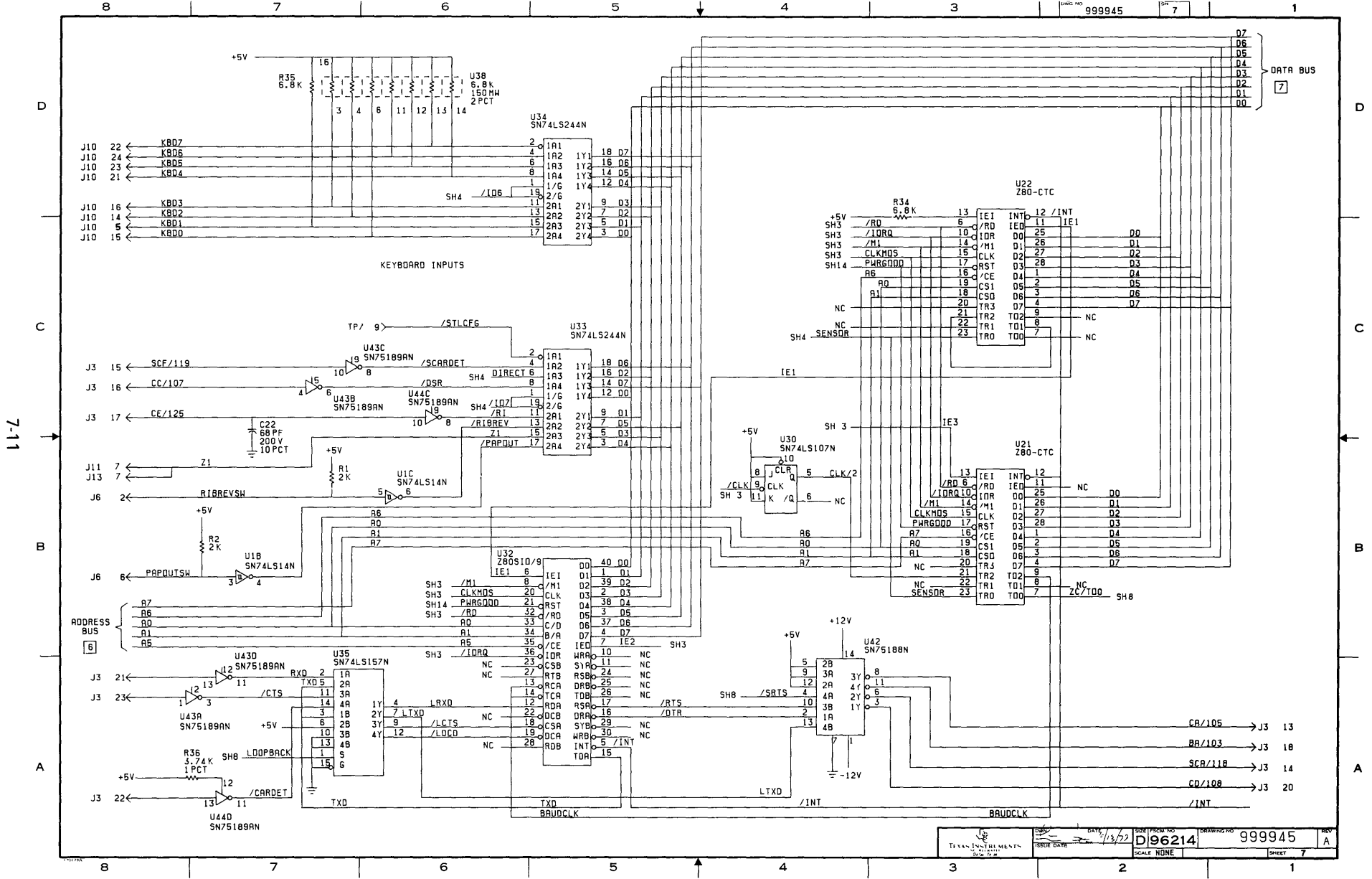

7-11

7-12

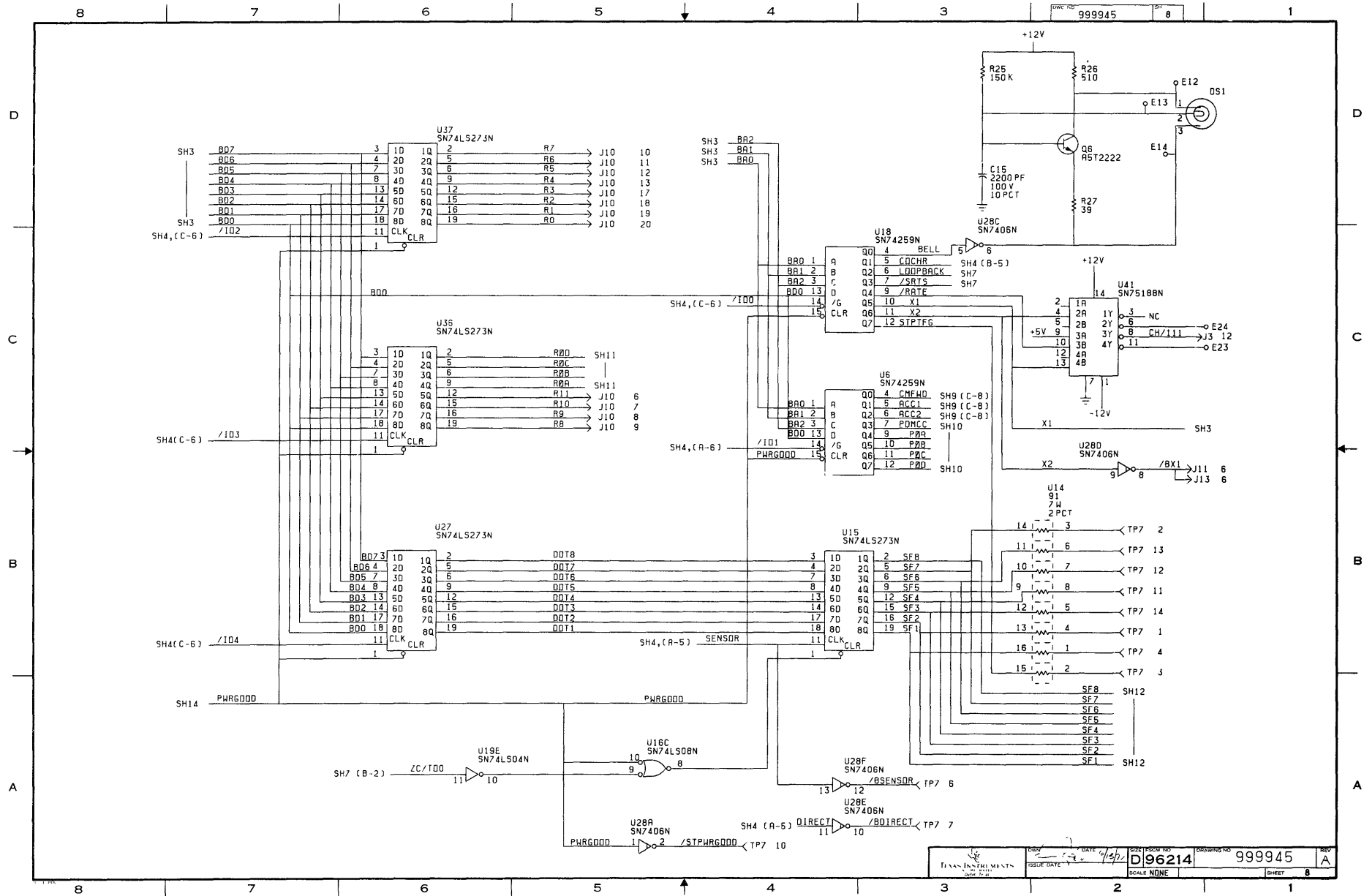

NOTES:

- [9] DENOTES PIN 7 OF U108 IS CONNECTED TO [A]
- [A] DENOTES FIRST +33V MOTOR RETURN WHICH CONNECTS TO CENTRAL POINT GROUND AT POWER SUPPLY SECONDARY
- [10] DENOTES U108-14 CONNECTED TO +5V0VR
- [11] DENOTES HEATSINKS FOR Q105, Q106, Q108, Q109, Q110 AND Q111 ARE CONNECTED TO E103
- [12] DENOTES R125 MUST CONNECT DIRECTLY TO R124 WITH NO OTHER CONNECTIONS BETWEEN THEM

S-B (C-3) CMFWD

SHB (C-3) ACC2

SHB (C-3) ACC1

+5VSW

MOTOR CURRENT TABLE

ACC2	ACC1	INTR
0	0	.66A
0	1	1.43A
1	0	1.43A
1	1	2.86A

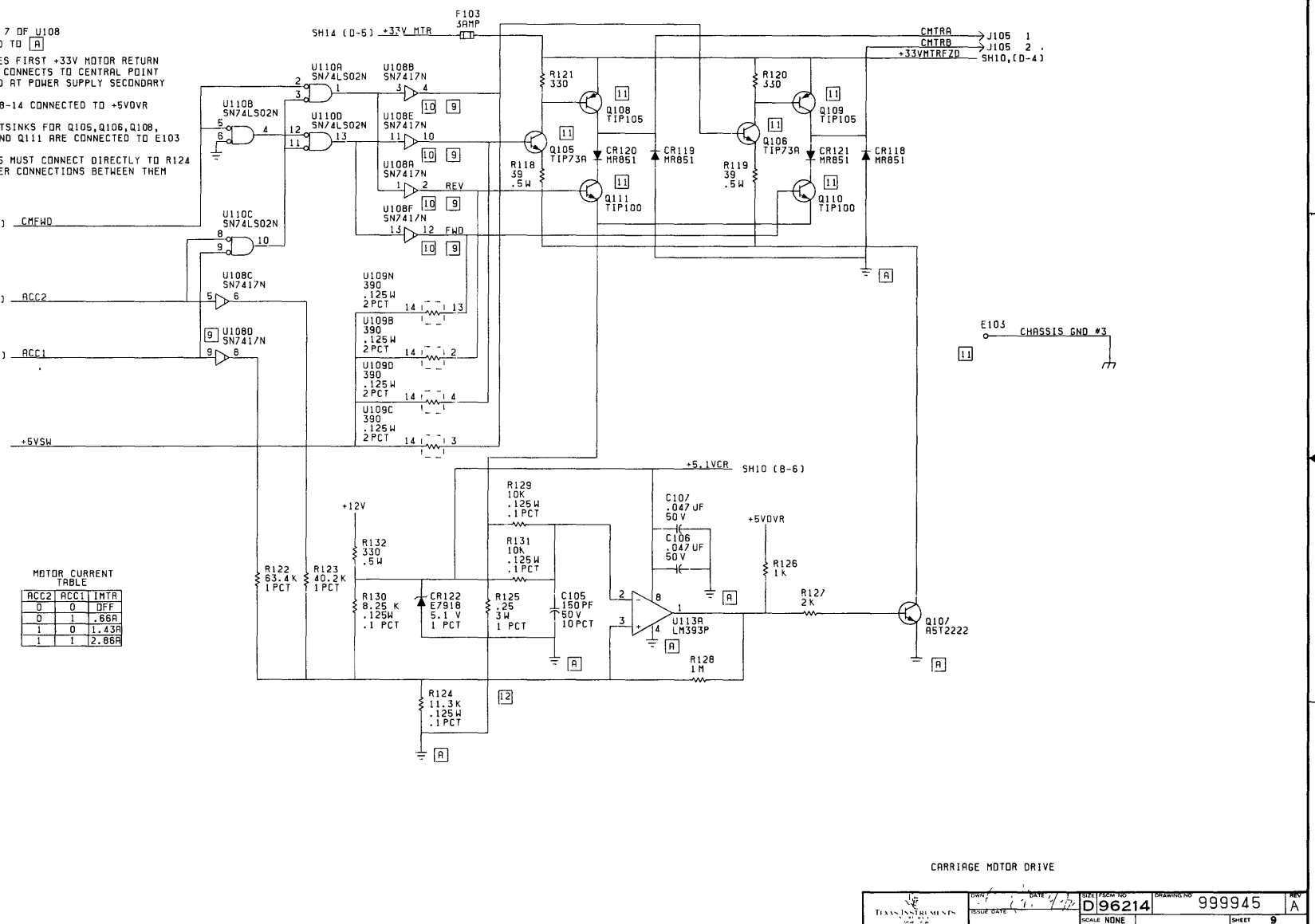

CARRIAGE MOTOR DRIVE

7-13

NOTES:

- 13 U112-14 IS CONNECTED TO +5VDVR
U112-7 IS CONNECTED TO [A]
- [A] DENOTES SECOND +33V MOTOR RETURN WHICH CONNECTS TO CENTRAL POINTS GROUND AT POWER SUPPLY SECONDARY
- 14 HEATSINKS FOR Q113, Q114, Q115, Q116, Q117 AND Q119 ARE CONNECTED TO E102 SH12, (C-4)
- 15 POWER CONNECTION FOR U113 SHOWN ON SH9, (B-4)

D
C
7-14
B
A

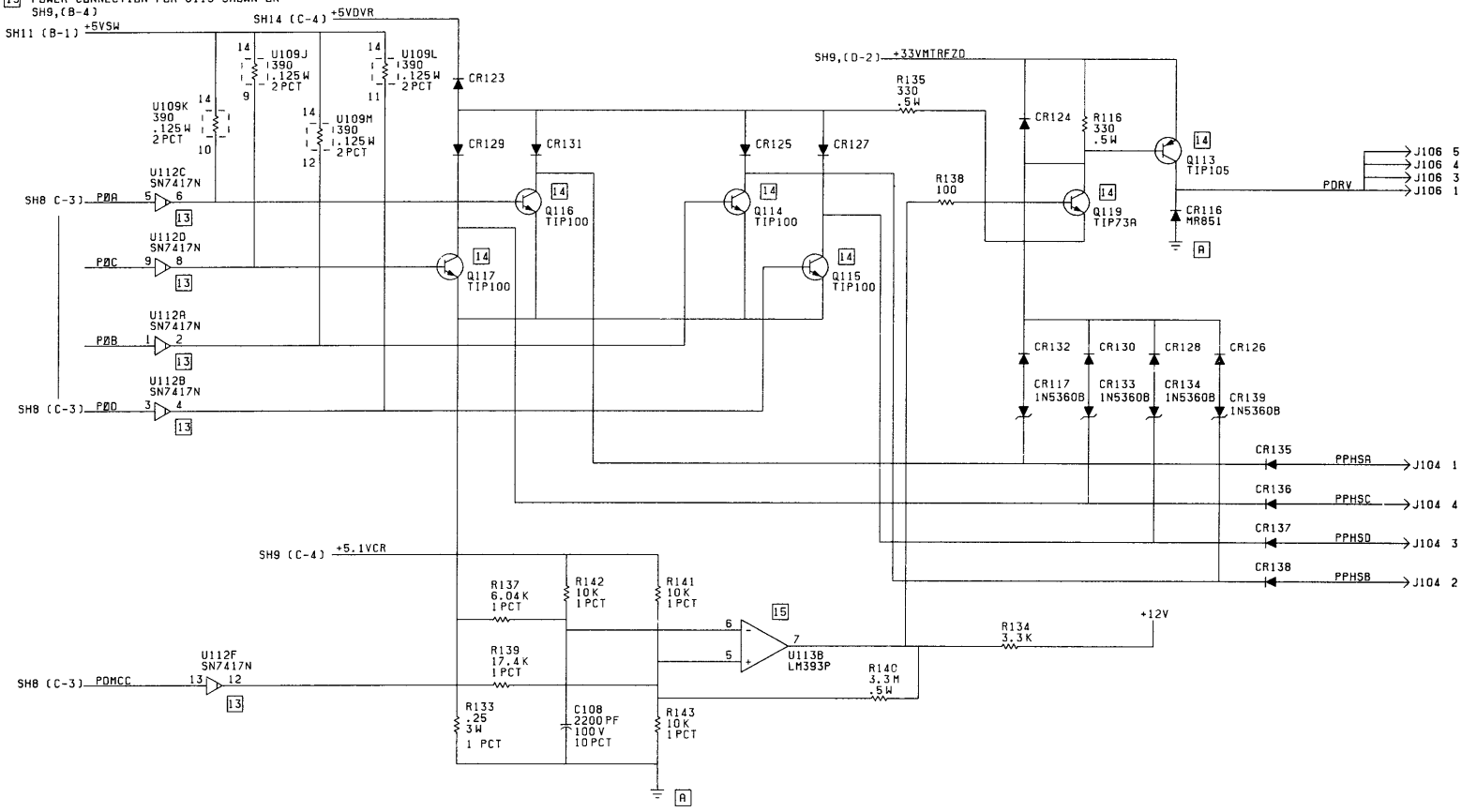

PAPER MOTOR DRIVE

NOTES:
 [16] DENOTES U104-14 IS CONNECTED TO +5VDR U104-7 IS CONNECTED TO [B]
 [B] DENOTES SECOND +33V MOTOR RETURN WHICH CONNECTS TO CENTRAL POINT GROUND AT POWER SUPPLY SECONDARY
 [17] DENOTES HEATSINKS ON U101, U102, AND U103 ARE CONNECTED TO E104

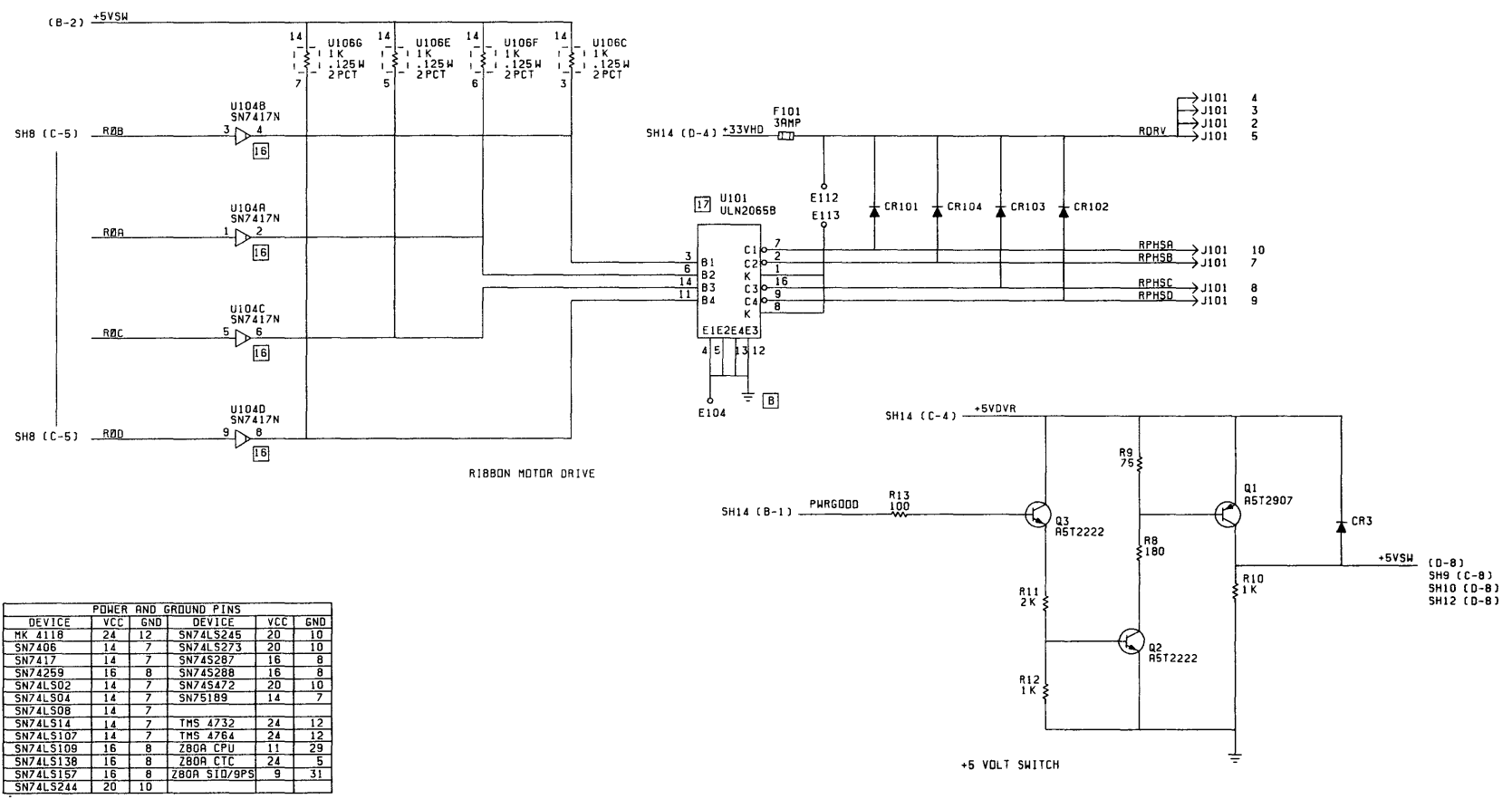

7-15

POWER AND GROUND PINS					
DEVICE	VCC	GND	DEVICE	VCC	GND
MK 4118	24	12	SN74LS245	20	10
SN7406	14	7	SN74LS273	20	10
SN7417	14	7	SN74S287	16	8
SN74259	16	8	SN74S288	16	8
SN74LS02	14	7	SN74S472	20	10
SN74LS04	14	7	SN75189	14	7
SN74LS08	14	7			
SN74LS14	14	7	TMS 4732	24	12
SN74LS107	14	7	TMS 4764	24	12
SN74LS109	16	8	Z80A CPU	11	29
SN74LS138	16	8	Z80A CTC	24	5
SN74LS157	16	8	Z80A SID/9PS	9	31
SN74LS244	20	10			

NOTES:

- 18 U104-14 AND U105-14 ARE CONNECTED TO +5VDVR, U104-7 AND U105-7 ARE CONNECTED TO B
- B DENOTES SECOND +33V MOTOR RETURN WHICH CONNECTS TO CENTRAL POINT GROUND AT POWER SUPPLY SECONDARY
- 19 HEATSINKS FOR Q101 AND Q102 ARE CONNECTED TO E102
- 20 NOTE 17 SH11

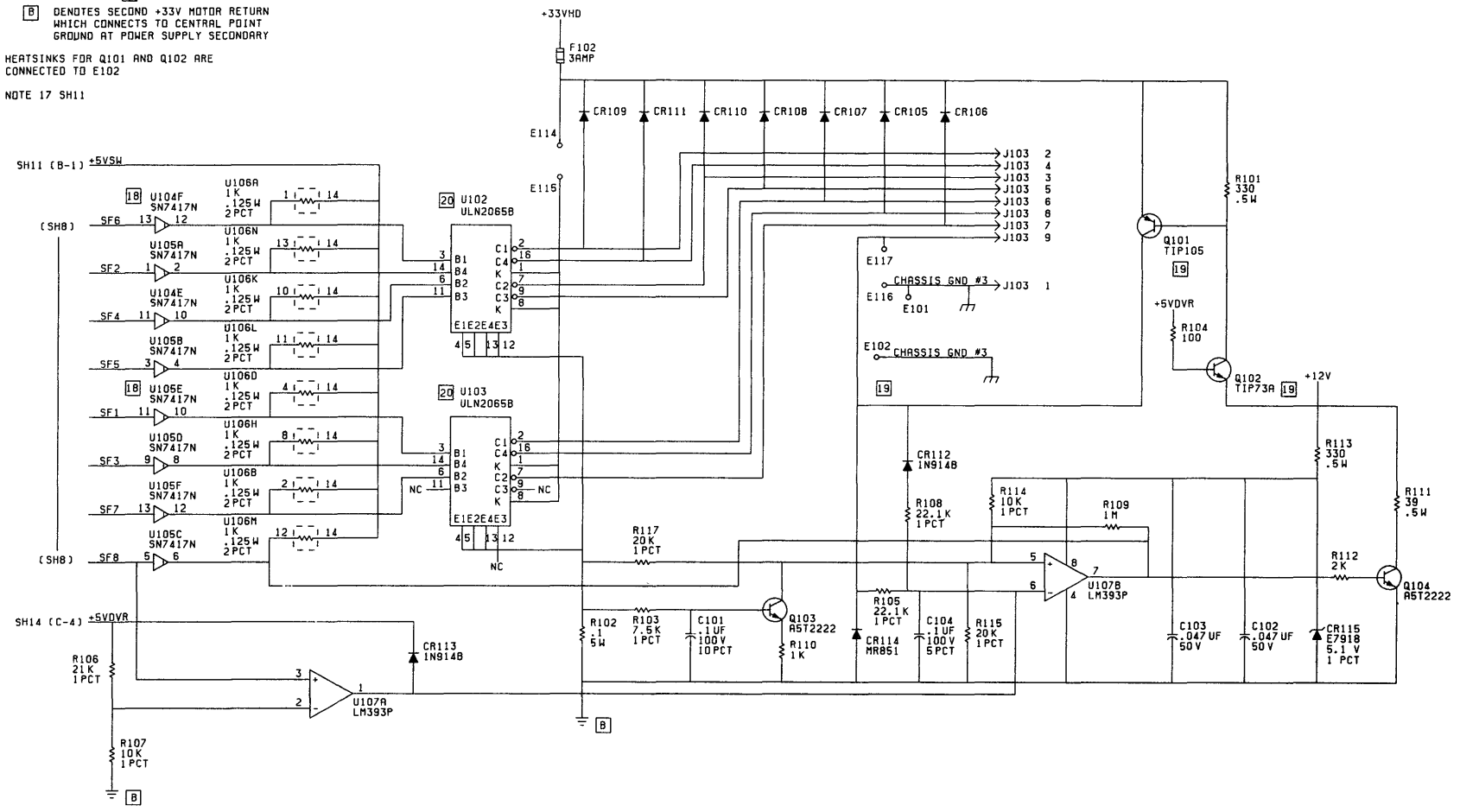

7-16

PRINTER DRIVE

REV	DESCRIPTION	REVISIONS	DATE	APPROVED
1				

- NOTES: UNLESS OTHERWISE SPECIFIED
1. RESISTORS ARE .25 W, 5 PCT
 2. R10 THROUGH R16 ARE 220 OHMS
 3. C2 THROUGH C6 ARE +80/-20 PCT
 4. CR72 IS "XMI1" LED
 5. CR74 IS "CARR" LED
 6. RESERVED FOR FUTURE EXPANSION

- NOTES: (CONTINUED)
7. USED ONLY ON ALTERNATE CHARACTER SET OPTION
 8. POWER AND GROUND PINS FOR DEVICE LM339N, +5V PIN 3, GND PIN 12
 9. USED FOR KEYBOARD IDENTIFICATION
 10. DIODES CR1 THRU CR15 ARE, IN914B

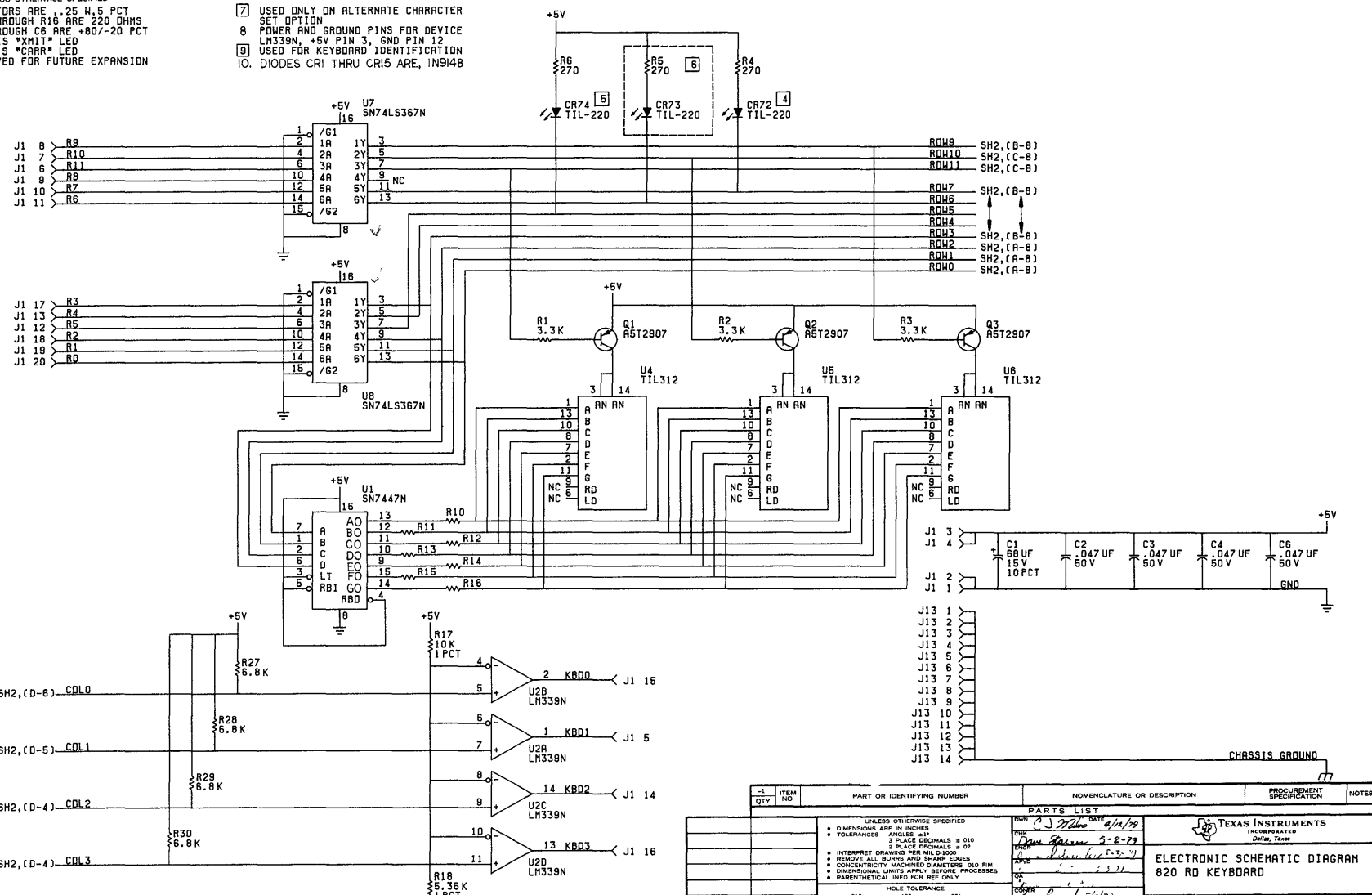

QTY	ITEM NO	PART OR IDENTIFYING NUMBER	NOMENCLATURE OR DESCRIPTION	PROCUREMENT SPECIFICATION	NOTES
			PARTS LIST		
			UNLESS OTHERWISE SPECIFIED		
			DIMENSIONS ARE IN INCHES		
			ANGLES 90°		
			TOLERANCES		
			3 PLACE DECIMALS ± 0.10		
			2 PLACE DECIMALS ± 0.2		
			1 PLACE DECIMAL ± 0.5		
			REMOVE ALL BURRS AND SHARP EDGES		
			CONCENTRICITY MACHINING DIMENSIONS ± 0.10 FIM		
			DIMENSIONAL LIMITS APPLY BEFORE PROCESSES		
			PARENTHEetical INFO FOR REF ONLY		
			HOLE TOLERANCE		
			D10 ± .004		
			D12 ± .004		
			D14 ± .004		
			D16 ± .004		
			D18 ± .004		
			D20 ± .004		
			D22 ± .004		
			D24 ± .004		
			D26 ± .004		
			D28 ± .004		
			D30 ± .004		
			D32 ± .004		
			D34 ± .004		
			D36 ± .004		
			D38 ± .004		
			D40 ± .004		
			D42 ± .004		
			D44 ± .004		
			D46 ± .004		
			D48 ± .004		
			D50 ± .004		
			D52 ± .004		
			D54 ± .004		
			D56 ± .004		
			D58 ± .004		
			D60 ± .004		
			D62 ± .004		
			D64 ± .004		
			D66 ± .004		
			D68 ± .004		
			D70 ± .004		
			D72 ± .004		
			D74 ± .004		
			D76 ± .004		
			D78 ± .004		
			D80 ± .004		
			D82 ± .004		
			D84 ± .004		
			D86 ± .004		
			D88 ± .004		
			D90 ± .004		
			D92 ± .004		
			D94 ± .004		
			D96 ± .004		
			D98 ± .004		
			D100 ± .004		
			D102 ± .004		
			D104 ± .004		
			D106 ± .004		
			D108 ± .004		
			D110 ± .004		
			D112 ± .004		
			D114 ± .004		
			D116 ± .004		
			D118 ± .004		
			D120 ± .004		
			D122 ± .004		
			D124 ± .004		
			D126 ± .004		
			D128 ± .004		
			D130 ± .004		
			D132 ± .004		
			D134 ± .004		
			D136 ± .004		
			D138 ± .004		
			D140 ± .004		
			D142 ± .004		
			D144 ± .004		
			D146 ± .004		
			D148 ± .004		
			D150 ± .004		
			D152 ± .004		
			D154 ± .004		
			D156 ± .004		
			D158 ± .004		
			D160 ± .004		
			D162 ± .004		
			D164 ± .004		
			D166 ± .004		
			D168 ± .004		
			D170 ± .004		
			D172 ± .004		
			D174 ± .004		
			D176 ± .004		
			D178 ± .004		
			D180 ± .004		
			D182 ± .004		
			D184 ± .004		
			D186 ± .004		
			D188 ± .004		
			D190 ± .004		
			D192 ± .004		
			D194 ± .004		
			D196 ± .004		
			D198 ± .004		
			D200 ± .004		

SEQ NO	IDENT	F SPEC	NO	ADDITIONAL CLASSIFICATION	NOTES

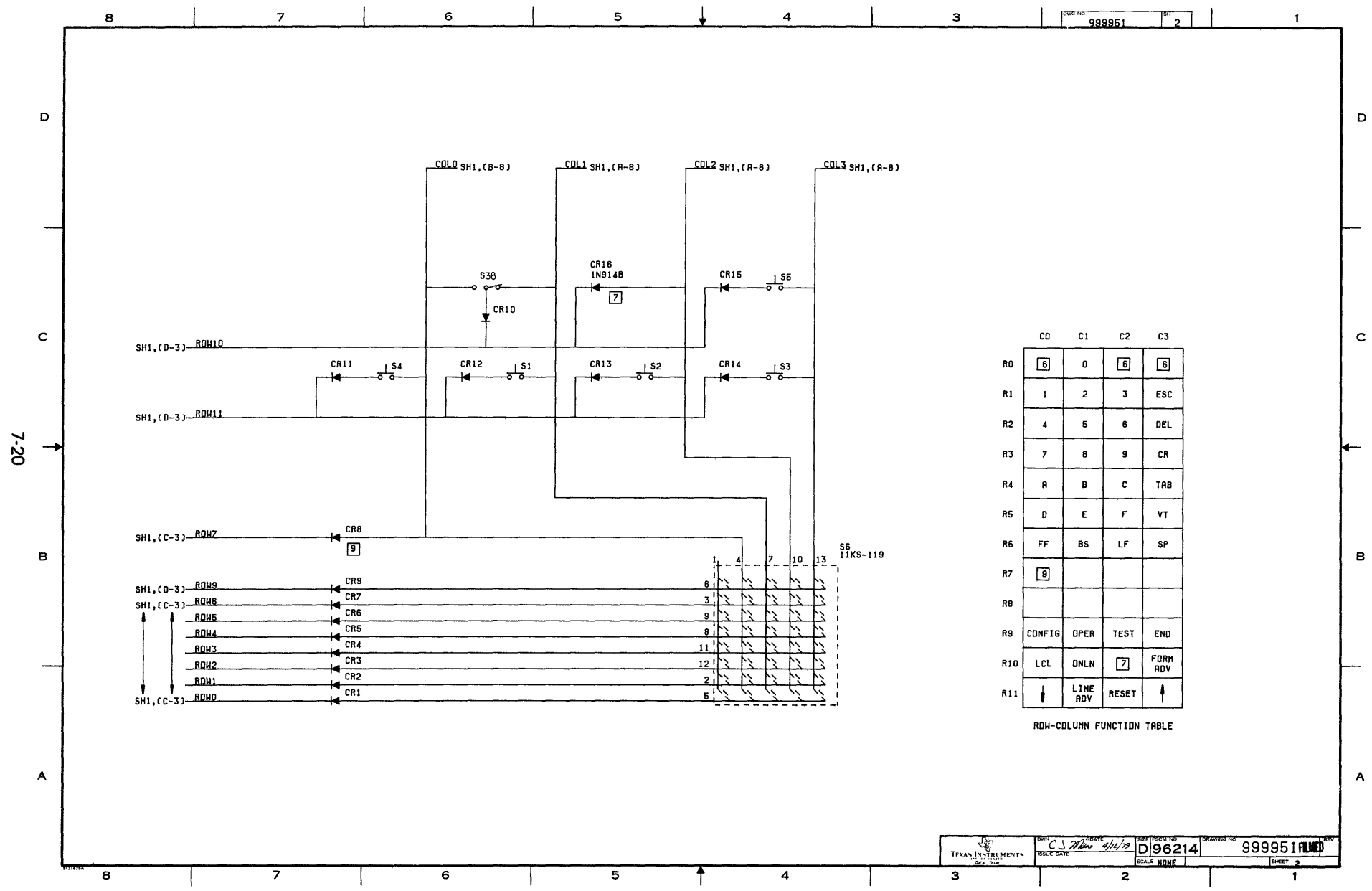

	C0	C1	C2	C3
R0	6	0	6	6
R1	1	2	3	ESC
R2	4	5	6	DEL
R3	7	8	9	CR
R4	A	B	C	TAB
R5	D	E	F	VT
R6	FF	BS	LF	SP
R7	9			
R8				
R9	CONFIG	OPER	TEST	END
R10	LCL	ONLN	7	FORM ADV
R11	↓	LINE ADV	RESET	↑

RDW-COLUMN FUNCTION TABLE

DWG NO. 2206530

REVOLUTIONS			
REV	DESCRIPTION	DATE	APPROVED
A	CN433855 R Revision 223-79	8-21-79	D Stamer

- NOTES UNLESS OTHERWISE SPECIFIED
1. CAPACITOR VALUES ARE MICROFARADS
 2. CAPACITORS ARE +80 -20 PERCENT
 3. RESISTOR VALUES ARE IN OHMS
 4. RESISTORS ARE .25W, 5%

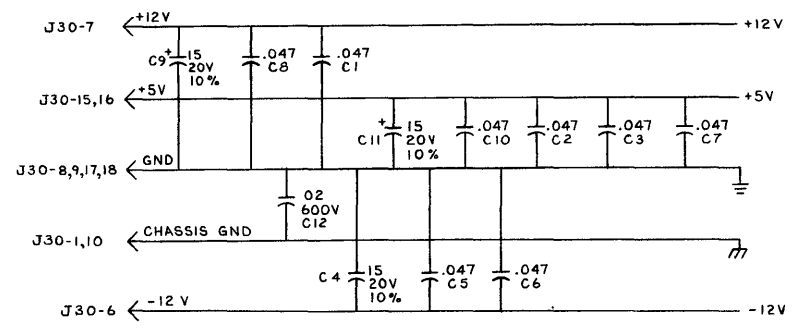

J30		J31	
16	+5	3	CF/109
15	+5	4	CE/125
7	+12	5	CC/107
6	-12	6	BA/103
18	SIGNAL GND	7	BB/104
17	SIGNAL GND	8	CH/111
9	SIGNAL GND	11	CA/105
8	SIGNAL GND	12	CB/106
1	CHASSIS GND	13	CD/108
10	CHASSIS GND	14	SCA/118
2	NC	15	SCF/119
3	NC	1	T×DCURIN
4	NC	10	T×DCURO
5	NC	18	R×DCURIN
11	NC	9	R×DCURO
12	NC	2	NC
13	NC	16	NC
14	NC	17	KEY

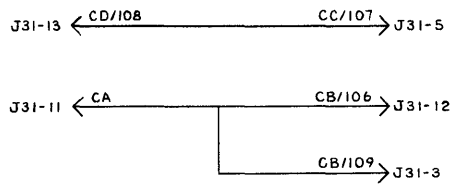

REV STATUS OF SHEETS	REV	A	A	
	SH	1	2	

-1	ITEM QTY	NO	PART OR IDENTIFYING NUMBER	NOMENCLATURE OR DESCRIPTION	PROCUREMENT SPECIFICATION	NOTES
PARTS LIST						
UNLESS OTHERWISE SPECIFIED			DATE: JBLancaster 2-28-79			
* DIMENSIONS ARE IN INCHES			* TOLERANCES - ANGLES ±1°			
* TOLERANCES - 3 PLACE DECIMALS = 010			* TOLERANCES - 2 PLACE DECIMALS = 02			
* INTERPRET DRAWING PER MIL-D-1000			* REMOVE ALL BURRS AND SHARP EDGES			
* CONCENTRICITY MACHINED DIAMETERS 010 FIM			* DIMENSIONAL LIMITS APPLY BEFORE PROCESSES			
* PARENTHEICAL INFO FOR REF ONLY			HOLE TOLERANCE			
			.013 THRU .004 251 = .006			
			.125 THRU .001 250 = .001			
			.501 + .008 THRU .001 1.000 + .012 THRU .001 2.000 - .001			
2206532		8740		APPLICATION		
NEXT ASSY		USED ON		DATE: 8-24-79		
				DRAWING NO. 2206530		
				SCALE: NONE		
				SHEET 1 OF 2		

SEQ NO	IDENT	F SPEC	NO	ADDITIONAL	NOTES
				CLASSIFICATION	

PROCESSES — FOR CORRELATION TO GOVT/IND SPECIFICATIONS SEE YI DRAWING 729467

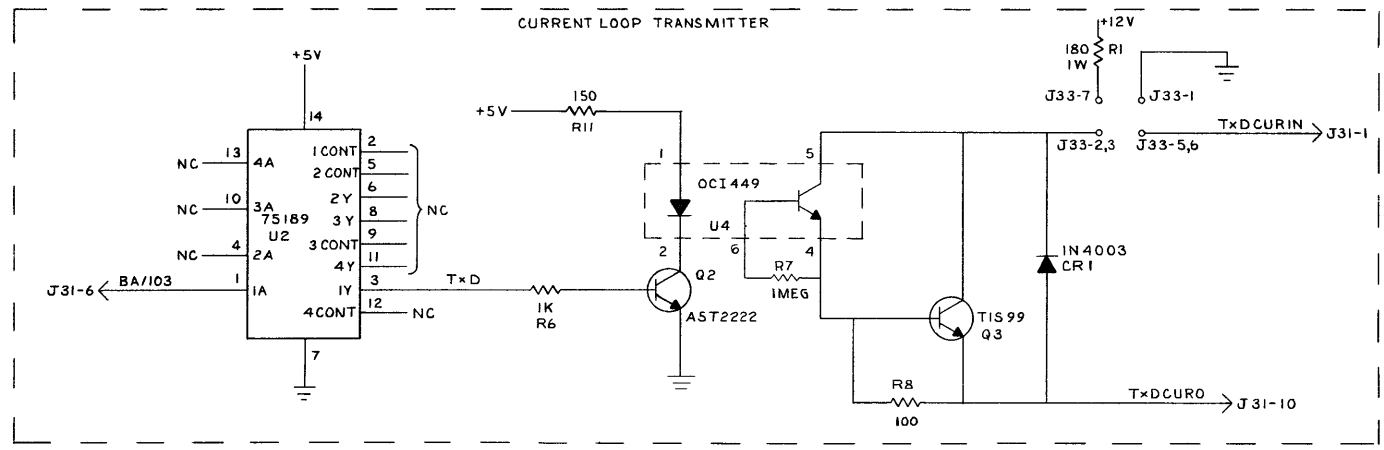
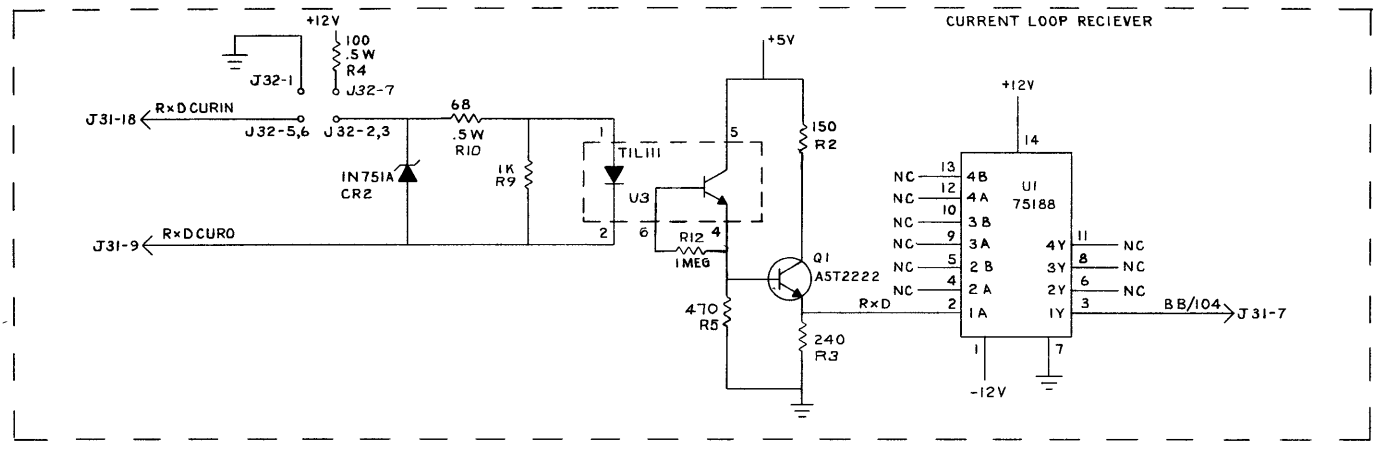

7-22

APPENDIX A

CHARACTER SET DOT MATRIX

Included in this appendix are the dot matrices of available character sets as printed by the Model 820 KSR and RO terminals. Ordering information for the various character sets is contained in Appendix C.

USASCII
Control Characters
European Characters
APL
Katakana

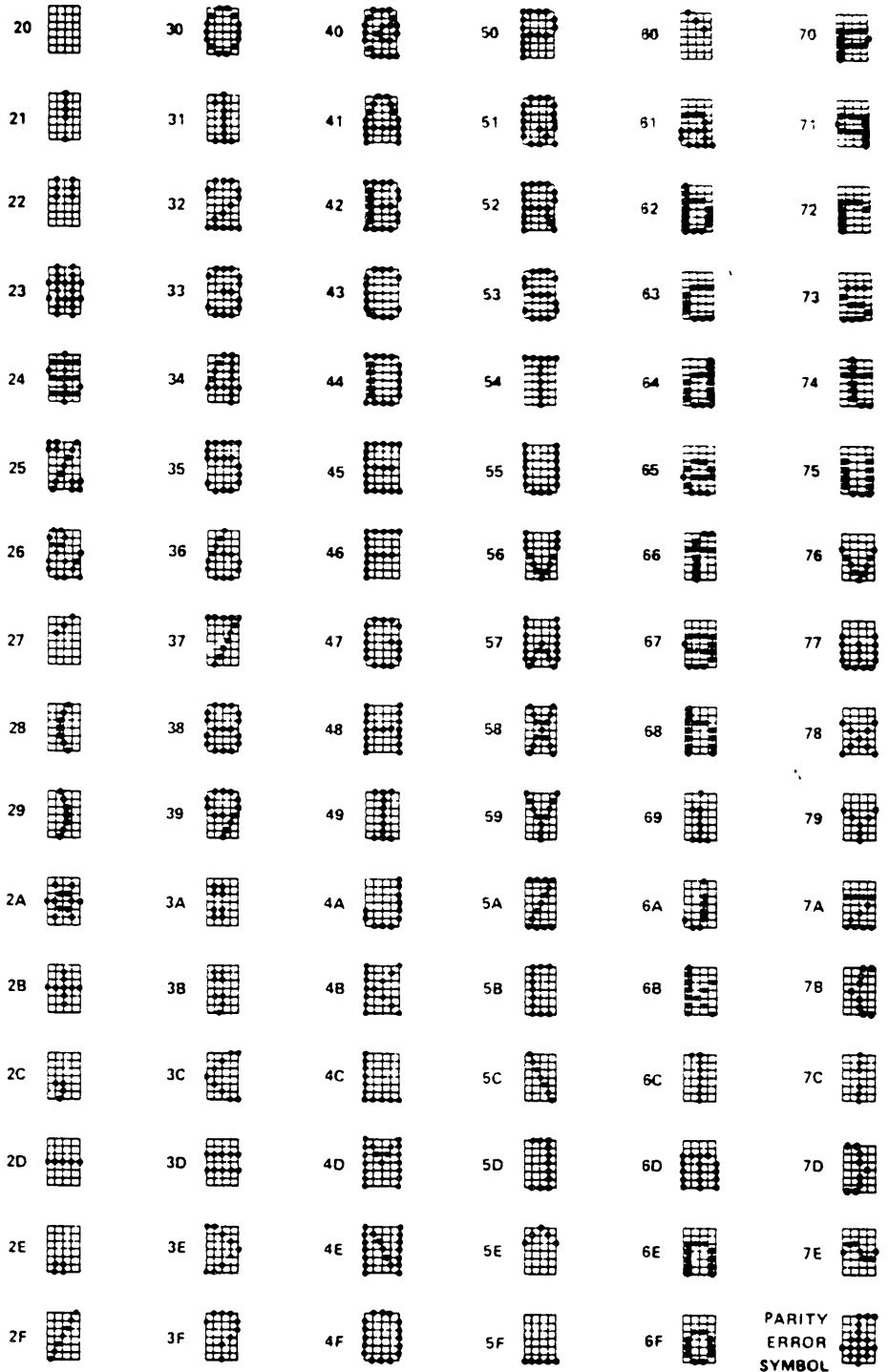

Figure A-1. Standard USASCII Character Font

00		NUL	20		DLE						
01		SOH	21		DC1						
02		STX	22		DC2						
03		ETX	23		DC3						
04		EOT	24		DC4						
05		ENQ	25		NAK						
06		ACK	26		SYN						
07		BEL	27		ETB						
08		BS	28		CAN						
09		HT	29		EM						
1A		LF	2A		SUB						
1B		VT	2B		ESC						
1C		FF	2C		FS						
1D		CR	2D		GS						
1E		SO	2E		RS						
1F		SI	2F		US						
					DEL						

Figure A-2. Control Character Font

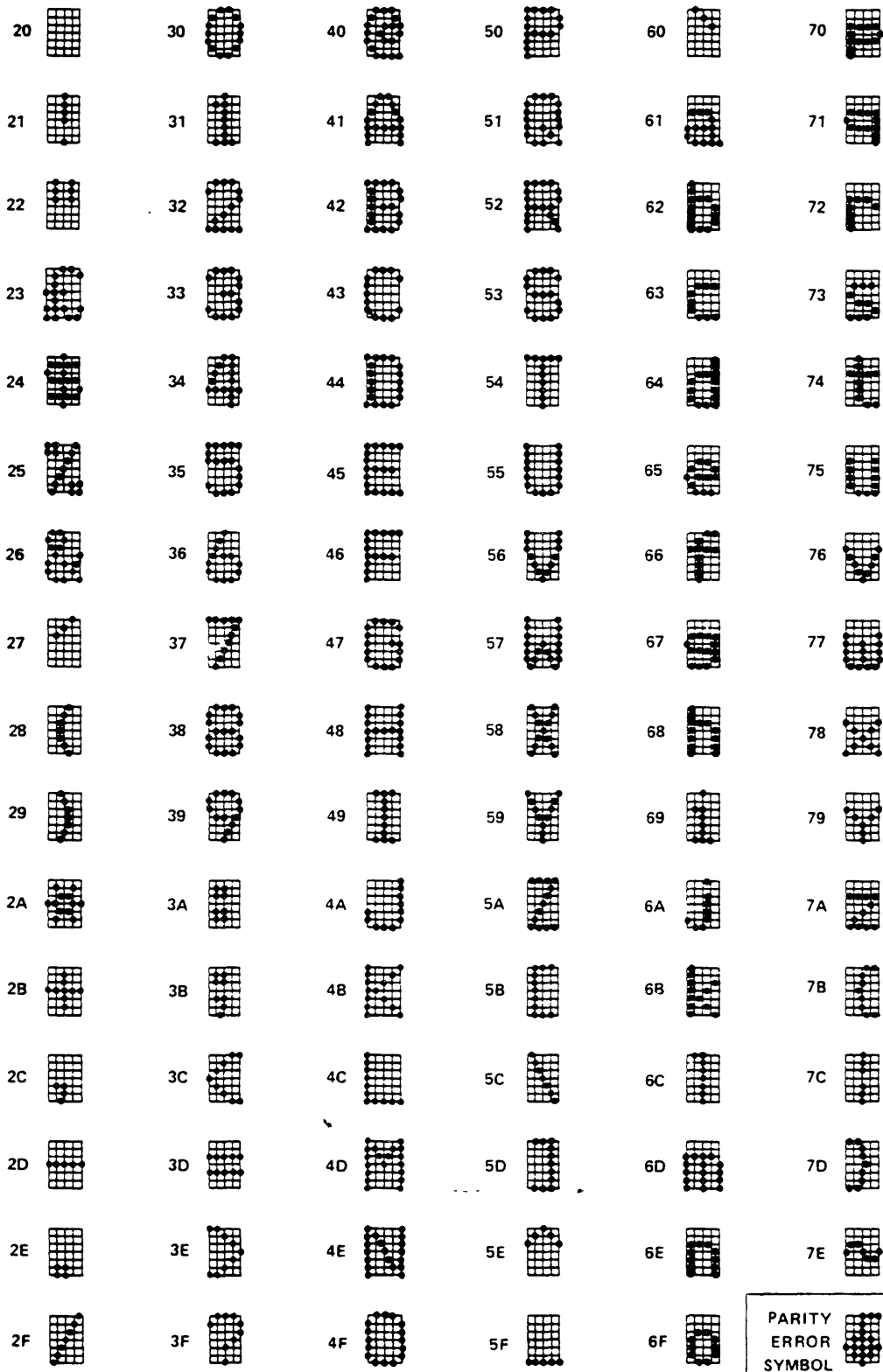

Figure A-3. United Kingdom Character Font

20		30		40		50		60		70	
21		31		41		51		61		71	
22		32		42		52		62		72	
23		33		43		53		63		73	
24		34		44		54		64		74	
25		35		45		55		65		75	
26		36		46		56		66		76	
27		37		47		57		67		77	
28		38		48		58		68		78	
29		39		49		59		69		79	
2A		3A		4A		5A		6A		7A	
2B		3B		4B		5B		6B		7B	
2C		3C		4C		5C		6C		7C	
2D		3D		4D		5D		6D		7D	
2E		3E		4E		5E		6E		7E	
2F		3F		4F		5F		6F			

PARITY
 ERROR
 SYMBOL

Figure A-4. German Character Font

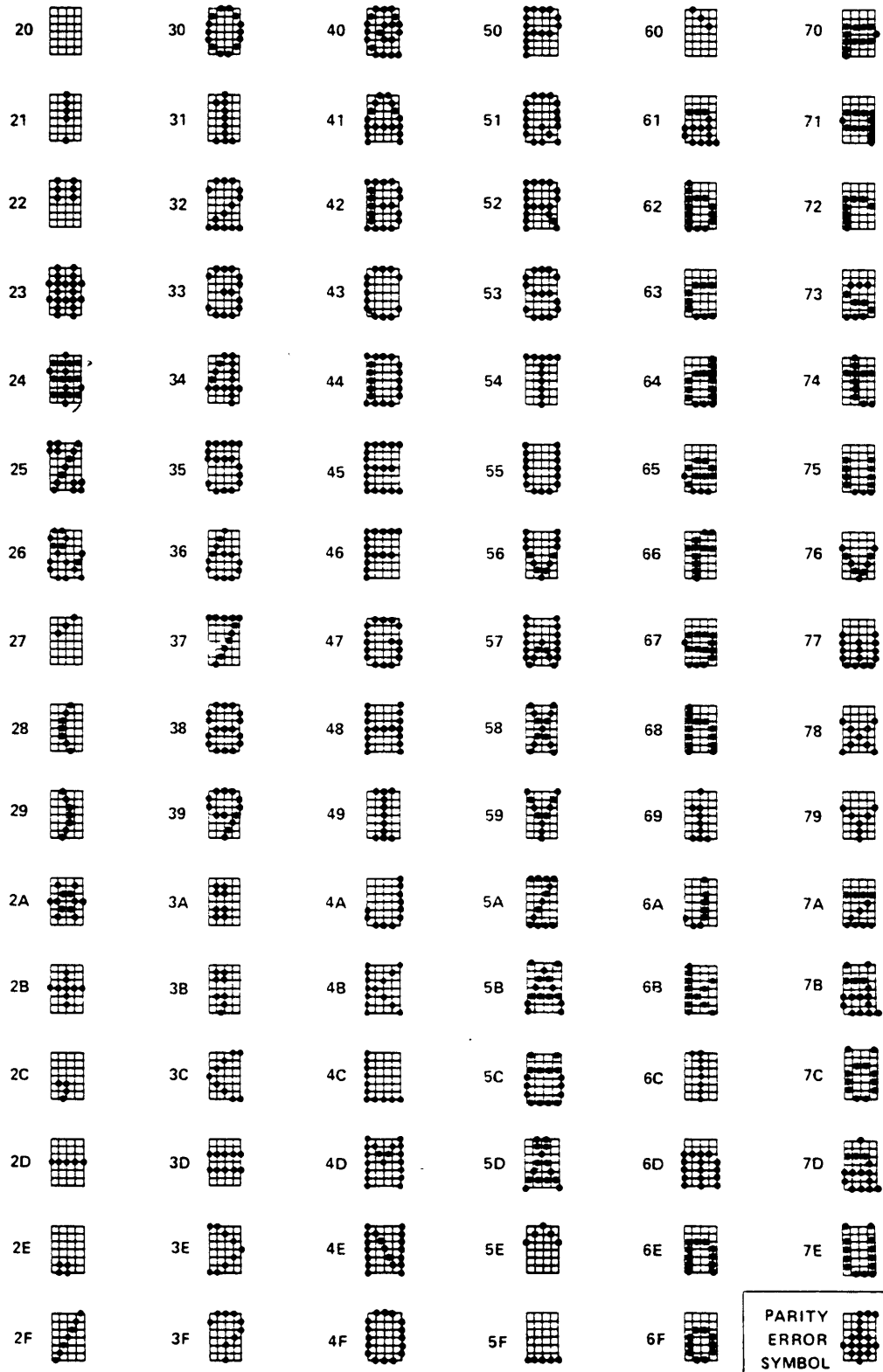

Figure A-5. Swedish/Finnish Character Font

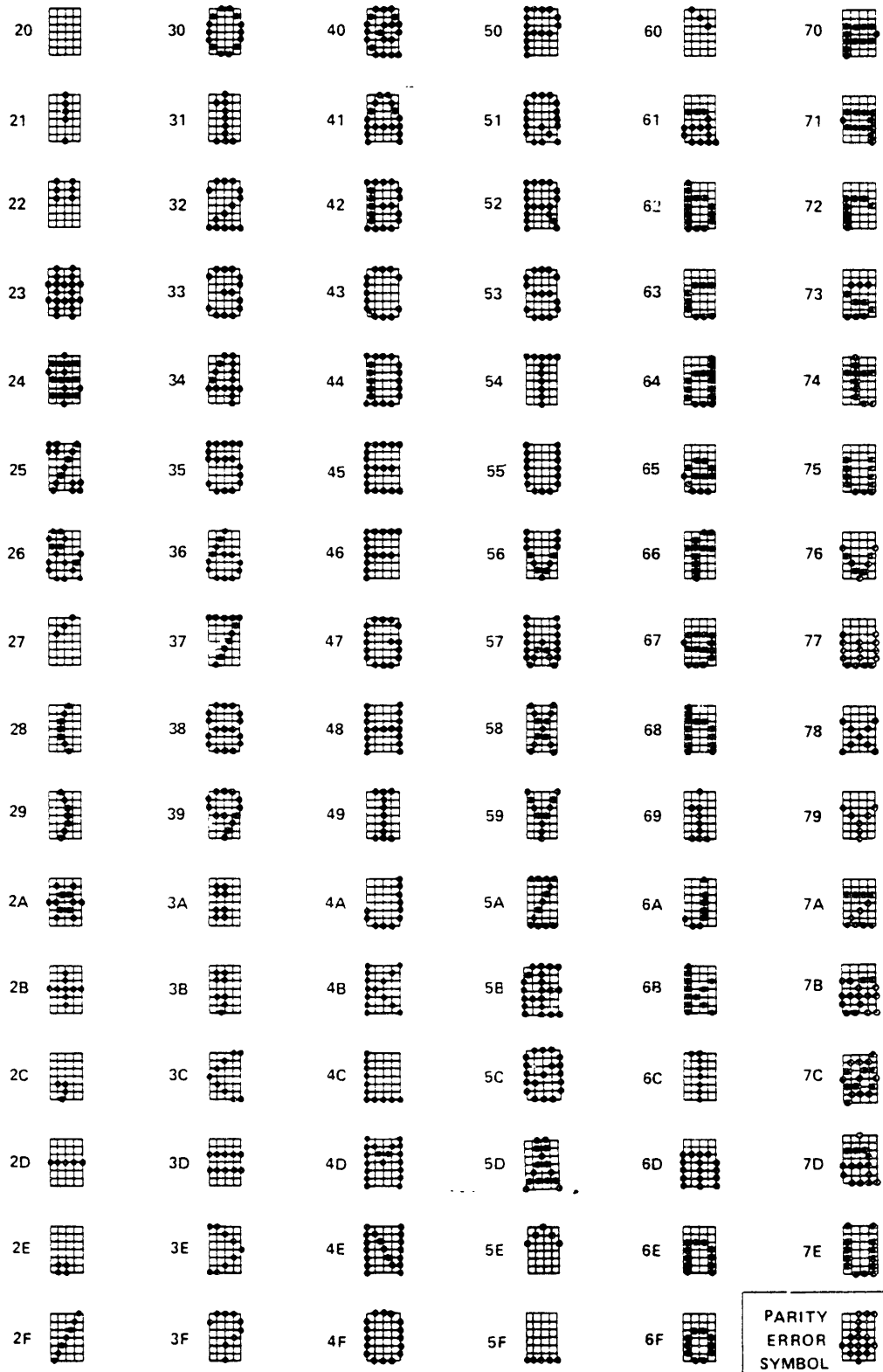

Figure A-6. Denmark/Norway Character Set

20		30		40		50		60		70	
21		31		41		51		61		71	
22		32		42		52		62		72	
23		33		43		53		63		73	
24		34		44		54		64		74	
25		35		45		55		65		75	
26		36		46		56		66		76	
27		37		47		57		67		77	
28		38		48		58		68		78	
29		39		49		59		69		79	
2A		3A		4A		5A		6A		7A	
2B		3B		4B		5B		6B		7B	
2C		3C		4C		5C		6C		7C	
2D		3D		4D		5D		6D		7D	
2E		3E		4E		5E		6E		7E	
2F		3F		4F		5F		6F		<div style="border: 1px solid black; padding: 2px;"> PARITY ERROR SYMBOL </div>	

Figure A-7. Standard Katakana Character Font

20		30		40		50		60		70	
	SPACE		0		NEGATIVE SIGN		STAR		DIAMOND		P
21					ALPHA						Q
	DIERESIS		1		DECODE				A		R
22					INTERSECTION				B		S
	R ₁ PARENTHESIS		2		FLOOR				C		T
23					EPSILON				D		U
	LESS THAN		3		UNDERSCORE				E		V
24					DELTA				F		W
	LESS THAN OR EQUAL		4		DEL				G		X
25					OMEGA				H		Y
	EQUAL		5		REVERSE IMPLICATION				I		Z
26					TAKE				J		LEFT BRACE
	GREATER THAN		6		IMPLICATION				K		LEFT TACK
27					LEFT PARENTHESIS				L		RIGHT TACK
	RIGHT BRACKET		7		LEFT BRACKET				M		RIGHT BRACE
28					QUOTE				N		DOLLAR SIGN
	OR		8		QUAD				O		
29					MODULUS						
	AND		9		RIGHT ARROW						
2A					GREATER THAN OR EQUAL						
	NOT EQUAL		SEMICOLON		MINUS						
2B											
	DIVIDE		BACKSLASH								
2C											
	COMMA										
2D											
	PLUS										
2E											
	PERIOD										
2F											
	SLASH										

Figure A-8. APL Character Font

APPENDIX B USASCII/APL CODES

The following codes are recognized by the Model 820 KSR.

ASCII/APL CHARACTER Set. The USASCII/APL character set is shown in Table B-1. Tables B-2 through B-6 list and define the optional character set codes.

Table B-1. USASCII/APL Character Set

CONTROL CODE		ASCII							APL						
ASCII or APL		0	1	2	3	4	5	6	7	2	3	4	5	6	7
ROW 0	NUL	DLE	SP	0	@	P	`	p	SPACE	0	-	.	◇	P	
1	SOH	DC1	!	1	A	Q	a	q	..		∞	?	A	Q	
2	STX	DC2	"	2	B	R	b	r)	2	↓	ρ	B	R	
3	ETX	DC3	#	3	C	S	c	s	<	3	∩	Γ	C	S	
4	EOT	DC4	\$	4	D	T	d	t	≡	4	L	~	D	T	
5	ENQ	NAK	%	5	E	U	e	u	=	5	ε	↓	E	U	
6	ACK	SYN	&	6	F	V	f	v	>	6	—	∪	F	V	
7	BEL	ETB	*	7	G	W	g	w]	7	∇	e	G	W	
8	BS	CAN	(8	H	X	h	x	V	8	Δ	∩	H	X	
9	HT	EM)	9	I	Y	i	y	∧	9		↑	I	Y	
A	LF	SUB	*	:	J	Z	j	z	#	(°	∪	J	Z	
B	VT	ESC	+	:	K	[k	{	÷		°	↑	K	{	
C	FF	FS	,	<	L	\	l	!	,	:	□	↑	L	→	
D	CR	GS	—	=	M]	m	}	+	x		↑	M	}	
E	SO	RS	.	>	N	^	n	~	.	:	T	≡	N	\$	
F	SI	US	/	?	O	—	o	DEL	/	\	O	-	O	DEL	

NOTE: Row and column designators are base 16 (hexadecimal) and a character is defined by a two-digit (Column/Row) hex number (e.g., ASCII M = 4D)

The ASCII control characters are generated on the Model 820 KSR by simultaneously depressing the CTRL key and the keys shown in Figure B-1. It is not possible for the operator to initiate any character transmissions from the Model 820 RO.

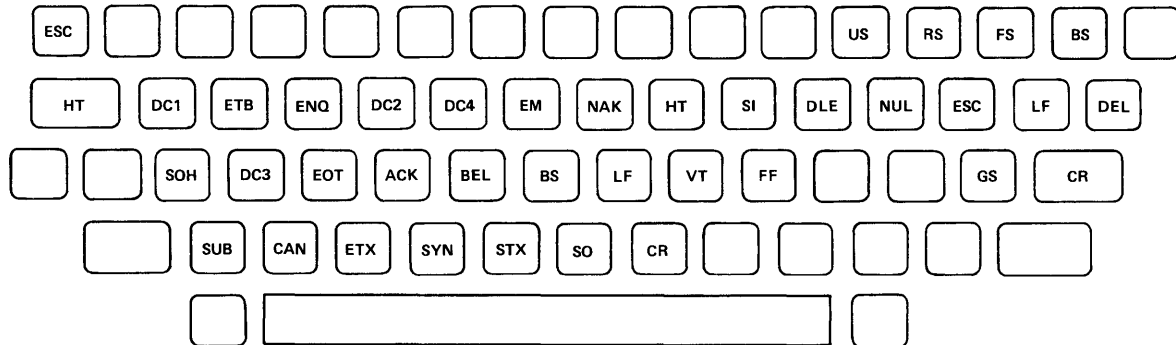

Figure B-1. Model 820 KSR Control Character Keyboard Layout

Table B-2. UKASCII Code Chart

COLUMN	0	1	2	3	4	5	6	7
ROW0	NUL	DLE	SP	0	@	P	.	p
1	SOH	DC1	!	1	A	Q	a	q
2	STX	DC2	"	2	B	R	b	r
3	ETX	DC3	£	3	C	S	c	s
4	EOT	DC4	\$	4	D	T	d	t
5	ENQ	NAK	%	5	E	U	e	u
6	ACK	SYN	&	6	F	V	f	v
7	BEL	ETB	'	7	G	W	g	w
8	BS	CAN	(8	H	X	h	x
9	HT	EM)	9	I	Y	i	y
A	LF	SUB	*	:	J	Z	j	z
B	VT	ESC	+	;	K	[k	{
C	FF	FS	'	<	L	\	l	!
D	CR	GS	-	=	M]	m	}
E	SO	RS	•	>	N	^	n	~
F	SI	US	/	?	O	-	o	DEL

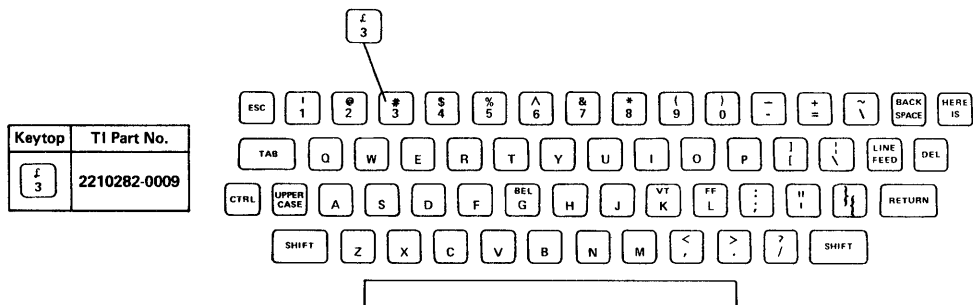

Figure B-2. English Keyboard (UKF), Model 820 KSR Only

Table B-3. German ASCII Code Chart

COLUMN	0	1	2		4	5	6	7
ROW 0	NUL	DLE	SP	0	@	P	.	p
1	SOH	DC1	!	1	A	Q	a	q
2	STX	DC2	"	2	B	R	b	r
3	ETX	DC3	#	3	C	S	c	s
4	EOT	DC4	\$	4	D	T	d	t
5	ENQ	NAK	%	5	E	U	e	u
6	ACK	SYN	&	6	F	V	f	v
7	BEL	ETB	'	7	G	W	g	w
8	BS	CAN	(8	H	X	h	x
9	HT	EM)	9	I	Y	i	y
A	LF	SUB	*	:	J	Z	j	z
B	VT	ESC	+	;	K	Ä	k	ä
C	FF	FS	,	<	L	Ö	l	ö
D	CR	GS	-	=	M	Ü	m	ü
E	SO	RS	•	>	N	^	n	β
F	SI	US	/	?	O	-	o	DEL

Keytop	T1 Part No.
ü	2210282-0007
ü	(Keyboard)
ü	2210282-0006
z	(Keyboard)
y	(Keyboard)
ö	2210282-0005
ä	2210282-0004
?	(Keyboard)

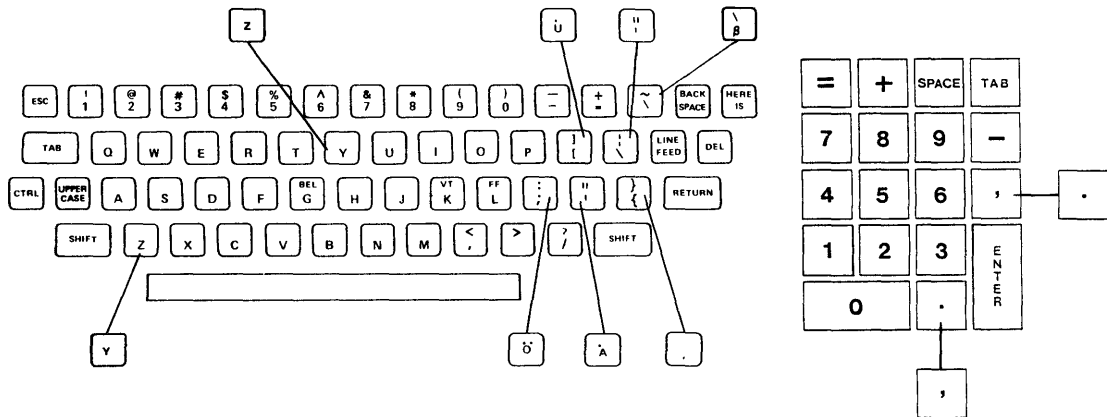

Figure B-3. Model 820 KSR German Keyboard Option

Table B-4. Swedish/Finnish ASCII Code Chart

COLUMN	0	1	2	3	4	5	6	7
ROW 0	NUL	DLE	SP	0	@	P	'	p
1	SOH	DC1	!	1	A	Q	a	q
2	STX	DC2	"	2	B	R	b	r
3	ETX	DC3	#	3	C	S	c	s
4	EOT	DC4	\$	4	D	T	d	t
5	ENQ	NAK	%	5	E	U	e	u
6	ACK	SYN	&	6	F	V	f	v
7	BEL	ETB	'	7	G	W	g	w
8	BS	CAN	(8	H	X	h	x
9	HT	EM)	9	I	Y	i	y
A	LF	SUB	*	:	J	Z	j	z
B	VT	ESC	+	;	K	Ä	k	ä
C	FF	FS	,	<	L	Ö	l	ö
D	CR	GS	-	=	M	Å	m	å
E	SO	RS	•	>	N	^	n	ü
F	SI	US	/	?	O	-	o	DEL

Keypop	TI Part No.
Ä	2210282-0002
Ë	(Keyboard)
Û	2210282-0001
Ö	2210282-0005
Å	2210282-0004
;	(Keyboard)

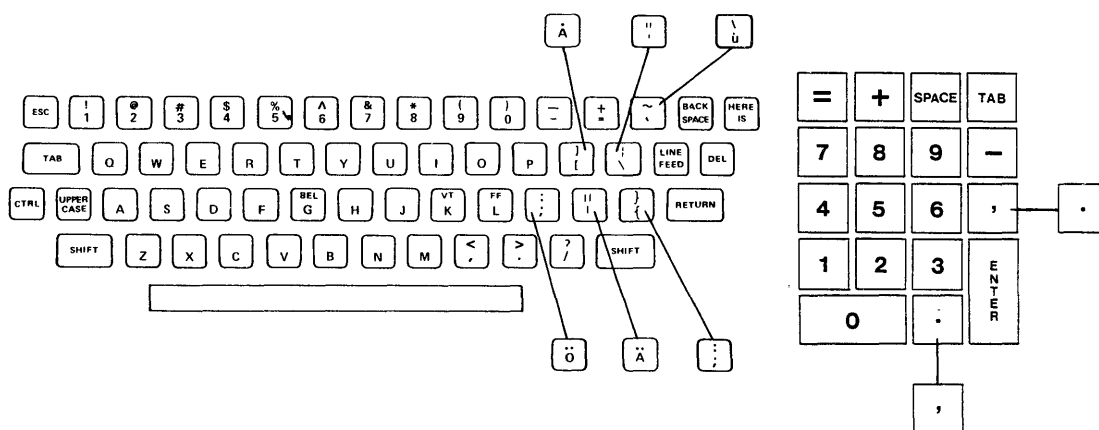

Figure B-4. Danish/Norwegian Code Chart

Table B-5. Danish/Norwegian Code Chart

COLUMN	0	1	2	3	4	5	6	7
ROW 0	NUL	DLE	SP	0	@	P	`	p
1	SOH	DC1	!	1	A	Q	a	q
2	STX	DC2	"	2	B	R	b	r
3	ETX	DC3	#	3	C	S	c	s
4	EOT	DC4	\$	4	D	T	d	t
5	ENQ	NAK	%	5	E	U	e	u
6	ACK	SYN	&	6	F	V	f	v
7	BEL	ETB	'	7	G	W	g	w
8	BS	CAN	(8	H	X	h	x
9	HT	EM)	9	I	Y	i	y
A	LF	SUB	*	:	J	Z	j	z
B	VT	ESC	+	;	K	Æ	k	æ
C	FF	FS	'	<	L	φ	l	φ
D	CR	GS	-	=	M	Å	m	å
E	SO	RS	•	>	N	^	n	~
F	SI	US	/	?	O	-	o	DEL

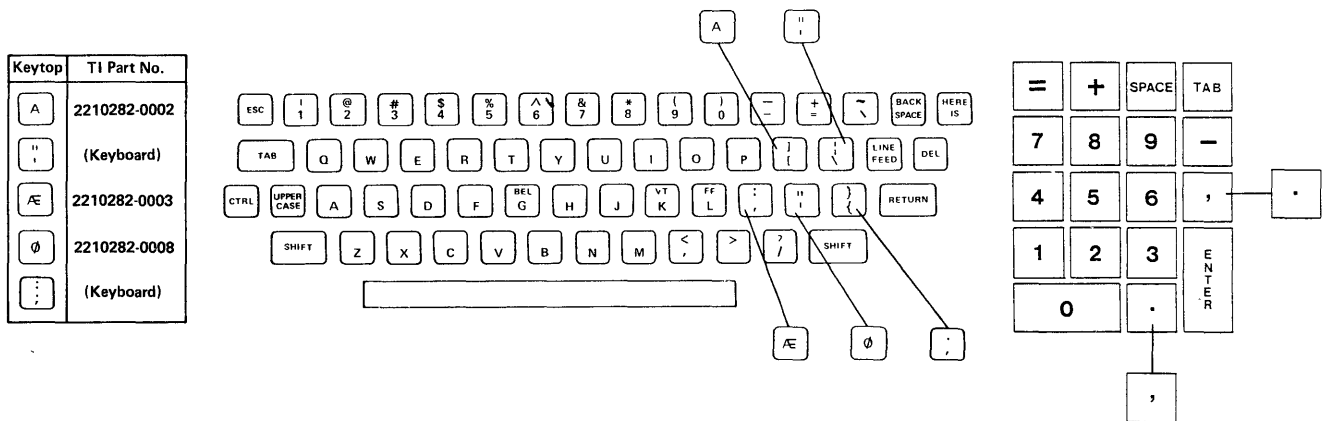

Figure B-5. Danish/Norwegian Keyboard (DNF) and Optional Numeric Pad, Model 820 KSR Only

Table B-6. Standard Katakana Code Chart

CONTROL FOR BOTH KANA & ASCII		U. S. ASCII MODE							KATAKANA MODE						
COLUMN	0	1	2	3	4	5	6	7	2	3	4	5	6	7	
ROW 0	NUL	DLE	SP	0	@	P	\	p	SPACE	-	タ TA	ミ MI	?	0	
1	SOH	DC1	!	1	A	Q	a	q	o	ア A	チ CHI	ム MU	!	1	
2	STX	DC2	"	2	B	R	b	r	「	イ I	ツ TSU	メ ME	"	2	
3	ETX	DC3	#	3	C	S	c	s	」	ウ U	テ TE	モ MO	#	3	
4	EOT	DC4	\$	4	D	T	d	t	\	エ E	ト TO	ヤ YA	\$	4	
5	ENQ	NAK	%	5	E	U	e	u	・	オ O	ナ NA	ユ YU	%	5	
6	ACK	SYN	&	6	F	V	f	v	ヲ O	カ KA	ニ NI	ヨ YO	&	6	
7	BEL	ETB	\	7	G	W	g	w	ア A	キ KI	ヌ NU	ラ RA	'	7	
8	BS	CAN	(8	H	X	h	x	イ I	ク KU	ネ NE	リ RI	(8	
9	HT	EM)	9	I	Y	i	y	ウ U	ケ KE	ノ NO	ル RU)	9	
A	LF	SUB	*	:	J	Z	j	z	ユ E	コ KO	ハ HA	レ RE	*	:	
B	VT	ESC	+	;	K	[k]	オ O	サ SA	ヒ HI	ロ RO	+	;	
C	FF	FS	,	<	L	¥ YEN	l	!	ヤ YA	シ SHI	フ FU	ワ WA	,	<	
D	CR	GS	-	=	M]	m	}	ユ YU	ス SU	ヘ HE	ン N	-	=	
E	SO	RS	.	>	N	^	n	~	ヨ YO	セ SE	ホ HO	"	.	~	
F	SI	US	/	?	O	-	o	DEL	ツ TSU	ソ SO	マ MA	°	/	DEL	

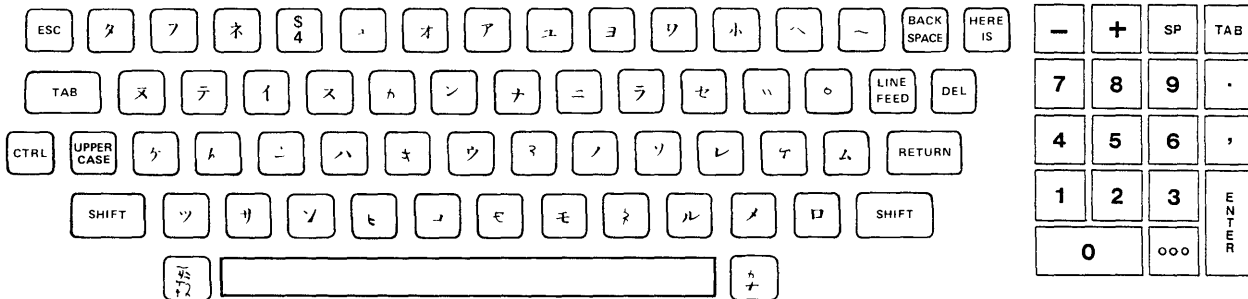

Figure B-6. Model 820 KSR Katakana Keyboard Option

Table B-7. USASCII/APL Character Set

CONTROL CODE		ASCII							APL						
COLUMN	ASCII or APL	2	3	4	5	6	7	2	3	4	5	6	7		
ROW 0	NUL DLE	SP 0	@ P	` p	SPACE 0	-	·	◇	P						
1	SOH DC1	! 1	A Q	a q	..		⊗	?	A Q						
2	STX DC2	" 2	B R	b r)	2	↓	ρ	B R						
3	ETX DC3	# 3	C S	c s	<	3	∩	Γ	C S						
4	EOT DC4	\$ 4	D T	d t	≤	4	L	~	D T						
5	ENQ NAK	% 5	E U	e u	≡	5	ε	↓	E U						
6	ACK SYN	& 6	F V	f v	>	6	—	U	F V						
7	BEL ETB	' 7	G W	g w]	7	∇	ε	G W						
8	BS CAN	(8	H X	h x	V	8	Δ	∩	H X						
9	HT EM) 9	I Y	i y	^	9		↑	I Y						
A	LF SUB	* :	J Z	j z	*	(·	∩	J Z						
B	VT ESC	+ ;	K [k {	÷	[·	↑	K {						
C	FF FS	· <	L \	l }	,	:	□	↑	L }						
D	CR GS	— =	M ^	m ~	+	x		↓	M ~						
E	SO RS	· >	N ^	n ~	·	:	T	M	N \$						
F	SI US	/ ?	O —	o DEL	/	\	O	-	O DEL						

NOTE: Row and column designators are base 16 (hexadecimal) and a character is defined by a two-digit (Column/Row) hex number (e.g., ASCII M=4D)

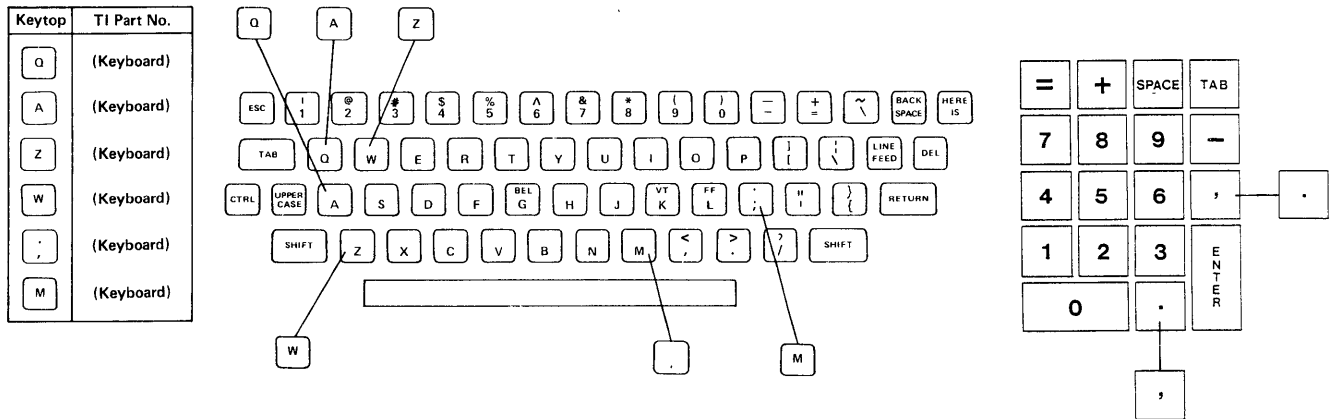

Figure B-7. French Keyboard (FRF) and Optional Numeric Pad, Model 820 KSR Only

APPENDIX C

MODEL 820 KSR/RO TERMINALS OPTIONS AND ACCESSORIES

Tables C1 and C2 list available options, accessories, and their part numbers and configuration abbreviations.

Table C-1. Model 820 KSR and RO Terminal Options

Description	TI Part Number	Configuration Abbreviation
Keyboard Assembly Options (One Only)		
Keyboard Assembly, Full ASCII	0999691-0101	KFS
Keyboard Assembly, Full ASCII, with Numeric Pad	0999691-0102	KFN
Keyboard Assembly, APL	0999691-0201	KAS
Keyboard Assembly, APL, with Numeric Pad	0999691-0202	KAN
Keyboard Assembly, European	0999691-0301	KES
Keyboard Assembly, European, with Numeric Pad	0999691-0302	KEN
Keyboard Assembly, Katakana	0999859-0001	KKS
Keyboard Assembly, Katakana, with Numeric Pad	0999859-0002	KKN
Control Panel Assembly, Model 820 RO	0999972-0001	KCP
Control Panel Assembly, Model 820 RO, APL	0999972-0002	KAP
Control Panel Assembly, Model 820 RO, Katakana	0999972-0003	KKP
PROM/ROM Options		
Kit, Device/Forms Control ROM	0999836-0001	MFG
Kit, Configuration PROM	2207630-0001	MDP/MPP
Kit, Protected ABM PROM	2207630-0002	MAP
Character Set Suboptions (One Only)		
Kit, Character Set, United Kingdom, ASCII (KSR)	2206525-0001	UKF
Kit, Character Set, Denmark/Norway, ASCII (KSR)	2206526-0001	DNF
Kit, Character Set, Sweden/Finland, ASCII (KSR)	2206527-0001	SFF
Kit, Character Set, France, ASCII (KSR)	2206528-0001	FRF
Kit, Character Set, Germany, ASCII (KSR)	2206529-0001	GRF
Kit, Character Set, United Kingdom, ASCII (RO)	2206525-0002	UKF
Kit, Character Set, Denmark/Norway, ASCII (RO)	2206526-0002	DNF
Kit, Character Set, Sweden/Finland, ASCII (RO)	2206527-0002	SFF
Kit, Character Set, France, ASCII (RO)	2206528-0002	FRF
Kit, Character Set, Germany, ASCII (RO)	2206529-0002	GRF
Stand Options		
Stand, w/o Top	0999841-0001	
Basket Kit, Paper-Stand	0999839-0001	
Interface Options		
Kit, Current-Loop Interface	0999734-0001	CTY
Keyboard Assembly Options (Field-Installed Only)		
Kit, Keyboard Assembly, Full ASCII	0999691-8101	KFS
Kit, Keyboard Assembly, Full ASCII, with Numeric Pad	0999691-8102	KFN
Kit, Keyboard Assembly, APL	0999691-8201	KAS
Kit, Keyboard Assembly, APL with Numeric Pad	0999691-8202	KAN
Kit, Keyboard Assembly, European	0999691-8301	KES
Kit Keyboard Assembly, European, with Numeric Pad	0999691-8302	KEN
Kit, Keyboard Assembly, Katakana	0999859-8001	KKS
Kit, Keyboard Assembly, Katakana with Numeric Pad	0999859-8002	KKN
Kit, Control Panel Assembly, Model 820 RO	0999972-8001	KCP
Kit, Control Panel Assembly, Model 820 RO, APL	0999972-8002	KAP
Kit, Control Panel Assembly, Model 820 RO, Katakana	0999972-8003	KKP

Table C-1. Model 820 KSR Terminal Options (Concluded)

Description	TI Part Number	Configuration Abbreviation
ROM/PROM Options (Field-Installed Only) Kit, Configuration PROM Kit, Protected ABM PROM Kit, Device/Forms Control ROM	2207630-8001 2207630-8002 0999836-8001	MDP/MPP MAP MFG
Printer Compressed Print Option (Field-Installed Only) Kit, Compressed Print	0999867-8001	
Character Set Suboptions (Field-Installed Only) Kit, Character Set, United Kingdom, Full ASCII (KSR) Kit, Character Set, Denmark/Norway, Full ASCII (KSR) Kit, Character Set, Sweden/Finland, Full ASCII (KSR) Kit, Character Set, France, Full ASCII (KSR) Kit, Character Set, Germany, Full ASCII (KSR) Kit, Character Set, United Kingdom, ASCII (RO) Kit, Character Set, Denmark/Norway, ASCII (RO) Kit, Character Set, Sweden/Finland, ASCII (RO) Kit, Character Set, France, ASCII (RO) Kit, Character Set, Germany, ASCII (RO)	2206525-8001 2206526-8001 2206527-8001 2206528-8001 2206529-8001 2206525-8002 2206526-8002 2206527-8002 2206528-8002 2206529-8002	UKF DNF SFF FRF GRF UKF DNF SFF FRF GRF
Interface Options (Field-Installed Only) Kit, Current-Loop Interface	0999734-8001	CTY

Table C-2. Model 820 Terminal Accessories

Base Description	Part Number
Basket, Kit, Paper	0999838-0001
Ribbon, Black Nylon Matrix 60 yd. (single)	0996704-0001
Ribbon, Black Nylon Matrix 60 yd. (6 pack)	0996704-0002
Ribbon, Black Nylon Matrix 40 yd. (single)	0996241-0001
Ribbon, Black Nylon Matrix 40 yd. (6 pack)	0996241-0002
Manual, Maintenance	2206552-9701
Manual, Operator's (Model 820 KSR)	2208225-9701
Manual, Operator's (Model 820 RO)	2206553-9701
Kit, Acoustic Enhancement	0999886-0001
Window, Terminal	0999713-0001
Accessory Cables	
Cable Assembly, EIA Extension	0993211-0001
Cable Assembly, Data Terminal	0993210-0001
Cable Assembly, 990 Computer	2262093-0001
Cable Assembly, Asynch/Synch EIA Data Set	2207634-0001
Cord Set, Power, Domestic	0996289-0001
Cord Set, Power, Western Europe	0996290-0001
Cord Set, Power, w/o Connector	0996348-0001
Cable Assembly, 202/212	0993205-0001

APPENDIX D

OMNI 800 MODEL 820 PRINTER

RIBBON AND PAPER RECOMMENDATIONS

RIBBON

The Omni 800* Model 820 Terminal is furnished with a black nylon matrix, impact printer ribbon wound on dual spools. Replacement ribbons may be purchased from Texas Instruments in packs of six under part number 0996704-0002.

To prolong the life of your printhead, use only the above print ribbon or an equivalent available from Addressograph Multigraph Corporation under part number 116-2800-163.

PAPER

The Model 820 Terminal will accept standard, dual-sprocket-punched, continuous, business form paper in any width from 3 to 15 inches (76.2 to 38.1 mm).

Multiple-part business forms, one original and up to five copies, can be printed on paper with the following weight specifications:

- | | |
|---------------------|---|
| Single Part Forms | — 15 to 20 pounds |
| Multiple Part Forms | — Original: 12 to 15 pounds
Copies: 9 to 12 pounds
Last Copy: 15 pounds |
| Carbon Paper | — 7.5 pounds with medium hardness. |

NOTE

Total form thickness should not exceed 0.021 inch (0.53 mm).

*Trademark of Texas Instruments Incorporated.

APPENDIX E

INSTALLATION OF OPTIONAL KITS

This appendix contains installation instructions for the following accessory and option kits:

- Terminal Stand Kit (999841-0001)
- Acoustic Enhancement Kit (999886-0001)
- Terminal Paper Basket (999938-0001)
- Terminal Stand Paper Basket (999839-0001)
- Device/Forms Control Kit (999836-0001)
- Configuration/Protected ABM PROM Kit (2207630-0001)
- Current-Loop Option Kit (999734-0001)

INSTALLATION INSTRUCTIONS

Omni 800 TERMINAL STAND KIT

Kit Part Number 0999841-0001

1. GENERAL

The *Omni 800** Terminal Stand kit consists of a specially designed table and all necessary hardware for attachment of a Texas Instruments Model 810 or Model 820 to the stand.

2. INSTALLATION INSTRUCTIONS

The following instructions explain how to attach an *Omni 800* printer. The procedure varies from the Model 810 to the Model 820, so choose the appropriate instruction for your model.

2.1 MODEL 810 PRINTER INSTALLATION

- a. Disconnect the ac power cable and the communications cable (if installed).
- b. Install levelling screws in each corner of the legs as shown in Figure 1.
- c. Install the modesty panel with four 6-32 screws and lockwashers as shown, and be sure the lockwashers are next to the screw heads.
- d. Install the spacer panel and ring lug end of the ground cable with four 6-32 screws and lockwashers as shown. Be sure the lockwashers are next to the screw heads and the ground cable is at the rear of the left leg.
- e. Mount the Model 810 printer on the stand with four 10-12 self-tapping screws as shown in the figure.
- f. Remove the right rear screw and lockwasher from the printer rear paper chute.
- g. Attach the ground cable lug to the printer with the screw and lockwasher removed in step f. Be sure the lockwasher is installed between the paper chute and the ground cable lug.
- h. Place the printer and stand in the desired operating location and adjust the leg levelers as required to level the printer.

- i. Reconnect the ac power cable and communications cable as required.

2.2 MODEL 820 PRINTER INSTALLATION

- a. Disconnect the ac power cable and the communications cable (if installed).
- b. Install levelling screws in each corner of the legs as shown in Figure 2.
- c. Install the modesty panel with four 6-32 screws and lockwashers as shown, and be sure the lockwashers are next to the screwheads.
- d. Install the spacer panel with four 6-32 screws and lockwashers as shown, and be sure the lockwashers are next to the screwheads.
- e. Mount the Model 820 printer on the stand with four 10-32 UNC \times 1¼ panhead screws and No. 10 external tooth washers.



Do not substitute longer screws; damage to the machine may result.

- f. Place the printer and stand in the desired operating location and adjust the leg levelers as required to level the printer.
- g. Reconnect the ac power cable and communications cable as required.

*Trademark of Texas Instruments Incorporated

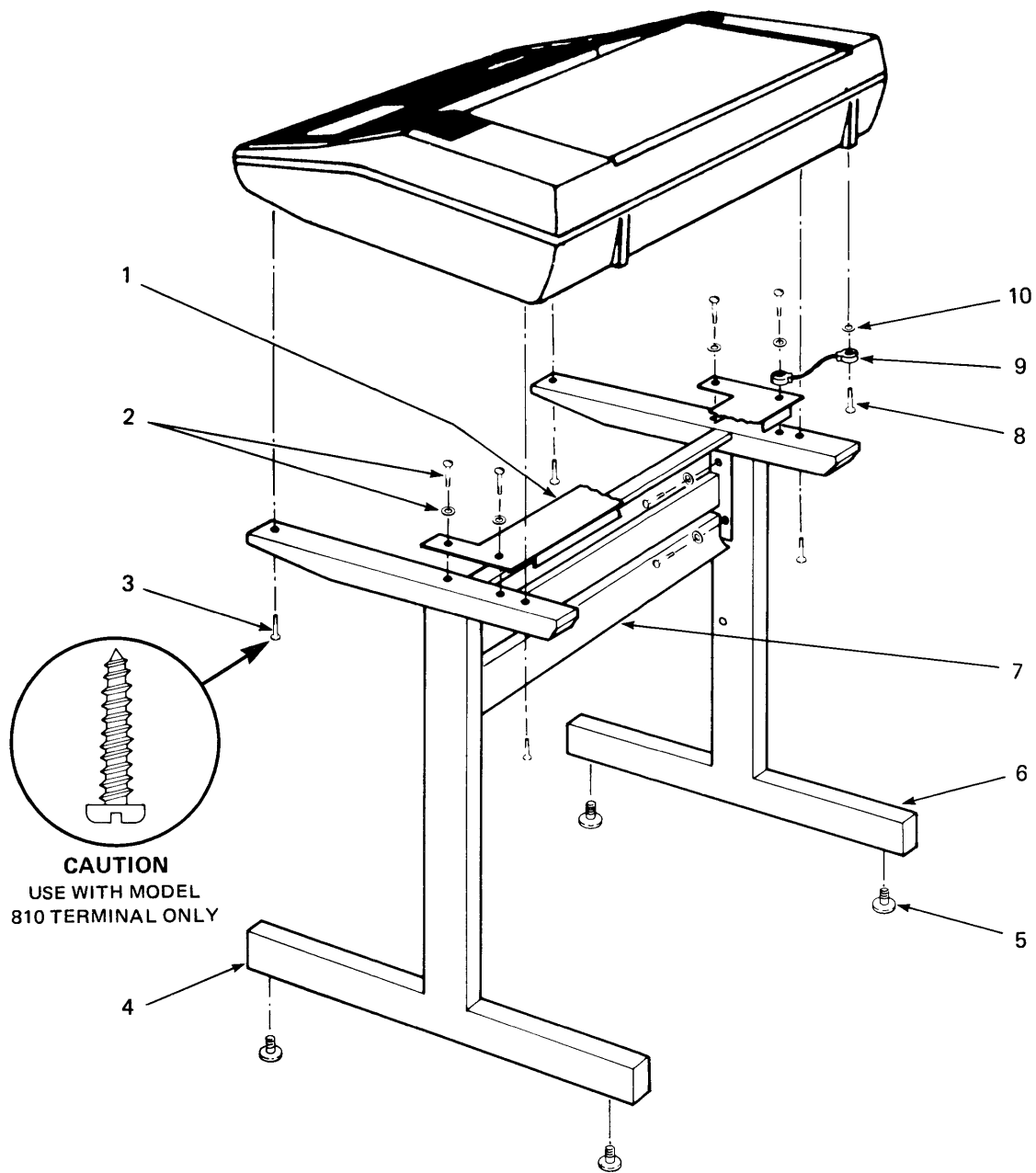

- | | |
|---|----------------------------|
| 1. Spacer panel | 6. Left leg |
| 2. 6-32 x ½ self tapping screw and external tooth washer (8 places) | 7. Modesty panel |
| 3. 10-12 self tapping x 1 lg screw (4 places) | 8. Existing printer screw* |
| 4. Right leg | 9. Ground cable |
| 5. Leveler (4 places) | 10. External tooth washer |
- * Not supplied in Kit

Figure 1. Model 810 Terminal Stand Kit

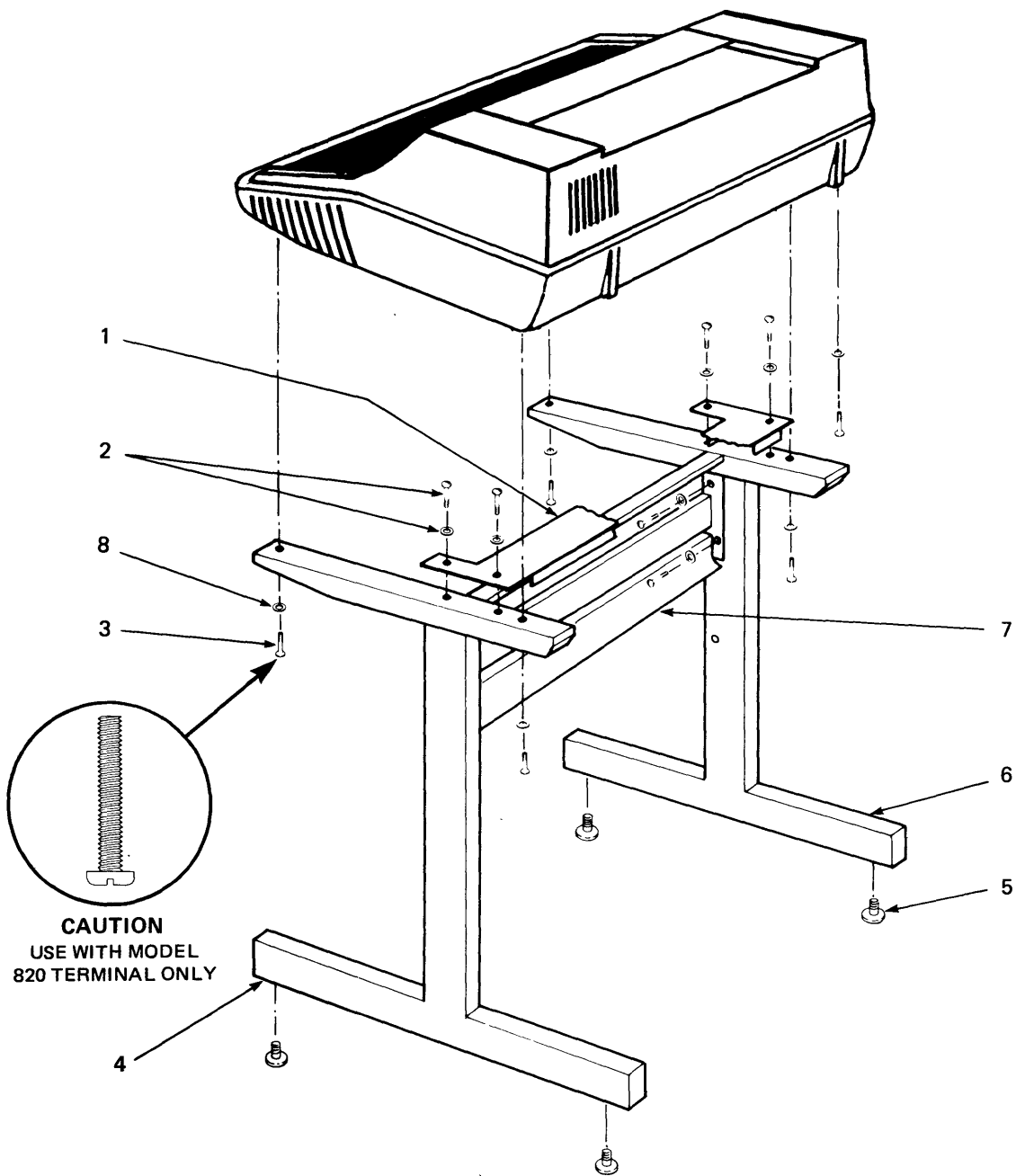

- | | |
|---|--|
| 1. Spacer panel | 5. Leveler (4 places) |
| 2. 6-32 x 1/2 self tapping screw and external tooth washer (8 places) | 6. Left leg |
| 3. 10-32 UNC x 1/4 panhead screw (4 places) | 7. Modesty panel |
| 4. Right leg | 8. No. 10 external tooth washer (4 places) |

Figure 2. Model 820 Terminal Stand Kit



INSTALLATION INSTRUCTIONS
OMNI 800* Acoustic Enhancement Kit
for the
Model 820 Data Terminal
Part Number 0999886-0001

1. PARTS FURNISHED

The Model 820 Acoustic Enhancement Kit consists of three major assemblies:

- **Insulator Pad** — is placed under the terminal; the insulator pad adheres to the terminal base by its self-adhesive coating.
- **Air Exhaust Cover** — is attached over the 12 air exhaust slots at the rear of the terminal using three slotted hex screws (see Figure 1).

NOTE

Some versions of the air exhaust cover simply snap into position.

- **Damper** — to be attached atop the terminal using four screws, two large washers, and two small washers (see Figure 1).

2. INSTALLATION

Disconnect the communications cable and the power cord from the rear of the terminal to prevent possible electrical shock and proceed with the following steps in the order presented.

2.1 INSULATOR PAD

If the terminal is secured to an *OMNI 800* accessory stand or to a table, first remove any fasteners so that the terminal may be lifted freely.

- a. Lift the terminal cover and remove the two ribbon spools and the ribbon and set aside. Close the terminal cover.

NOTE

Seek the help of another person, if available, to complete some of the following steps.

- b. With the aid of another person, carefully turn the terminal upside down on a softly padded surface (use a sheet of sponge rubber, a blanket, or some other soft mat to prevent marring the terminal cover).
- c. Remove the protective paper from the insulator pad and attach the adhesive side of the pad to the terminal base. Take care to align the slot in the pad over the paper feed slot in the terminal base. Press the pad to cause it to adhere to the base.

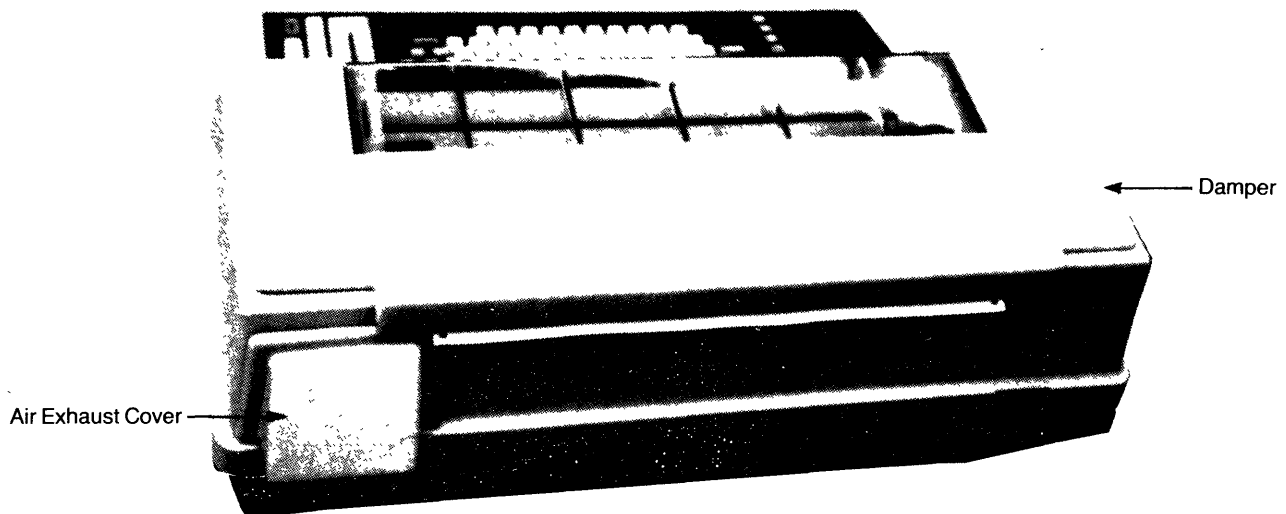

**Figure 1. Acoustic Enhancement Kit
Major Components**

*Trademark of Texas Instruments Incorporated

- d. With the aid of another person, carefully turn the terminal right side up, place the terminal on a large work surface, and proceed to the *air exhaust cover* installation instructions below.

2.2 AIR EXHAUST COVER

The air exhaust cover is designed to direct noise and cooling air down and away from the operator.

NOTE

The air exhaust cover is supplied in two versions: One version attaches to the rear air outlet using three screws; the other version simply snaps into place.

- a. If your air exhaust cover has three “hooks” extending from the inside, simply hook the bottom two hooks into the far right and far left air slots, and press the top of the air exhaust cover inward to snap the single top hook into place.

OR

- b. If the inside of your air exhaust cover has three posts with screw holes in their centers, proceed as follows:

- (1) Lift up the terminal cover until the plastic stay at the inside right rear locks, holding the cover about 45 degrees from horizontal.
- (2) Holding the terminal cover in one hand, grasp the top of the plastic cover stay (see Figure 2) with the other hand and move the stay to the right until it clears the mounting pin.
- (3) The terminal cover now can be swung back on its hinges to rest, upside down, on a table top or other surface.
- (4) Lift the terminal cover so that it is approximately perpendicular to the table. Ask someone to hold the terminal cover in this position, or prop it with several books, blocks, etc.
- (5) Place the air exhaust cover over the outside of the 12 air vents in the right rear corner of the terminal cover. Hold in place with one hand while *starting* the three screws through the air vent slots into the three posts inside the air exhaust cover. *DO NOT tighten the three screws yet.*

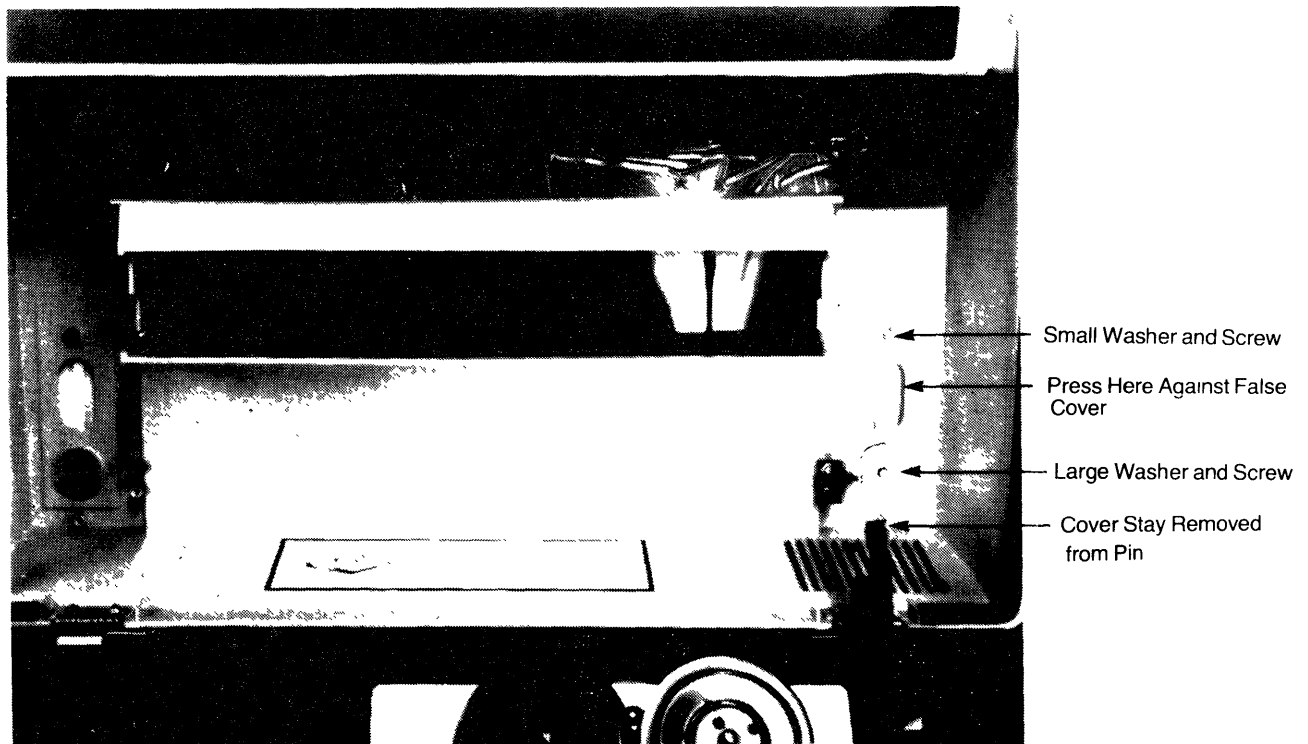

Figure 2. View Inside Terminal Cover

- (6) Lower the terminal cover toward its normal closed position so that you may view the placement of the air exhaust cover; the top of the air exhaust cover should be aligned with the surface of the ribbed, paper passage area of the terminal cover (see Figure 1). Carefully slide the air exhaust cover up or down as necessary.

(7) Lift the terminal cover sufficiently to tighten the three air exhaust cover attach screws. **DO NOT** overtighten the screws; damage to the vent slots may occur. Proceed to damper installation (below).

2.3 DAMPER

The damper is attached to the top of the terminal cover in the position shown in Figure 1.

- a. Lift the terminal cover and press against the inside of the left side "false cover" until it unsnaps. Repeat for the right side "false cover" (see Figure 2).
- b. Place the damper in approximate position atop the terminal cover. Manually holding the damper against the terminal cover, lay the terminal cover back on its hinges until the cover rests upside down on the table top.
- c. Move the damper as necessary to align its four screw holes under the two square holes and two round holes in the terminal cover.

- d. Install two screws and the two **small** washers through the two round holes in the terminal cover. *Do not overtighten the screws.*
- e. Place one **large** washer over the right side square hole in the terminal cover. Orient the washer so that the flat on the washer is aligned toward the *inside* of the terminal as shown in Figure 2. The washer must be positioned in this manner to permit replacement of the plastic cover stay over the stay pin. Insert the screw and tighten slightly.
- f. Attach the damper through the left side square hole using the other large washer and remaining screw. Orientation of the left-side large washer is not important.
- g. Rotate the cover back near its normally closed position, lift about 45 degrees, and reconnect the cover stay to its stay pin.

2.4 FINAL STEPS

- a. If applicable, replace the terminal on its accessory stand or table and reattach all fasteners removed in paragraph 2.1.
- b. Reinstall the ribbon and paper and reconnect the power cord and communications cable.

The terminal should now be ready for regular service.

INSTALLATION INSTRUCTIONS OMNI 800* MODEL 820 KSR DATA TERMINAL TERMINAL PAPER BASKET

PART NO. 0999838-0001

1. GENERAL

The Terminal Basket Kit consists of the basket and all necessary hardware to attach the paper basket to the Model 820 KSR terminal.

2. INSTALLATION

1. Lift the cover of Model 820 KSR and disconnect the cover stay (located in right rear of printer) by moving top of stay to right and off of pivot pin attached to cover (see Figure 1). DO NOT let cover open more than 90° to base.
2. Attach ground cable (location: inside right rear of printer) by faston connection on one end and using lockwasher and nut on other end as shown (see Figure 2).
3. Attach stay (which was disconnected in Step 1) to cover and close printer.
4. Insert basket hooks into slotted holes in rear of printer and rotate down into rest position (see Figure 3).

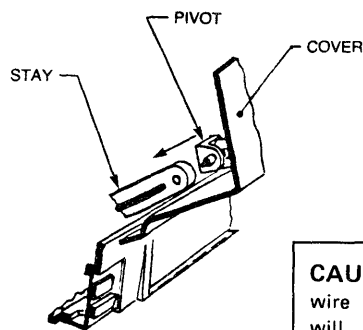

FIGURE 1

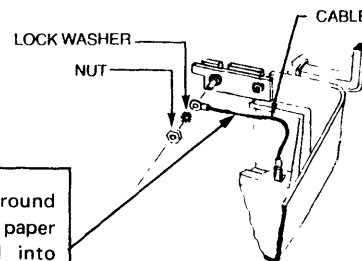

FIGURE 2

CAUTION: If the ground wire is not connected, paper will not properly fold into the basket and erratic terminal operation may occur.

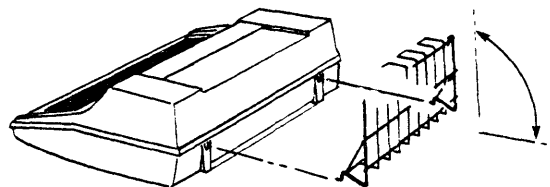

FIGURE 3



TI PUBLICATION 999940-9701
ISSUED 1 OCTOBER 1978
REVISION A

INSTALLATION INSTRUCTIONS *OMNI 800** TERMINAL STAND PAPER BASKET

PART NO. 999839-0001

1. GENERAL

The Terminal Stand Paper Basket kit consists of the paper basket and static ground cable for attachment to the Texas Instruments *Omni 800** printer terminal stand.

2. INSTALLATION

These instructions explain how to attach the paper basket to the terminal stand. Refer to the figure and proceed as follows:

- a. Remove the existing stand screw from stand.
- b. Attach the static ground cable lug to the stand using the existing stand screw removed in step a.
- c. Attach the paper basket by hooking the basket onto the terminal stand pivot pins. Then rotate the basket downward, deflect basket mounting ears inward, and insert the ears into the holes in the terminal stand legs.
- d. Connect the ground cable banana plug into the tube on the basket as shown in the figure.

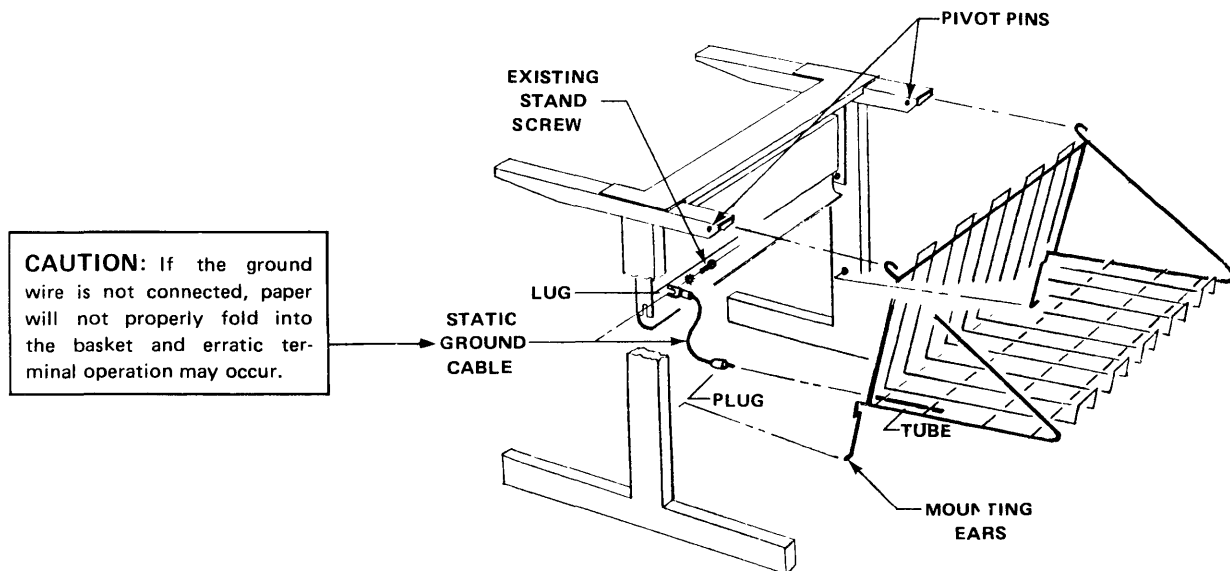

*Omni 800** Terminal Stand Paper Basket

*Trademark of Texas Instruments

TEXAS INSTRUMENTS
INCORPORATED



INSTALLATION INSTRUCTIONS

DEVICE/FORMS CONTROL ROM OPTION KIT

MODEL 820 KSR/RO TERMINALS

MODEL 825 KSR/RO TERMINALS

Factory Installed Kit Part Number 999836-0001

Field Installed Kit Part Number 999836-8001

1.0 GENERAL

The Device/Forms Control Option Kit consists of a TI No. 2207626-0001 pre-programmed ROM which is installed on the main electronic Printed Wiring Board (PWB). These installation instructions explain how to install the kit.

2.0 INSTALLATION

To install the Device/Forms Control Option Kit in the TI Model 820/825 Terminals follow the procedures detailed in steps a. through r. Steps aa. through qq. detail the reassembly procedures. Figure 1 illustrates the physical placement of the ROM.

WARNING

Disconnect Power Cord to prevent possible electrical shock and equipment damage.

2.1 PREPARE THE TERMINAL FOR KIT INSTALLATION AS FOLLOWS:

- a. Unplug the power cord from the power receptacle at the rear of the terminal.
- b. Open the terminal cover by grasping the right and left front corners and gently lifting until the cover will rise no further. A plastic stay at the inside right rear holds the cover open at 45 degrees from horizontal.
- c. While holding the terminal cover with one hand, grasp the top of the plastic stay with the other hand and move the stay to the right until it clears the mounting pin.
- d. Holding the stay clear of the pin, the terminal cover can now be swung back until it rests on the desk or table-top in a fully opened position.
- e. Remove the keyboard bezel by grasping the extreme right and left edges and lifting up.
- f. Manually move the printhead all the way to the right of the platen.
- g. Using a standard slot screwdriver, disengage the four retainer feet at the front of the keyboard plenum from under the top front of the terminal case.
- h. Grasping the right and left front edges of the keyboard plenum, raise the front of the plenum approximately 10 degrees to clear the plenum retainer feet.
- i. While supporting the plenum at approximately 10 degrees, disengage the three rear feet beginning at the right rear.
- j. Lift the plenum clear of the terminal with slight forward motion and set it aside.

- k. Remove the 33 mm (1¼ inch) wide sheet metal ground strap attached to the front left corner of the keyboard PWB by pulling it down and away from the plastic connector.
- l. Loosen the four keyboard PWB keepers along the rear edge of the PWB, using both hands to press in at the base of the keepers while lifting the keyboard slightly.
- m. Lift the tach motor cable, paper drive motor cable, and ribbon drive motor out of the keyboard keeper.
- n. Remove the 25-conductor ribbon cable from its connector on the Keyboard PWB.
- o. Lift the keyboard assembly up from the rear and set the assembly aside.
- p. The main electronic PWB is now accessible for kit installation.
- q. Refer to Figure 1. The Device/Forms Control Option Kit is installed by placing the pre-programmed ROM (TI No. 2207626-0001) in socket XU-12.
- r. The MFG area of the printer configuration label, already affixed inside the rear cover of the terminal should be checked (✓). This will indicate the terminal configuration to other users.

2.2 TO RETURN THE TERMINAL TO OPERATION AFTER KIT INSTALLATION PROCEED IN THE FOLLOWING MANNER:

- aa. Install the keyboard assembly, reinserting the four PWB keepers.

CAUTION

Ensure that all cables are firmly seated or the machine will not operate properly.

- bb. Reconnect the 25-conductor ribbon cable to the Keyboard PWB.
- cc. Replace the tach motor cable, paper drive motor cable, and ribbon drive motor cable back into their holders.
- dd. Reconnect the ground strap to the front left corner of the Keyboard PWB.
- ee. Verify that the printhead is positioned all the way to the right of the platen.
- ff. Verify that the cable from the mechanism to the PWB is routed correctly and secured properly.
- gg. Grasp the edges of the plenum and insert the rear of the plenum between the printhead and cables, ensuring that the plenum fits over the rear fan plenum housing.
- hh. Lift the front of the plenum approximately 10 degrees and insert the three rear tabs into their respective slots inside the terminal.
- ii. Gently push the front of the fan plenum down until it rests on the four front retaining tabs.
- jj. Using a standard slot screwdriver, engage the retaining tabs into their respective catches.
- kk. Replace the keyboard bezel.
- ll. Holding the terminal cover with your left hand and the plastic stay attached to the inside right rear of the cover with your right hand, return the cover to an approximate 45 degree position.

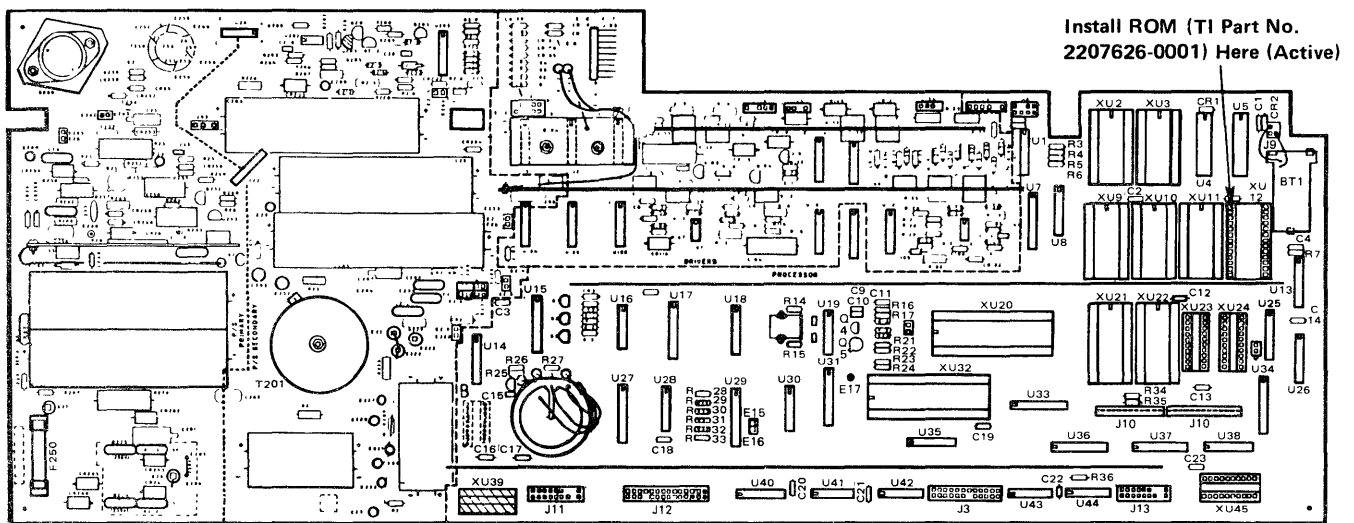

Figure 1. Physical Placement of Installed ROM Kit. (Device/Forms Control Option)

- mm. Supporting the terminal cover with the plastic stay, align the mounting pin with the stay and engage the plastic stay into the mounting pin.
- nn. Close the terminal cover by gently pushing the cover down until the closures snap shut.
- oo. Plug the power cord into the power receptacle at the rear of the Model 820/825.
- pp. Plug the power cord into the primary electrical power receptacle.
- qq. The terminal is now ready for normal operation.

Sales and Service Offices of Texas Instruments are located throughout the United States and in major countries overseas. Contact the Digital Systems Division, Texas Instruments Incorporated, P.O. Box 1444, Houston, Texas 77001, or call (713) 937-2000 for the location of the office nearest to you.



Texas Instruments reserves the right to change its product and service offerings at any time without notice.

**TEXAS INSTRUMENTS
INCORPORATED**



INSTALLATION INSTRUCTIONS

CONFIGURATION PROM KIT OR PROTECTED ABM PROM KIT

MODEL 820 KSR/RO TERMINALS
MODEL 825 KSR/RO TERMINALS
Factory Installed Kit Part Number 2207630-0001
Field Installed Kit Part Number 2207630-8001

1.0 GENERAL

The Configuration PROM Kit consists of two TI No. 2207628 Programmed Configuration PROMs which are installed on the main electronic Printed Wiring Board (PWB); and a TI No. 999931 Configuration PROM Kit label which indicates the PROM Configuration. The label is affixed inside the terminal cover. One of the two configuration PROMs will be active when installed; the other is for use as a spare.

2.0 INSTALLATION

To install the Configuration PROM Kit in the Model 820/825 Terminals follow the procedures detailed in steps a. through r. Steps aa. through rr. detail the reassembly procedures. Figure 1 illustrates the physical placement of the PROMs.

WARNING

Disconnect Power Cord to prevent possible electrical shock and equipment damage.

2.1 PREPARE THE TERMINAL FOR KIT INSTALLATION AS FOLLOWS:

- a. Unplug the power cord from the power receptacle at the rear of the terminal.
- b. Open the terminal cover by grasping the right and left front corners and gently lifting until the cover will rise no further. A plastic stay at the inside right rear holds the cover open at approximately 45 degrees from horizontal.
- c. While holding the terminal cover with one hand, grasp the top of the plastic stay with the other hand and move the stay to the right until it clears the mounting pin.
- d. Holding the stay clear of the pin, the terminal cover can now be swung back until it rests on the desk or table-top in a fully opened position.
- e. Remove the keyboard bezel by grasping the extreme right and left edges and lifting up.
- f. Manually move the printhead all the way to the right of the platen.
- g. Using a standard slot screwdriver, disengage the four retainer feet at the front of the keyboard plenum from under the top front of the terminal case.
- h. Grasping the right and left front edges of the keyboard plenum, raise the front of the plenum approximately 10 degrees to clear the plenum retainer feet.
- i. While supporting the plenum at approximately 10 degrees, disengage the three rear feet beginning at the right rear.

- j. Lift the plenum clear of the terminal with slight forward motion and set it aside.
- k. Remove the 33 mm (1¼ inch) wide sheet metal ground strap attached to the front left corner of the keyboard PWB by pulling it down and away from the plastic connector.
- l. Loosen the four keyboard PWB keepers along the rear edge of the PWB, using both hands to press in at the base of the keepers while lifting the keyboard slightly.
- m. Lift the tach motor cable, paper drive motor cable, and ribbon drive motor out of the keyboard keeper.
- n. Remove the 25-conductor ribbon cable from its connector on the Keyboard PWB.
- o. Lift the keyboard assembly up from the rear and set the assembly aside.
- p. The main electronic PWB is now accessible for kit installation.
- q. Refer to Figure 1. The Configuration PROM Kit is installed by placing the programmed PROM (TI No. 2207628) in socket XU-24 and a spare PROM in socket XU-45.
- r. The label supplied with the Configuration PROM Kit should be affixed to the inside terminal cover, right-hand side. This will indicate the terminal configuration to other users.

2.2 TO RETURN THE TERMINAL TO OPERATION AFTER KIT INSTALLATION PROCEED IN THE FOLLOWING MANNER:

- aa. Install the keyboard assembly, reinserting the four keyboard PWB keepers.

CAUTION

Ensure that all cables are firmly seated or the machine will not operate properly.

- bb. Reconnect the 25-conductor ribbon cable to the Keyboard PWB.
- cc. Replace the tach motor cable, paper drive motor cable, and ribbon drive motor cable back into their holders.
- dd. Reconnect the ground strap to the front left corner of the Keyboard PWB.
- ee. Verify that the printhead is positioned all the way to the right of the platen.
- ff. Verify that the cable from the mechanism to the PWB is routed correctly and secured properly.
- gg. Grasp the edges of the plenum and insert the rear of the plenum between the printhead and cables, ensuring that the plenum fits over the rear fan plenum housing.
- hh. Lift the front of the plenum approximately 10 degrees and insert the three rear tabs into their respective slots inside the terminal.
- ii. Gently push the front of the fan plenum down until it rests on the four front retaining tabs.
- jj. Using a standard slot screwdriver, engage the retaining tabs into their respective catches.
- kk. Replace the keyboard bezel.

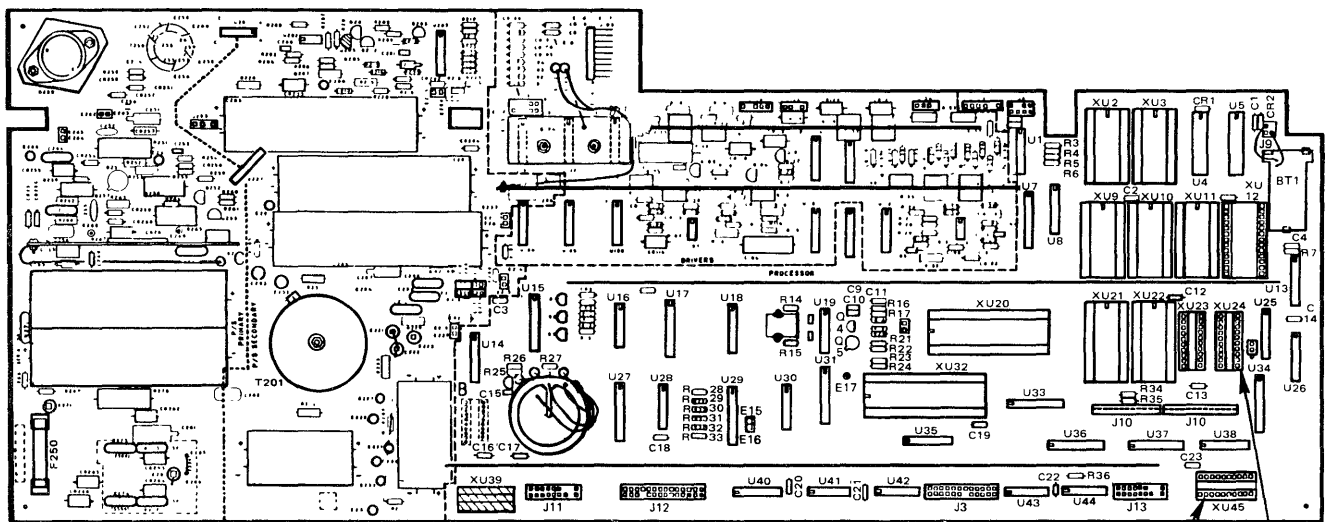

Install PROM (TI Part No. 2207628) Here (Spare)

Install PROM (TI Part No. 2207628) Here (Active)

Figure 1. Physical Placement of Installed PROM's. (Configuration PROM and/or Protected ABM PROM Kit)

- ll. Affix Configuration PROM label (TI No. 999931) to inside right-hand side of terminal cover.
- mm. Holding the terminal cover with your left hand and the plastic stay attached to the inside right rear of the cover with your right hand, return the cover to an approximate 45 degree position.
- nn. Supporting the terminal cover with the plastic stay, align the mounting pin with the stay and engage the plastic stay into the mounting pin.
- oo. Close the terminal cover by gently pushing the cover down until the closures snap shut.
- pp. Plug the power cord into the power receptacle at the rear of the Model 820/825.
- qq. Plug the power cord into the primary electrical power receptacle.
- rr. The terminal is now ready for normal operation.

Sales and Service Offices of Texas Instruments are located throughout the United States and in major countries overseas. Contact the Digital Systems Division, Texas Instruments Incorporated, P.O. Box 1444, Houston, Texas 77001, or call (713) 937-2000 for the location of the office nearest to you.



Texas Instruments reserves the right to change its product and service offerings at any time without notice.

**TEXAS INSTRUMENTS
INCORPORATED**

INSTALLATION INSTRUCTIONS OMNI 800 MODEL 820/825 DATA TERMINALS CURRENT LOOP OPTION

Part No. 0999734-8001

1.0 GENERAL

The current loop option kit contains the PWB assembly, internal and external cables and all the necessary hardware to install the option into the Model 820/825 Terminal. The electrical specifications of the current loop option are:

Transmitter

- Nominal Current: 20 MA DC
- Maximum Current Capability: 100 MA DC
- Maximum Voltage Drop When On (Marking): 1.0 VDC, 20 MA
- Maximum Leakage Current When Off (Spacing): 0.5 MA, 50 VDC
- Maximum Common Mode Voltage: Same as Receiver

Receiver

- Nominal Current: 20 MA DC
- Threshold (Decision) Current: 12 +/- 3.5 MA
- Maximum Voltage Drop: 3.0 VDC at 20 MA
- Maximum Current Rating: 100 MA DC Continuous
- Maximum Common Mode Voltage: 50 VDC, continuous or switched at the configured transmission rate, will not cause errors in received data

2.0 INSTALLATION

1. Unplug power cord.
2. Lift the cover of Model 820/825 and disconnect the cover stay (located in right rear of printer) by moving top of stay to right and off of pivot pin attached to cover (see Figure 1). DO NOT let cover open more than 90° to base.

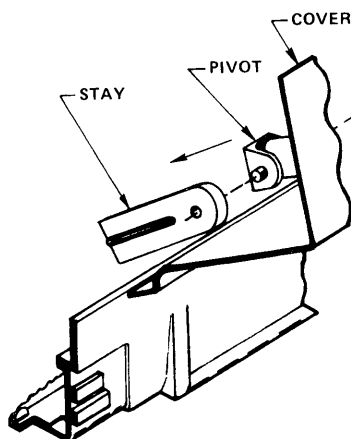

Figure 1. Terminal Cover Stay Detail

3. Remove the keyboard bezel by grasping the extreme right and left edges and lifting up the bezel.
4. Remove the keyboard plenum as follows:
 - a. Manually move the printhead to the right approximately 4 inches to the right of the center of the platen.
 - b. Using a standard slot screwdriver, disengage the four retainer clips at the front of the keyboard plenum.
 - c. Grasping the right and left front edges of the keyboard plenum, raise the front of the plenum approximately 10 degrees to clear the clip latches.
 - d. While supporting the plenum at approximately 10 degrees, disengage the three rear latches beginning with right rear latch.
 - e. Lift the plenum clear of the terminal with slight forward motion and set it aside.
5. Remove keyboard assembly as follows:
 - a. Remove the 33 mm (1¼ inch) wide sheet metal ground strap attached to the front left corner of the keyboard PWB by pulling it down and away from the plastic connector.
 - b. Loosen the four keyboard PWB keepers along the rear edge of the PWB, using both hands to press in at the base of the keepers while lifting the keyboard slightly.
 - c. Lift the tach motor cable, paper drive motor cable, and ribbon drive motor out of their cable retainers on the rear of keepers.
 - d. Remove the 25-conductor ribbon cable from its connector on the Keyboard PWB.
 - e. Snap the keyboard keepers up and away from the keyboard
 - f. Lift the keyboard assembly up from the rear and remove the keyboard PWB out of its plastic support frame.
6. Remove standard EIA cable assembly from terminal as follows:
 - a. Remove mechanism ground wire (and paper basket ground wire if so equipped) from quick disconnect plugs at EIA cable panel mounting screws located inside right rear corner of case. (Refer to Figure 2).
 - b. Using a standard slot screwdriver, remove the two EIA panel mounting screws, lockwashers and quick disconnect lugs. Set hardware aside to be reused for option panel installation.
 - c. Disconnect EIA cable P3 from main PWB J3 and remove cable from retaining clip on front right side of case.
 - d. Remove EIA cable and panel from molded I/O port by pushing down on panel while guiding cable through molded recess.
7. Install current loop option internal cable and panel as follows:
 - a. Insert cable through molded panel opening from rear of terminal.
 - b. Insert panel into molded slot, slide up into case while guiding cable wires past molded recess, and reinstall screws, lockwashers, and quick disconnect lugs removed in 6 b above.

- c. Route cable along lower right side of case. Install P3 end into retaining clip on front right side of case and connect P3 to main PWB J3. (Refer to Figure 3)
 - d. Install mechanism ground wire (and paper basket ground wire if so equipped) onto quick disconnect plugs at EIA cable panel mounting screws.
8. Install current loop option PWB as follows:
- a. Install current loop option PWB into plastic support frame as shown in Figure 3.
 - b. Connect current loop option power cable assembly (flat flex cable) between main PWB J13 and option PWB J30.

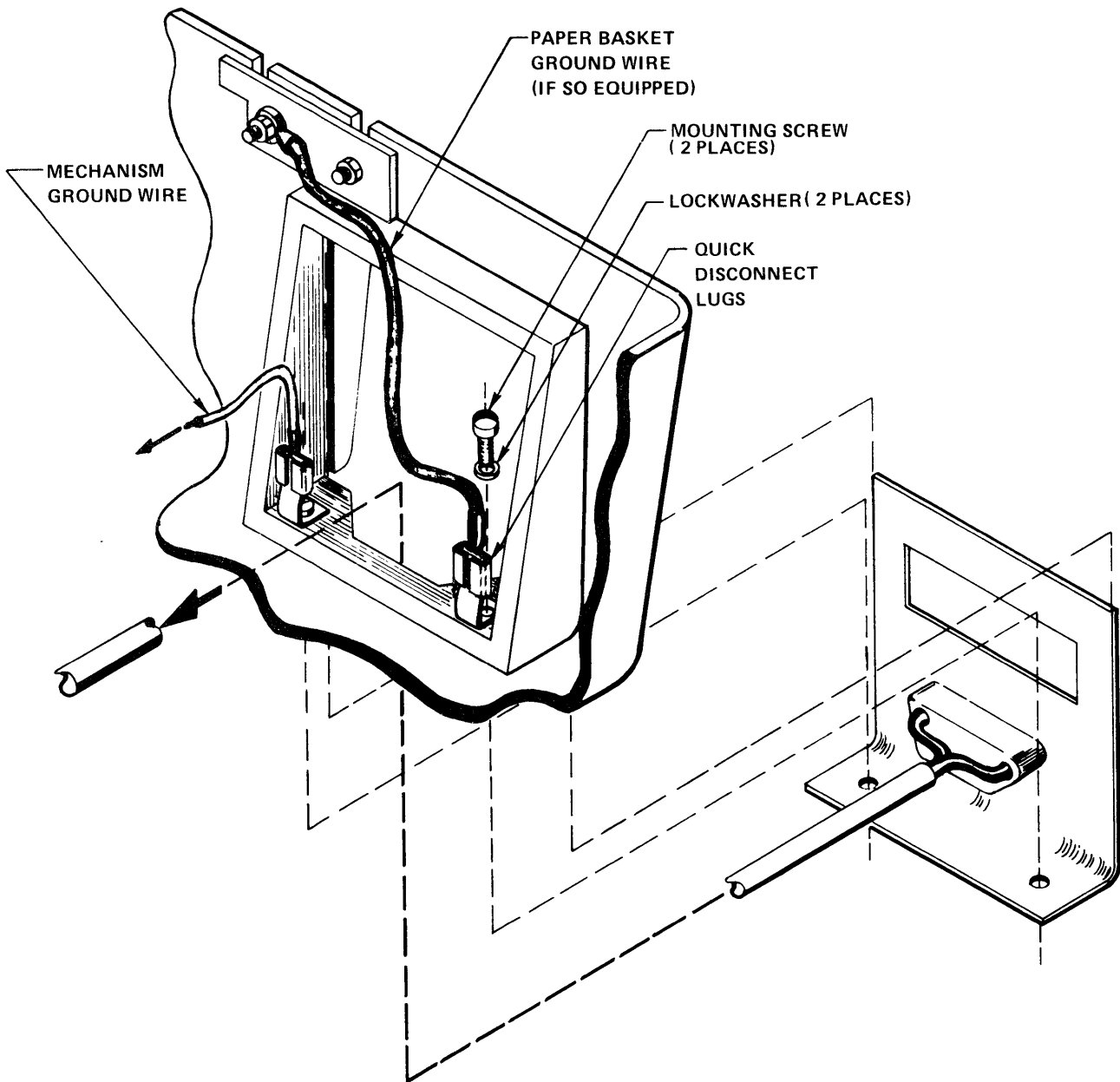

Figure 2. Pictorial Wiring Diagram

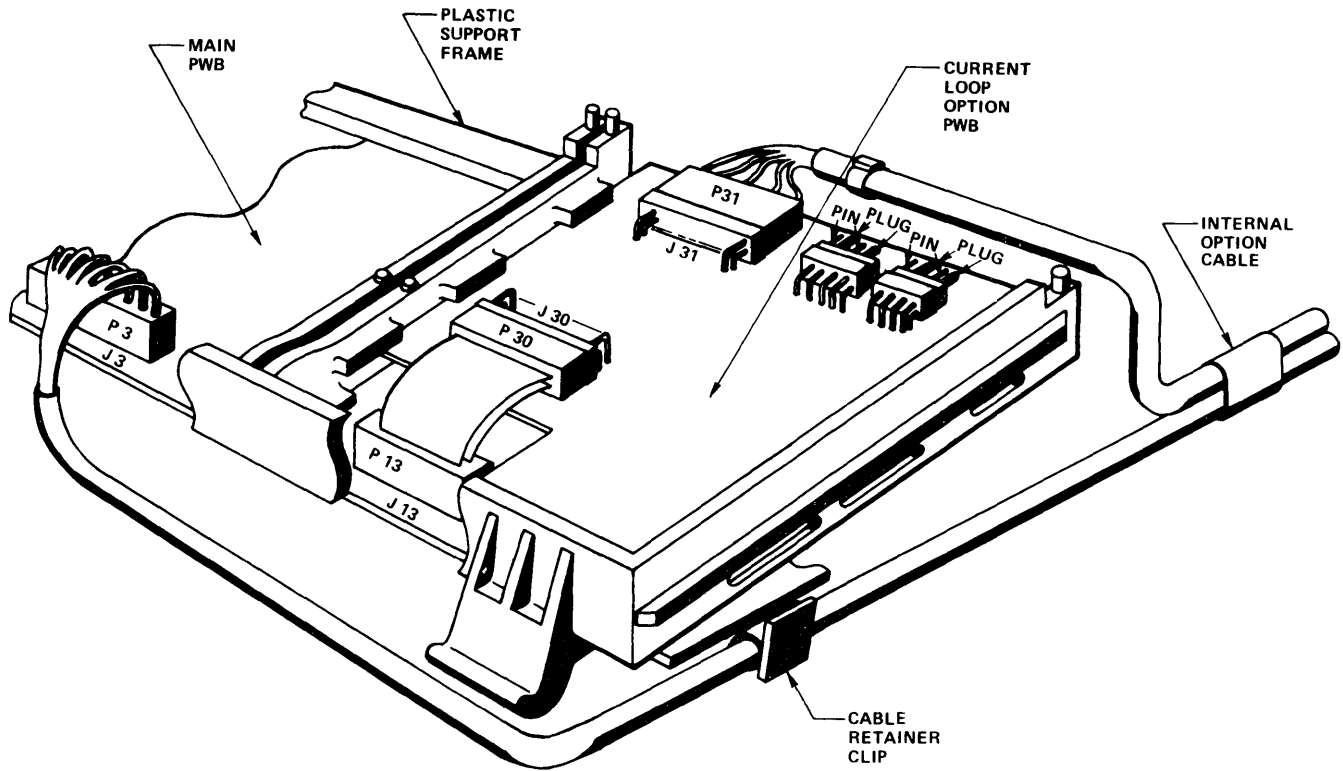

Figure 3. Cable Wiring Detail

9. Replace the keyboard assembly as follows:
 - a. Place the keyboard PWB into plastic support frame and snap the four keepers back in place.
 - b. Replace the tach motor cable, paper drive motor cable, and ribbon drive motor cable back into their cable retainers on the rear of keepers. Check each cable connection to main PWB.
 - c. Route P31 end of current loop option cable with tach motor cable bundle and install P31 to current loop PWB J31.
 - d. Reconnect the 25-conductor ribbon cable to the keyboard PWB.
 - e. Reconnect the ground strap to the front left corner of keyboard PWB.

10. Replace the keyboard plenum as follows:
 - a. Verify that the printhead is positioned approximately 4 inches to the right of the center of the platen.
 - b. Verify that the cable from the mechanism to the PWB is routed correctly and secured properly.
 - c. Grasp the edges of the plenum and insert the rear of the plenum between the printhead and cables, ensuring that the plenum fits over the rear fan plenum housing.

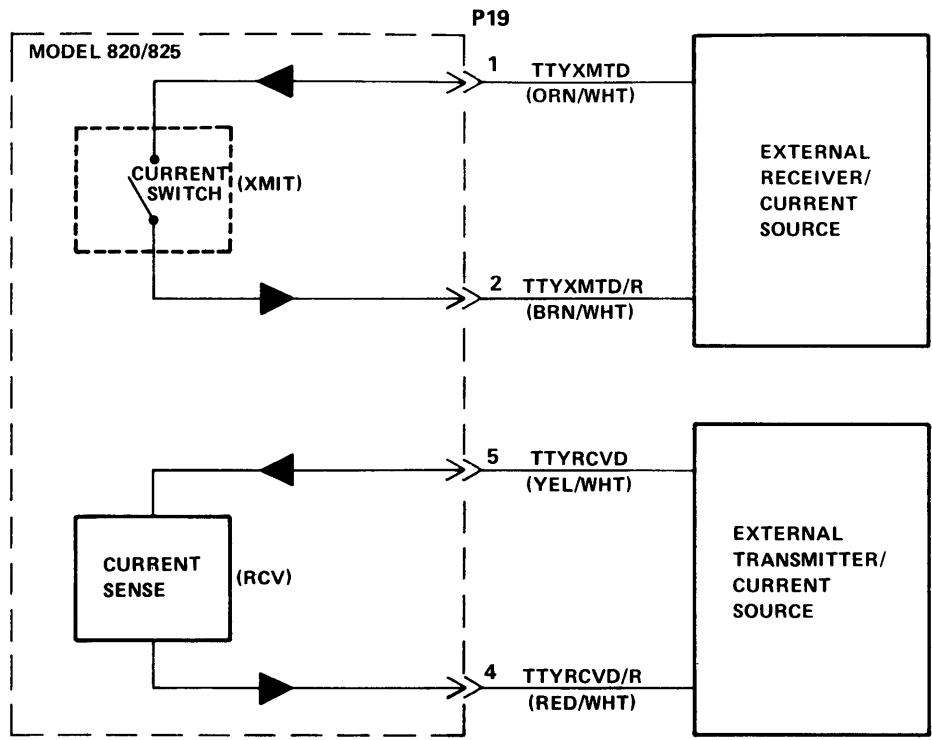

FIGURE 4A. FOUR WIRE FULL DUPLEX

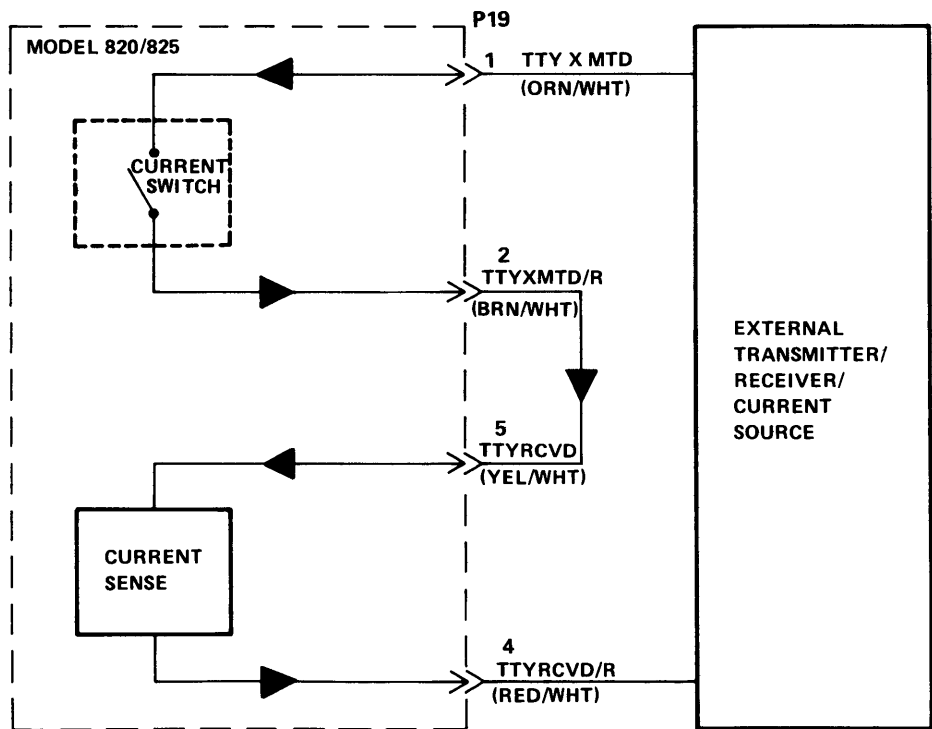

FIGURE 4B. TWO WIRE HALF DUPLEX

Figure 4. Model 820 Current Loop Configurations

- d. Lift the front of the plenum approximately 10 degrees and insert the three rear tabs into their respective slots inside the terminal.
 - e. Gently push the front of the plenum down until it rests on the four front retaining tabs.
 - f. Using a standard slot screwdriver, engage the retaining tabs into their respective latches.
 - g. Replace the keyboard bezel.
11. Install external cable and shorting plug as follows:
- a. An external shorting plug completes the circuit between the current loop PWB and the terminal electronics PWB. For current loop operation the shorting plug must be installed to the 25-pin connector located on the rear of the terminal.
 - b. A 6-foot cable is provided to connect the Model 820 to the communication line. The cable consists of a 9 pin connector for connection at the rear of the terminal and four spade lugs at the other end of the cable.
 - c. Table 1 shows the interface cable pin assignments.
 - d. The four spade lugs should be connected to the external communication line as described in Figure 4. This figure shows the connection for the four wire full duplex or the 2 wire "half duplex" configurations.
12. a. Mark CTY communications option on configuration label located inside terminal cover rear wall.

Table 1. Standard dc-Current Loop Interface Cable Pin Assignments (Cable Part No. 994403)

P19 Connector To Model 820/825	Cable Termination	Function
P19-1	TTYXMTD (Orn/White Wire)	Transmitted Data Current Input
P19-2	TTYXMTD/R (Brn/White Wire)	Transmitted Data Current Output
P19-5	TTYRCVD (Yel/White Wire)	Received Data Current Input
P19-4	TTYRCVD/R (Red/White Wire)	Received Data Current Output

APPENDIX F

GLOSSARY OF MODEL 820 KSR AND RO SIGNALS

A0 through A15	Address Bus
/A10	Inverted Address Line 10
ACC1	Acceleration 1 (Carriage Motor)
ACC2	Acceleration 2 (Carriage Motor)
AC COMMON	AC Neutral (Input Power)
AC LINE	AC Line (Input Power)
BA	Transmitted Data (EIA RS-232C)
BA0 - BA7	Buffered Address lines 0 - 7
BAUDCLK	Baud rate clock
BD0 - BD7	Buffered Data Bus
/BDIRECT	Buffered carriage motor direction indicator
BELL	Bell enable
BIE2	Buffered Interrupt Enable 2
/BIORQ	Buffered I/O Request Cycle
/BM1	Buffered Op Code Fetch Cycle
BOSC	Buffered clock oscillator
/BRD	Buffered Memory Read Cycle
/BSENSOR	Buffered sensor pulses
/BWR	Buffered Memory Write Cycle
BX1	Buffered X1
/BX2	Buffered and inverted X2
CA	Request to Send (EIA RS-232C)
/CARDET	Data Carrier Detect (Received Line Signal Detector)
CC	Data Set Ready (EIA RS-232C)
CD	Data Terminal Ready (EIA RS-232C)
CE	Ring Indicator (EIA RS-232C)
CH	Data Signal Rate Selector (EIA RS-232C)
CHASSIS GND #1 - #3	Chassis ground networks
/CLK	System Clock
CLK/2	System clock ÷ 2
CLKMOS	System clock
CLRDOTS	Dot latch clear
CMFWD	Forward movement command
/CMOSRAMSEL	CMOS RAM Select
CMTRA	Carriage motor power
CMTRB	Carriage motor power
COCHR	Compressed print indicator
/CTS	Clear to Send
D0 - D7	Data Bus
DIRECT	Carriage motor direction indicator
DFWT	Forward tachometer direction
DOT1 - DOT8	Solenoid logic signals (printhead)
/DSR	Data Set Ready
DTACH	Sensor tachometer pulses
/DTR	Data Terminal Ready
/DX	Tachometer state variable
/DY	Tachometer state variable

FAN+	Fan supply
FAN-	Fan supply
FWD	Carriage motor forward
/GO	Wait state variable
IE1	Interrupt enable 1
IE2	Interrupt enable 2
IE3	Interrupt enable 3
/INT	Interrupt request line
/IO0	I/O Device 0 (output latch) select
/IO1	I/O Device 1 (carriage/paper motor latch) select
/IO2	I/O Device 2 (keyboard row latch) select
/IO3	I/O Device 3 (ribbon/row latch) select
/IO4	I/O Device 4 (dot latch) select
/IO6	I/O Device 6 (keyboard buffer) select
/IO7	I/O Device 7 (misc. buffer) select
/IORQ	I/O Request Cycle
KBD0 - KDB7	Keyboard data bus
/LCTS	Clear to Send
/LDCCD	Data Carrier Detect
LOOPBACK	Loopback select
LRXD	Received data
LTXD	Transmitted data
/MREQ	Memory Request cycle
/M1	Op Code Fetch cycle
OSC	Clock oscillator
P0A - P0D	Paper phase A, B, C, D (logic)
/PAPOUT	Paper out signal (logic)
PAPOUTSW	Paper out switch signal
PDMCC	Paper drive motor current control
PDRV	Ribbon drive
PPHSA - PPHSD	Paper phase A, B, C, D (power)
/PROM 1 SEL	PROM 1 select (Option PROM)
/PROM 2 SEL	PROM 2 select (Option PROM)
PWRGOOD	Power Good
/RAM 1 SEL	RAM 1 Select
/RAM 2 SEL	RAM 2 Select
/RD	Memory read cycle
/RI	Ring indicator
/RIBREV	Ribbon reverse (logic)
RIBREVS	Ribbon reverse (power)
/ROM 1 SEL	ROM 1 (Operating System) select
/ROM 2 SEL	ROM 2 (Operating System) select
/ROM 3 SEL	ROM 3 (Dot ROM) Select
/ROM 4 SEL	ROM 4 (DFC option ROM) select
/RTS	Request to Send
RXD	Received data

R0 - R11	Keyboard row select lines
R0A - R0D	Ribbon motor phases A through D (logic)
/RATE	Data Signal Rate Selector
RDRV	Ribbon drive
/READ OPTION	Option board data direction control
REV	Carriage Motor reverse
RPHSA - RPHSD	Ribbon motor phases A through D (power)
SCA	Secondary Request to Send (EIA RS-232C)
/SCARDET	Secondary Data Carrier Detect
SCF	Secondary line signal detector, Secondary Data Carrier Detect (EIA RS-232C)
SENSOR	Sensor pulses
SF1 - SF8	Solenoid drive signals (printhead)
SHIELD	Ground Shield
STPTFG	System test print flag
/STPWRGOOD	System test power good indicator
/SRTS	Secondary Request to Send
/SYSTSTINT	System test (non-maskable) interrupt
T0A1 - T0A2	Tachometer pulses (normal)
T0B1 - T0B2	Tachometer pulses (compressed)
TXD	Transmitted data
/WAIT	Wait (CPU)
WAIT GEN	Wait generator
/WR	Memory write cycle
X1	Spare outputs
X2	Spare outputs
Z1	Spare input
+5 V	+5 Volt Supply
+5 VDVR	+5 Volt Drivers
+5 VSW	+5 Volt Switched
+5.1 VCR	+5.1 Volt Reference
+12 V	+12 Volt Supply
-12 V	-12 Volt Supply
+33 V	+33 Volt Supply
+33 VHD	+33 Volt Printhead
+33 VMTR	+33 Volt Motor
+33 VMTRFZD	+33 Volt Motor, Fused
162 VDC	+162 Volts DC
325 VDC	+325 Volts DC

APPENDIX G

RECOMMENDED DATA SET OPTIONS AND CABLING INFORMATION

Table G-1. Recommended Data Set Options

103J	
Modem Option	Recommended Setting
Receive space disconnect	Either — T or U
Send space disconnect	Either — V or Y
Loss of carrier disconnect	Either — S or R
CC Indication	Early — ZD
CB and CF indications	Common — A
CC indication for analog loop	On — ZF
Automatic answer	Yes — ZH
Failsafe state of CN circuit	Off — J
Common ringer	Either — ZB or ZA
Common grounds	Yes — Q
Tip ring make busy	No — E

202S	
Modem Option	Recommended Setting
Soft turnoff and squelch intervals	Soft turnoff = 24 ms (R) Squelch = 156 ms (R)
Fast carrier detect	Out — N
Clear-to-send interval	180 ms — G
Auto answer	In — B
Local copy primary channel	Out — ZB
Condition of CC (DSR) in analog loop	On — YI
Transmit only	Out — YH
Echo suppression enable	Out — YR
Carrier control turnaround	In — YS
Early CC (DSR) indication	Out — YV
Reverse channel	Either — ZC or ZD
Local copy on reverse channel	Out — ZF
Grounding option	Signal ground to frame — ZG

212A	
Modem Option	Recommended Setting
Tip ring make busy	Out — E
CC indication for analog loop	On — ZF
CN circuit	Out — YF
Transmitter timing	Internal — YC
1200 baud operation	Async/start-stop — YG
Character length	10-bit — YS
Receiver respond to digital loop	Off — YL
Loss of carrier disconnect	In — S
Receive space disconnect	In — V
CB and CF indications	Common — A
Send space disconnect	In — T
Automatic answer	In — ZH
Answer mode indication, CE	Off — W
Speed mode	Dual — YP
Interface speed indication, CI	In — YQ
Signal ground to frame connection	In — A

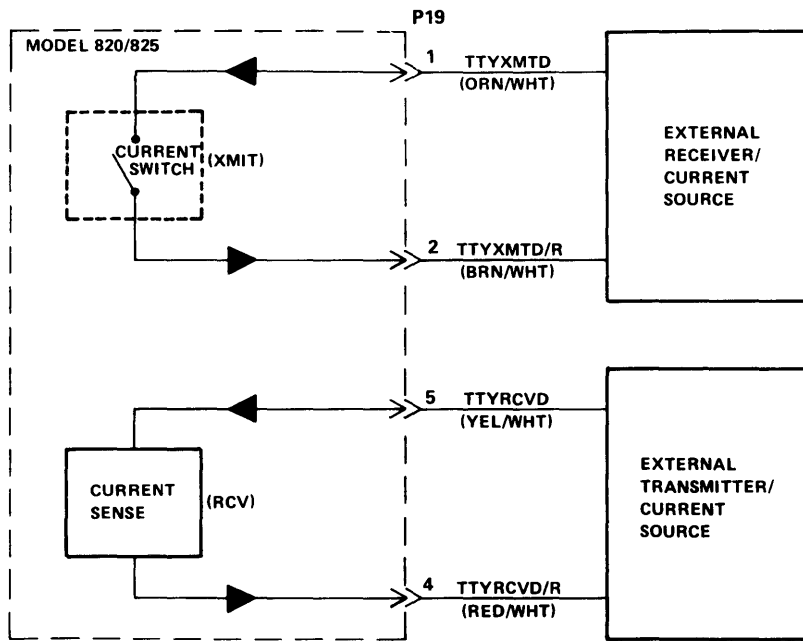

FIGURE 4A. FOUR WIRE FULL DUPLEX

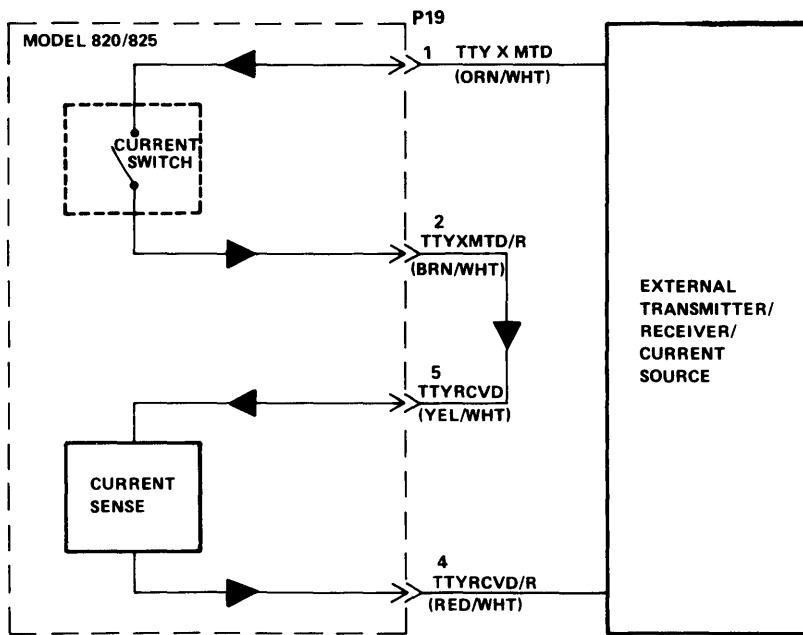
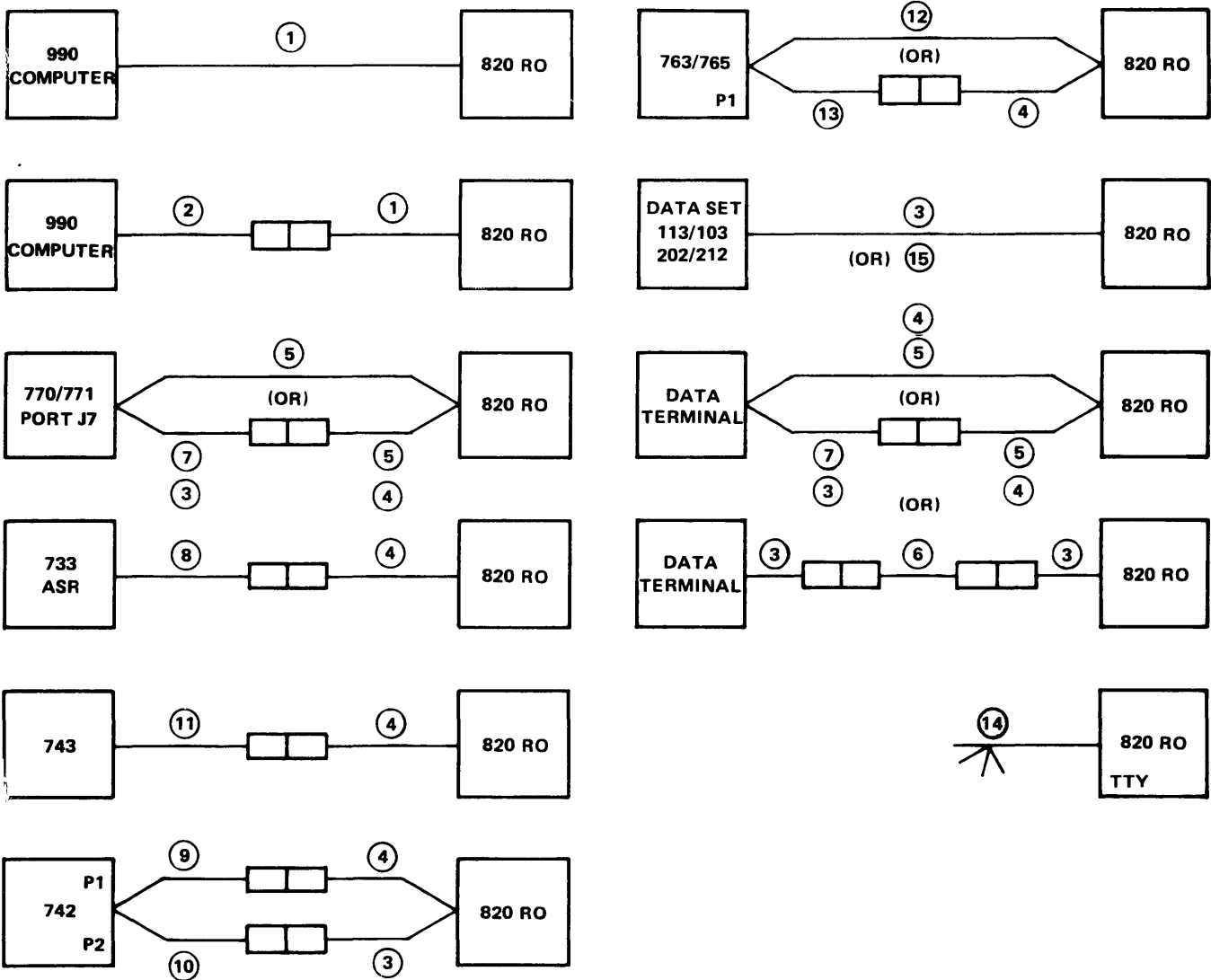

FIGURE 4B. TWO WIRE HALF DUPLEX

Figure G-1. Model 820 Current Loop Interface Configurations

Table G-2. Summary of Cables



Item	Part Number	Description	820 RO Connector Type	Device Connector Type	Length	
					Meters	Feet
1	2262093-0001	990 TTY/EIA To 820 Cable	25 Pin Male	25 Pin Male	9.1	30
2	2262094-0001	990 Extension - 820 Cable	25 Pin Male	25 Pin Female	1.8	6
3	993205-0001	113A/103/202/212 Data Set	25 Pin Male	25 Pin Male	1.8	6
4	993210-0001	Data Terminal Cable	25 Pin Male	25 Pin Female	1.8	6
5	993239-0001	770 Data Terminal Cable	25 Pin Male	25 Pin Male	1.8	6
6	2263351-0001	Terminal Adapter Cable	25 Pin Female	25 Pin Female	1.8	6
7	993211-0001	EIA Extension Cable (25 wires)	25 Pin Male	25 Pin Female	1.8	6
8	959372-0002	733 EIA Cable	25 Pin Male	25 Pin Edge	1.8	6
9	969626-0001	742 EIA Cable	25 Pin Male	10 Pin Dual Edge Connector		
10	973265-0001	742 Auxiliary Cable	25 Pin Female	15 Pin Dual Edge Connector	1.8	6
11	983848-0001	743 EIA Cable	25 Pin Male	15 Pin Female	1.8	6
12	2263350-0001	763/765 Data Terminal Cable	25 Pin Male	15 Pin Female	1.8	6
13	2200051-0001	763/765 Data Set Cable	25 Pin Male	15 Pin Female	1.8	6
14	994403-0001	TTY Current Loop Cable	—	—	1.8	6
15	2207634-0001	Asynch/Synch EIA Cable	25 Pin Male	25 Pin Male	1.8	6

Table G-3. 113A/103, 202/212 Data Set Cable (TI Part No. 993205-0001)

820 Pin P6-P7 (Male)	Data Set Pin (Male)	RS-232-C Circuit	Function
1	1	AA	Protective Ground
2	2	BA	Transmitted Data
3	3	BB	Received Data
4	4	CA	Request to Send
5	5	CB	Clear to Send
6	6	CC	Data Set Ready
7	7	AB	Signal Ground
8	8	CF	Received Line Signal Detector
11	11	SCA	Secondary Request to Send (Reverse Channel Transmit)
12	12	SCF	Secondary Received Line Signal Detector (Reverse Channel Receive)
20	20	CD	Data Terminal Ready
22	22	CE	Ring Indicator

Table G-4. Data Terminal Cable (TI Part No. 0993210-0001)

Reference:	Pin	RS-232-C Circuit	Function
(Either End)	1	AA	Protective Ground
	2	BA	Transmitted Data
	3	BB	Received Data
	4	CA	Request to Send
	5	CB	Clear to Send
	6	CC	Data Set Ready
	7	AB	Signal Ground
	8	CF	Data Carrier Detect
	11	SCA	Reverse Channel Transmit
	12	SCF	Reverse Channel Receive
	15	DB	Transmission Signal Element Timing
	17	DD	Receive Signal Element Timing
	20	CD	Data Terminal Ready
	24	AUXLIO	Auxiliary Input/Output Control

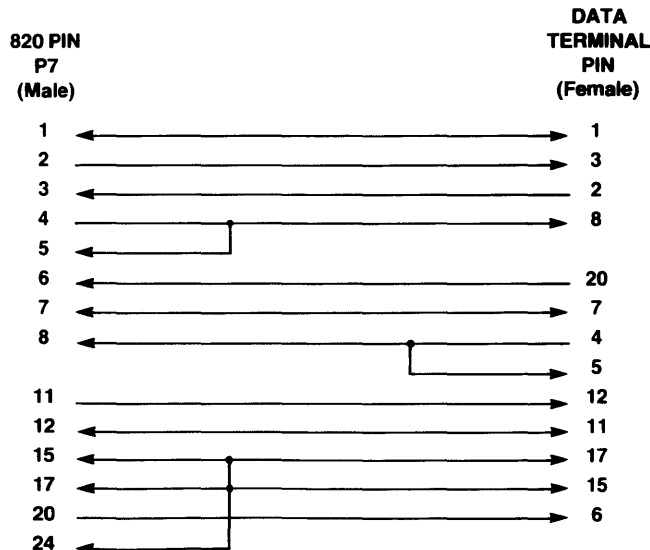

**Table G-5. 770 Data Terminal Cable
(TI Part Number 993239-0001)**

Reference:	Pin	RS-232-C Circuit	Function
(Either End)	1	AA	Protective Ground
	2	BA	Transmitted Data
	3	BB	Received Data
	4	CA	Request to Send
	5	CB	Clear to Send
	6	CC	Data Set Ready
	7	AB	Signal Ground
	8	CF	Data Carrier Detect
	11	SCA	Reverse Channel Transmit
	12	SCF	Reverse Channel Receive
	15	DB	Transmission Signal Element Timing
	17	DD	Receive Signal Element Timing
	20	CD	Data Terminal Ready
	24	AUXLIO	Auxiliary Input/Output Control

**Table G-6. Terminal Adapter Cable Pin Assignments
(TI Part No. 2263351-0001)**

Reference:	Pin	EIA RS-232-C Circuit	Function
(Either End)	1	AA	Protective Ground
	2	BA	Transmitted Data
	3	BB	Received Data
	4	CA	Request to Send
	5	CB	Clear to Send
	6	CC	Data Set Ready
	7	AB	Signal Ground
	8	CF	Data Carrier Detect
	11	SCA	Reverse Channel Transmit
	12	SCF	Reverse Channel Receive
	15	DB	Transmission Signal Element Timing
	17	DD	Receive Signal Element Timing
	20	CD	Data Terminal Ready
	24	AUXLIO	Auxiliary Input/Output Control

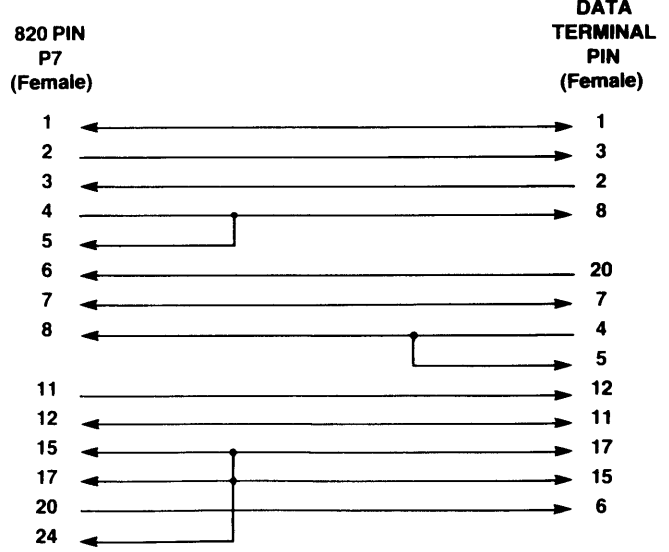
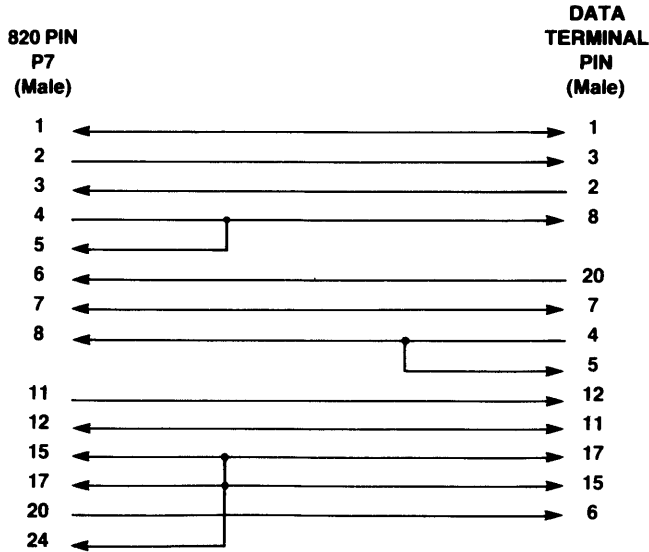

Table G-7. 733 ASR Terminal Cable, 1200 Baud
(TI Part Number 959372-0002)

820 Pin P13	ASR Pin P1	RS-232-C Circuit	Function
1	A	AA	Protective Ground
2	H	BA	Transmitted Data
3	10	BB	Received Data
4	C	CA	Request to Send
5	8	CB	Clear to Send
6	9	CC	Data Set Ready
7	7	AB	Signal Ground
8	K	CF	Received Line Signal Detector
20	6	CD	Data Terminal Ready

Table G-10. 743 Terminal Cable
(TI Part Number 983848-0001)

820 Pin P2	743 Pin P1	RS-232-C Circuit	Function
1	9	AA	Protective Ground
2	13	BA	Transmitted Data
3	12	BB	Received Data
4	10	CA	Request to Send
7	1	AB	Signal Ground
8	11	CF	Received Line Signal Detector
20	15	CD	Data Terminal Ready

Table G-8. 742 Terminal Cable
(TI Part Number 969626-0001)

820 Pin P13	742 P1	RS-232-C Circuit	Function
1	A	AA	Protective Ground
2	H	BA	Transmitted Data
3	10	BB	Received Data
4	F	CA	Request to Send
5	8	CB	Clear to Send
6	9	CC	Data Set Ready
7	7	AB	Signal Ground
8	K	CF	Received Line Signal Detector
11	5	SCA	Secondary Request to Send
12	4	SCF	Secondary Received Line Signal Detector
20	6	CD	Data Terminal Ready
22	J	CE	Ring Indicator

Table G-11. 763/765 Data Terminal Cable Pin Assignments
(TI Part No. 2263350-0001)

763/765 Terminal Connector (P1)	820 Terminal Connector	Function	763/765 Circuit	
			EIA	C.C.I.T.T.
-1	-1	PG	AA	101
-2	-11	CTS	CB	106
-3	-2	RCV	BB	104
-4	-4 and -5	DCD	CF	109
-8	-6	DTR	CD	108.2
-9	-20 and -8	DSR/CCT	CC	107
-14	-3	XMT	BA	103
-15	-7	SG	AB	102

Table G-9. 742 Auxiliary Cable
(TI Part Number 973265-0001)

820 Pin P13	742 Pin P2	RS-232-C Circuit	Function
3	11	BB	Received Data
4		CA	Request to Send
5		CB	Clear to Send
6		CC	Data Set Ready
7	1	AB	Signal Ground
8		CF	Received Line Signal Detector
11	12	SCA	Secondary Request to Send
12	13	SCF	Secondary Received Line Signal Detector
20		CD	Data Terminal Ready

Table G-12. TTY Current Loop Interface Cable P/N 994403-0001

820 Pin	Retainer Clip	Function
1	E2	TTY Transmitted Data
2	E1	TTY Transmitted Data Return
4	E4	TTY Received Data Return
5	E3	TTY Received Data

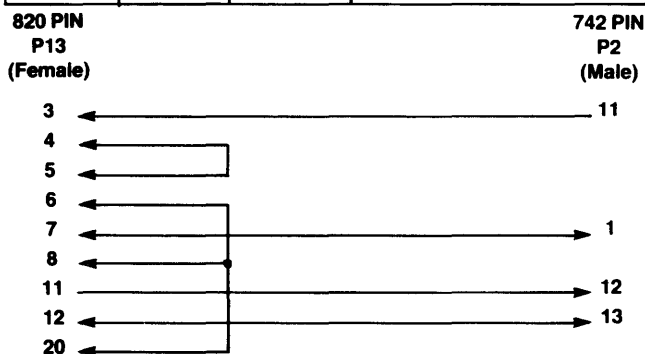

**Table G-13. Asynch/Synch EIA Cable
(TI Part Number 2207634-0001)**

820 Pin (Male)	Data Set Pin (Male)	RS-232-C Circuit	Function
1	1	AA	Protective Ground
2	2	BA	Transmitted Data
3	3	BB	Received Data
4	4	CA	Request to Send
5	5	CB	Clear to Send
6	6	CC	Data Set Ready
7	7	AB	Signal Ground
8	8	CF	Received Line Signal Detector
11	11	SCA	Secondary Request to Send
12	12	SCF	Secondary Re- ceived Line Signal Detector
15	15	DB	Transmission Sig- nal Element Timing
17	17	DD	Receiver Signal Element Timing
20	20	CD	Data Terminal Ready
22	22	CE	Ring Indicator
23	23	CH	Data Signal Rate Selector (DTE)

INDEX

A

Accessories 1-4, Appendix C
Acoustic Coupler Transmit Level
 Adjustments 5-6
Alternate Character Barberpole Test 5-5
Alternate Character Set Keyboard —
 ASCII/APL (Model 820 KSR Only) 3-23
Assemblies Removal And Replacement 5-12
Audible Tone 3-9
Audible Tone Test 5-3
Automatic New Line 3-11

B

Barberpole Test 5-3
Blocking Oscillator Circuit 4-4

C

Carriage Jam Detection 4-23
Character Printing 4-23
Character Set Dot Matrix Appendix A
Character Set and Font 3-9
Chassis Ground 5-10
Code Generating Keys 3-7
Column Data 4-15
Communications Interface 3-13, 4-18
Communications Interface Cable Connection .. 2-20
Communications Test (KSR Only) 5-5
Compressed Print 3-20
CONFIGURE/OPERATE Switch
 (Model 820 KSR Only) 3-8
Configuration Parameter Entry 2-18
 Initiate Configuration 2-18
 Review Current Configuration 2-18
 Enable Mutually Exclusive Parameters 2-19
 Enable ON/OFF Parameters 2-19
 Disable ON/OFF Parameters 2-19
 Program the ABM, and ENTER Key 2-19
Configuration Errors 2-20
 Terminate Configuration 2-20
Configuration Parameter Selection 2-9
Configuration Set Selection (01-09) 2-11
Communication Mode (11-16) 2-11
Communications Rate 2-11
 Parity (31-39) 2-12
 Line Control (61-67) 2-13
 Transmission Control (71-72) 2-14
 Terminal Control (81-89, 91-93) 2-15
 Programmable Parameters
 (ABM, ENTER) 2-16
Configuration Report 2-17, 5-6
 Local Mode or Standby Mode (KSR) 2-17

 Local Mode or Standby Mode (RO) 2-17
 Line Mode (DFC option only) KSR And RO) .. 2-18
Console Operation 3-19
Control Characters 3-11
Control Panel 3-3
Current-Loop Interface 3-25
Current-Loop (TTY) Interface (Optional) 4-19

D

Data Buffering and Printer Throughput 3-12
Data Set Applications 5-11
Data Set Options Appendix G
Device/Forms Control (DFC) 3-20

E

EIA Plug 5-5
End-Of-Line Alarm 3-9

F

Features and Specifications 1-2
Format Parameters 3-10
Full-Duplex Operation 3-16

G

Glossary of Model 825 KSR
 and RO Signals Appendix F
Grounding Requirements 5-10

H

Half Duplex (without Reverse Channel)
Operation 3-17
Half Duplex (with Reverse Channel) Operation .. 3-18
Hard-Wired (Console) Applications 5-11
HERE IS Key 3-7

I

Identification 1-4
Indicator Test 5-2
Input Voltage Selection And Rectification 4-3
Installation Of Optional Kits Appendix E
Interface Signals 3-13, 4-18
Interface Signal Levels 3-15
Introduction 1-1

J

K

Keyboard Interface 4-17
Keyboard Matrix 4-15
Keyboard/Switch Scan 4-15

INDEX (Continued)

KSR Keyboard	4-15	Printer Ribbon And Paper Recommendations	Appendix D
L		Printhead Carriage Drive	4-22
LINE Mode	3-16	Printhead Positioning	4-22
LINE/●/Switch	3-3	Programmable Read-Only-Memory (Optional)	4-12
LINE RDY and CARR RCV Indicators	3-3		
Local Mode	3-15		
M			
Maintenance Tests	5-3	Q	
Mechanism Failure Detection	3-13	R	
Memory Control Logic	4-12	RAM Test	5-3
N		Random Access Memory	4-12
No-LTA Operation (Half-Duplex Modes 11 and 12)	3-19	Read-Only Memory	4-11
Nonvolatile Memory	4-11	Reference Sensing Circuit	4-5
Nonvolatile Memory Test	5-3	Removal and Replacement of Terminal Cover	5-12
Numeric Keypad (Model 820 KSR Only)	3-25	Removal and Replacement of the Keyboard Plenum	5-13
Numeric Keypad Option	3-8	Removal and Replacement of the Fan Assembly	5-13
O		Removal and Replacement of the Keyboard Assembly (Keyboard PWB)	5-14
Operational Checkout and Printhead Adjustment	2-6	Removal and Replacement of the Logic PWB (Main Electronic PWB)	5-15
Model 820 KSR	2-6	Removal and Replacement of Logic PWB Battery	5-16
Model 820 RO	2-7	Removal and Replacement of PWB Fuse 250V, 3A)	5-17
Operator Interface	4-14	Removal and Replacement of Paper Drive Motor	5-17
Operator's Keypad (Model 820 RO Only)	3-7	Removal and Replacement of the Tractor Assembly	5-18
Operator's Panel	3-2	Removal and Replacement of the Printhead	5-19
Operator's Reference Cards	3-26	Printhead Ribbon Guide Adjustment	5-20
Options	1-3, 3-20, Appendix C	Removal and Replacement of the Ribbon Drive Subassembly	5-20
P		Removal of the Carriage Motor and Mechanism (or Wire rope or Mechanism)	5-21
Paper Drive Subsystem	4-20	Ribbon Drive Subsystem	4-20
Paper Loading	2-3	Ribbon Installation	2-4
Paper Motor Driver Circuit	4-20	Ribbon Motor Direction	4-20
Paper-Out Condition	3-12	Ribbon Motor Drive	4-20
Paper-Out Detection	4-21	RO Keyboard	4-15
Power Cord Connection	2-2	ROM Identification Report	5-6
Power-Good Circuit	4-5	Troubleshooting	5-7
Power-On Procedure	2-5	ROM Test	5-3
Power-Off Procedure	2-6	Run-In Test	5-5
Power Supply	4-2		
Power-Up Diagnostic Tests	5-2		
Preventive Maintenance	5-1		
Printable Characters	3-9		
Printer	3-9		
Printer Operation	3-9		

INDEX (Concluded)

S

Secondary Filtering And Regulation	
Circuits	4-5
Self-Tests	5-2
Self-Test Procedure for Model 820 KSR	
and RO Terminals	2-8
Serial I/O Controller	4-19
Setting The Top-Of-Form	3-12
Method 1 (Using ↑ and ↓)	3-12
Method 2 (Using ESC)	3-13
Signal Ground	5-11
Signal Level Conversion	4-19
Soft-Start Circuit	4-4
Space Requirement	2-1
Special Function Keys	3-6
Standby Mode	3-15
System Clock	4-14
System Requirements	5-11

T

Terminal Controller Memory	4-11
----------------------------	------

Terminal Controller Subsystem	4-5
Terminal Status Display (TSD)	3-4
Terminal Status Displays and Indicators	4-17
Typewriter Keyboard	
(Model 820 KSR Only)	3-7

U

User-Defined Configuration Sets	3-23
USASCII/APL Codes	Appendix B

V

VIEW/OFF Switch	
(Model 820 KSR Only)	3-3

WXY

Z

Z-80A CPU Timing	4-8
Z-80A CTC Counter Timer Circuit	4-14
Z-80A Microprocessor	4-6

USER'S RESPONSE SHEET

Manual Title: 820 KSR/RO Terminal Maintenance Manual

Manual No. 2206552-9701

Manual Date: 15 September 1979 Date of This Letter: _____

User's Name: _____ Telephone: _____

Company: _____ Office/Department: _____

Street Address: _____

City/State/Zip Code: _____

Please list any discrepancy found in this manual by page, paragraph, figure, or table number in the following space. If there are any other suggestions that you wish to make, feel free to include them. Thank you.

CUT ALONG LINE

Location in Manual	Comment/Suggestion
_____	_____
_____	_____
_____	_____
_____	_____
_____	_____
_____	_____
_____	_____
_____	_____
_____	_____
_____	_____
_____	_____
_____	_____
_____	_____

NO POSTAGE NECESSARY IF MAILED IN U.S.A.
FOLD ON TWO LINES (LOCATED ON REVERSE SIDE), STAPLE AND MAIL

FOLD



NO POSTAGE
NECESSARY
IF MAILED
IN THE
UNITED STATES

BUSINESS REPLY MAIL
FIRST CLASS PERMIT NO 6189 HOUSTON, TX

POSTAGE WILL BE PAID BY ADDRESSEE

**Texas Instruments Incorporated
Attn: Technical Publications M/S 7761
P.O. Box 1444
Houston, TX 77001**

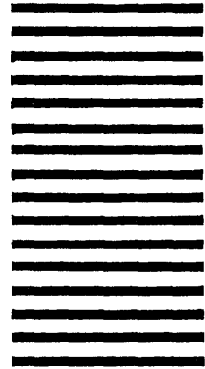

FOLD

Sales and Service Offices of Texas Instruments are located throughout the United States and in major countries overseas. Contact the Digital Systems Division, Texas Instruments Incorporated, P.O. Box 1444, Houston, Texas 77001, or call (713) 937-2000 for the location of the office nearest to you.



Texas Instruments reserves the right to change its product and service offerings at any time without notice.

**TEXAS INSTRUMENTS
INCORPORATED**